

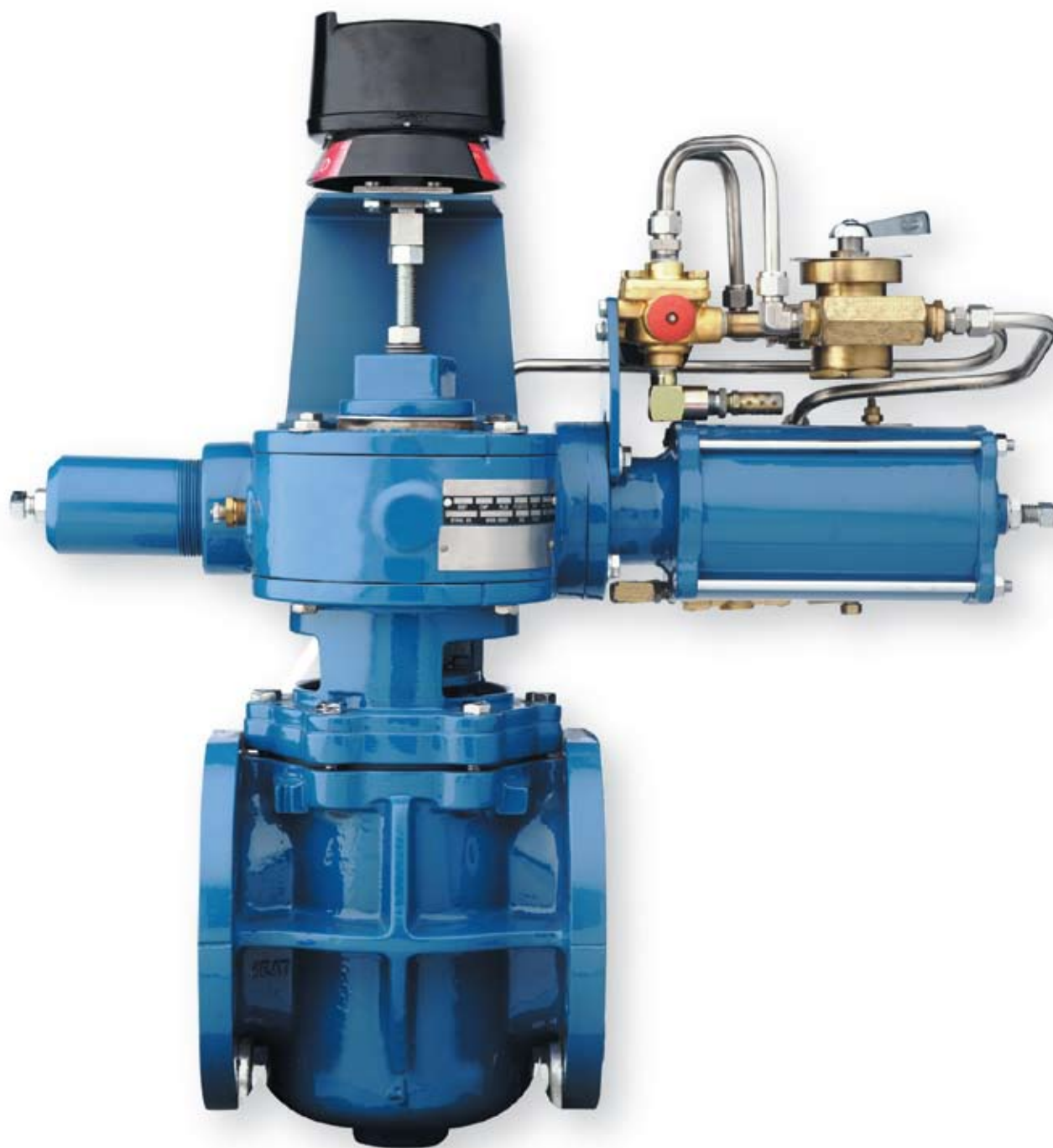

## PUMP CHECK VALVES



## Flexible Control With DeZURIK

Water hammer. Reverse Flow. Pump Backspin. Any number of conditions can cause expensive damage to pumps and piping systems. DeZURIK has been in the business of providing solutions to your pump system regulation needs for over 75 years. We can provide custom-designed and engineered systems for those precise flow regulation problems, or the powered Pump Check Valve that offers significant advantages over a gravity or spring-operated valve. For information on DeZURIK's vast array of Pump Check Systems and capabilities utilizing either Eccentric Plug Valve's or AWWA Butterfly Valves.

Typical applications of powered Pump Check Valve systems are municipal installations with long runs, hills or anywhere there are major changes in elevation. Pump Check Valves are also ideally suited for industrial process systems such as the primary cooling towers in the power generation industry.

## Advantages of Pump Check Valves

Water hammer can occur in any pipeline carrying incompressible fluids. The characteristic banging noise heard following an abrupt alteration in pressure due to rapid valve closure could easily cause expensive damage to pumps and piping systems.

The DeZURIK Pump Check Valve reduces the possibility of water hammer throughout the system by controlling valve opening and closing speeds so the operation does not cause pressure surges in either direction.

The Pump Check Valve performs all the necessary functions on a pump installation; it serves the purposes of both a swing check valve and an isolation valve, saving both cost and space.

## Advantages of Powered Operation

All pump installations require flow controls to check or stop back-flow through the pumping system. This can be accomplished through the use of a gravity or spring-operated pump check valve or a power actuated pump check valve.

Gravity or spring-operated check valves open and close with flow changes. An increase in flow pushes the valve open, a decrease allows gravity or spring force to close the valve. Because their operations are not controlled, these valves can stick or operate sporadically, which causes flow surges. Often, their flow capacities are low and they do not give tight shutoff.

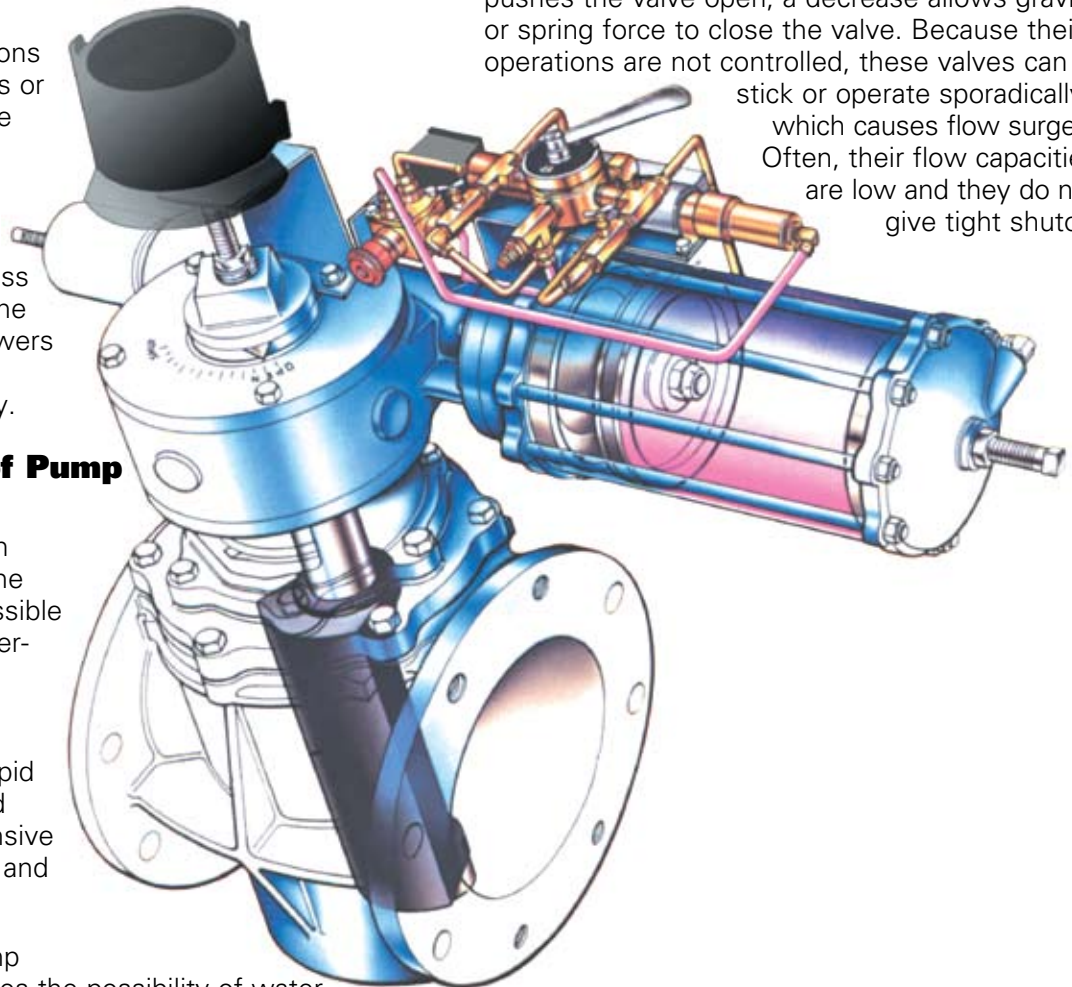

# Hydraulic

## Automatic Opening Cycle

1. With a decrease in system pressure or liquid level, contacts in the Remote Pressure Switch (PS-R) close, energizing the Motor Starter Coil (MSC), which closes the contacts of the Motor Starter (MS).
2. The Pump Motor starts and pumping pressure closes the Local Pressure Switch contacts (PS-L), energizing the Solenoid Pilot Valve (SPV). The Solenoid Pilot Valve transmits pressure to the switch valve and shifts its spool.
3. Hydraulic fluid or air enters the actuator and the valve begins opening at the preset speed.
4. As the pump output increases, the valve continues toward the open position.
5. Pump and valve reach 100% capacity at the same time, preventing a pressure build up at the valve and keeping the pump operating on its characteristic curve.

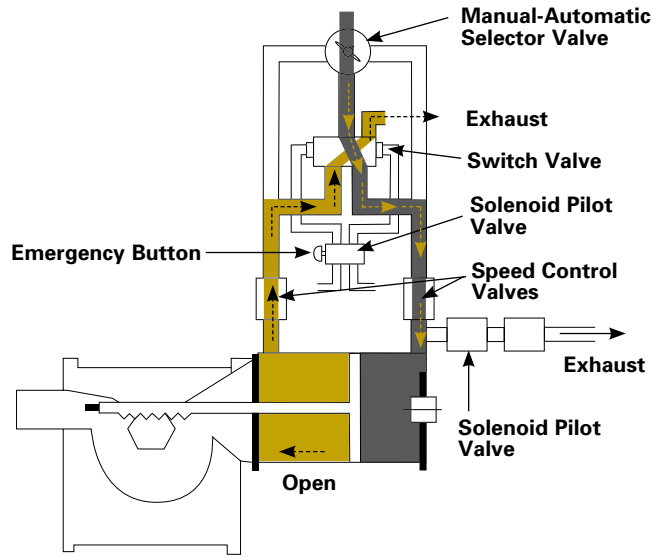

## Automatic Closing Cycle

1. When pressure or level requirements are satisfied, the Remote Pressure Switch (PS-R) contacts open and de-energize the Solenoid Pilot Valve (SPV). This causes the Pump Check Valve to begin closing at the preset speed.
2. The Pump Motor continues to run as the valve moves toward the closed position. The contacts on the Limit Switch then open at a preset point and de-energize the Motor Starter Coil (MSC), opening the Motor Starter (MS) contacts and stopping the pump.
3. As the pump slows down, the valve continues to close and shuts off tightly just as forward flow from the pump stops.
4. The system is again ready for the opening cycle.

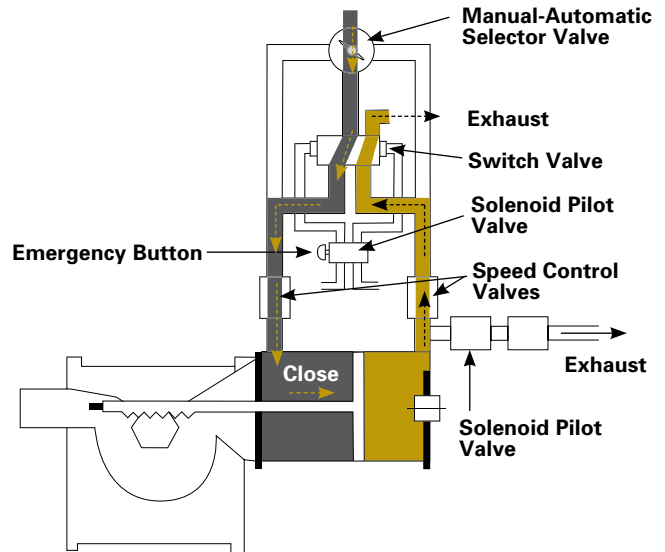

## Rapid Close Configuration

Optional rapid close pump check accessories are recommended for use whenever emergency shutdown is required. Operation is the same as with the standard configuration, except that the Solenoid Pilot Valve in cylinder port opens to provide auxiliary exhaust and to allow more rapid valve closing.

The optional accessories include an additional Solenoid Pilot Valve and a Speed Control Valve.

The system is wired so that upon power failure the Solenoid Pilot Valve de-energizes, providing emergency closing at the same rapid rate.

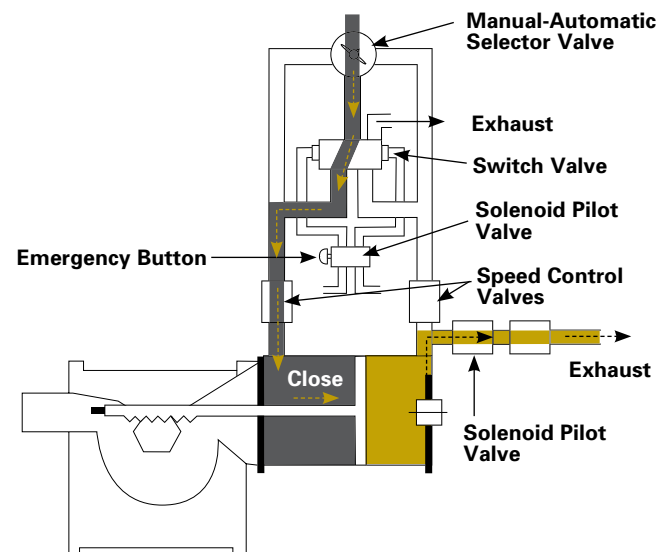

## Typical System

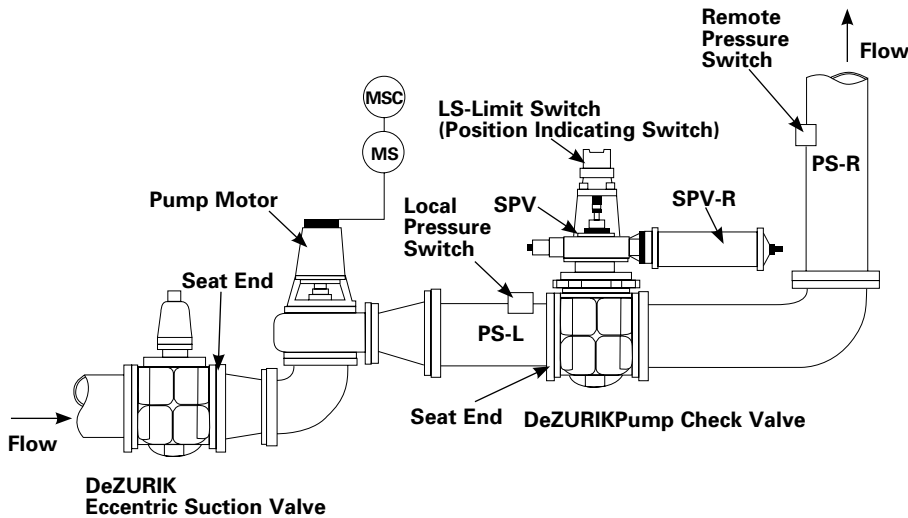

### Clean Water Service

Note: Consult Bulletin 12.00-1D for installation instructions

## Wiring Diagram

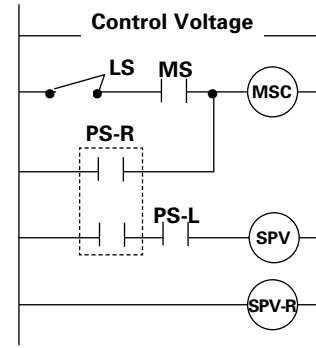

### Customer Supplied Components

- MSC = Motor Starter Coil
- PS-R = Remote Pressure Switch or Level Control
- PS-L = Local Pressure Switch

### Components Supplied by DeZURIK

- SPV = Solenoid Pilot Valve
- SPV-R = Solenoid Pilot Valve for Optional Rapid Close Accessories
- LS = Limit Switch — Opens at Preset Point

## Manual Operation

The system provides three methods of manual control:

### 1. Full Manual Operation

By turning the Manual-Automatic Selector Valve to the manual position, the actuator piping is isolated from supply pressure and pressure between opposing cylinder and supply lines is relieved. Using a wrench, the manual nut can usually operate most valves up to 10" (250mm). Auxiliary manual actuators and automatic fail-safe operating accessories can be furnished for all actuators.

### 2. Manual Override

The Solenoid Pilot Valve is equipped with a Manual Override Knob. Upon power failure, the manual override permits pneumatic or hydraulic opening of the valve.

### 3. Emergency Shutdown

Pressing an emergency button (supplied by customer) cuts electrical power to the motor. This stops the motor and pump. All electrical contacts to the valve are interrupted, de-energizing the Solenoid Pilot Valve. The valve then moves to its fully closed position. Please note, in this mode, back flow may occur, causing pump backspin.

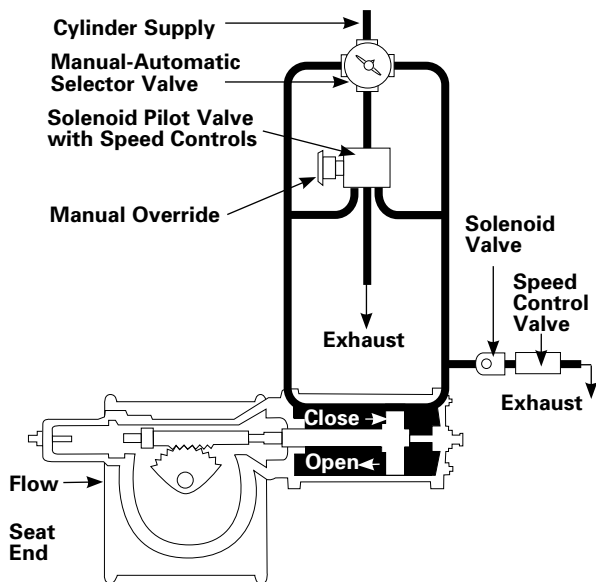

## **Power Actuated Pump Check Valves Precisely Regulate Flow**

The DeZURIK Pump Check Valve is a power actuated valve that provides precise flow regulation on all types of pumping installations.

By controlling valve opening and closing speed so that operation does not cause flow surges in either direction, the Pump Check Valve reduces water hammer and its deleterious effects. The DeZURIK Pump Check Valve also prevents reverse flow and pump back spin.

## **Automatic and Manual Control Options**

In addition to automatic control through either hydraulic or pneumatic actuators, the system is equipped to allow manual operation and also provide automatic shutdown in case of electrical failure.

## **Synchronized System is Field Adjustable**

The DeZURIK Pump Check Valve permits in-field adaptation to specific pumping system characteristics. Timing of the closing operation can be easily adjusted to synchronize with the water system, a distinct advantage over swing check valves where speed of operation is fixed.

## **Actuator Options Offer Control Versatility**

Double-acting actuators are available for either pneumatic or hydraulic supply. Heavy-duty cast actuator parts plus corrosion resistant bearings provide ruggedness throughout. Totally enclosed and sealed construction prevents the entry of dirt, liquids and corrosive atmospheres.

On hydraulic cylinders, epoxy coated wetted parts prevent corrosion. The multiple lip rod seal with adjustable gland does not require disassembly or replacement. A polyurethane scraper with metal backup is located inside the head of the cylinder to prolong seal life.

Most sizes up to 10" (250mm) can be wrench operated. Upon hydraulic or pneumatic supply failure, the failure position is the last position. Auxiliary actuators and fail-safe accessories are available. Double-acting pneumatic or hydraulic with 50–100 psi (345–690 kPa) cylinder supply. For actuator sizing recommendations, see DeZURIK Bulletin 12.00-1D.

For basic pumping systems, adjustable single-speed opening and adjustable single-speed closing are provided. Modifications to this unit can be made to achieve specific operating characteristics for individual installations.

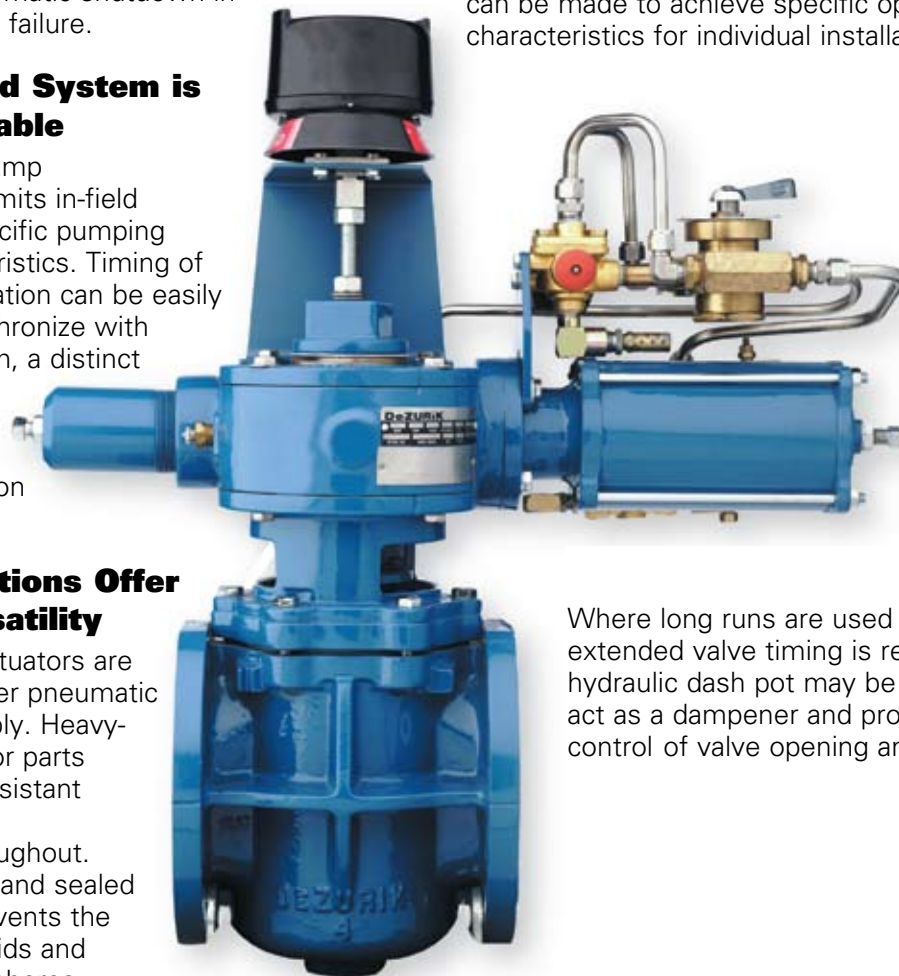

Where long runs are used and extended valve timing is required, a hydraulic dash pot may be added to act as a dampener and provide fine control of valve opening and closing.

## **Eccentric Plug Valves Ideally Suited for Pump Check Service**

- The modified linear characteristic of the DeZURIK eccentric makes it ideal for pump check installations. The modified linear characteristic allows more gradual flow rate changes for a given amount of valve travel as the valve nears the closed position. This slower rate of flow change reduces flow surges and the possibility of water hammer.
- The DeZURIK eccentric action principle moves the plug out of the flow area. The clean interior design and straight-through flow path result in low head loss and reduced pumping costs.
- DeZURIK eccentric action assures long plug and seat life because the plug contacts the seat only in the closed position. The resilient faced plug provides dead-tight shutoff on dirty service, even if small solids are trapped between the plug and seat.
- Resilient plug facings provide drip-tight shutoff up to the full valve rating with pressure in either direction allowing the Pump Check Valve to also be used as an isolation valve.
- Permanently lubricated, oil impregnated bearings in the bonnet and body of all valves ensure a lifetime of smooth operation — especially important on pump services with a high number of open and close cycles.
- Nickel and resilient seats both provide abrasion resistance required for the high flow conditions found on pump service.
- Eccentric Plug Valves are suitable for a wide range of services such as water, wastewater and other liquids, as well as slurries which cause leakage or plugging when trapped between the seat and plug.





## Special Configurations

In addition to the basic Pump Check Valve configurations described previously, we can provide special designs tailored to your installation requirements.

If you would like specific information or recommendations on a Pump Check Valve tailored to your requirements, contact DeZUIRK or your local representative. In either case, you will receive prompt answers to your specific questions.

Please furnish the following information:

1. Valve size or maximum flow and available pressure drop
2. Service conditions including flowing media and temperature
3. Description of system
4. Special operating characteristics required
5. Available cylinder supply
6. Available electrical supply
7. Required opening and closing time (in seconds)
8. System wiring diagram
9. Special electrical requirements

# Ordering

To order DeZURIK Pump Check Valves, specify the appropriate valve and actuator order code and add the order code for the pump check components required. Pump check components are available for either pneumatic or hydraulic actuators. Both pneumatic and hydraulic systems are also available with an optional rapid closing feature.

Supply line filters for pneumatic actuators and strainers for hydraulic actuators must be ordered for use with Pump Check Valves. Filters or strainers are unmounted and should be ordered as a separate item.

For PEC Eccentric Plug Valve Materials of Construction, Pressure Ratings, Ordering Information, Dimensions, Flow Characteristics, Actuator Sizing and other technical information, refer to 12.00-1D.

## Filter/Strainer

Supply line filters for pneumatic actuators and strainers for hydraulic actuators must be ordered for use with Pump Check Valves. Filters and strainers are unmounted and are ordered as a separate item.

Give filter/strainer code as follows:	
Description	Order Code

Pneumatic Filter	ACC*PCFP
Hydraulic Strainer	ACC*PCFH

**Ordering Example:**  
ACC\*PCFP



## EPP Standard Pump Check Accessories for Pneumatic Actuators

The following accessories are mounted and piped.

### 1. Solenoid Valve

Features manual override to control cylinder supply. NEMA 4, 7 and 9. Standard solenoid coil voltage is 120/60/1 power. Specify other characteristics as follows if required: 240/60/1; 110/50/1; 440/50/1; 480/60/1; 220/50/1.

### 2. Manual-Automatic Selector Valve

Provides bypass of solenoid valve to allow manual valve operation.

### 3. Position Indicating Switch

Provides remote indication of valve open and closed position. Limit switch opens at preset point. NEMA 4, 7 and 9. Switches are 2 SPDT or 1 DPDT, specify switch configuration. Additional switches may be specified as second line information.

### 4. Two Speed Control Valves

Two furnished on supply lines of cylinder to allow adjustment of operating speed.

## EPH Standard Pump Check Accessories for Water or Oil Hydraulic Actuators

### 1. Solenoid Valve

Features manual override and acts as a pilot to operate a 4-way switch valve. NEMA 4, 7 and 9. Standard solenoid coil voltage is 120/60/1 power. Specify other characteristics as follows if required: 240/60/1; 110/50/1; 440/50/1; 480/60/1; 220/50/1.

### 2. Switch Valve

Controls cylinder supply.

### 3. Manual-Automatic Selector Valve

Bypasses the 4-way switch valve and allows manual operation of valves up to 10" (250mm) size.

### 4. Speed Control Valves

Two furnished on supply lines of cylinder to allow adjustment of operating speed.

### 5. Position Indicating Switch

Provides remote indication of valve open and closed position. Limit switch opens at preset point. NEMA 4, 7 and 9. Switches are 2 SPDT or 1 DPDT, specify switch configuration. Additional switches may be specified as second line information.

## EPPR and EPHR Rapid Close Accessories

EPPR for pneumatic and EPHR for hydraulic pump check actuators provide faster operating speeds than standard pump check accessories. Refer to Operating Speeds table below. Rapid close accessories are normally used to provide rapid system shutdown under emergency conditions. The rapid close accessories include an additional solenoid that is piped to the cylinder to bypass the normal solenoid exhaust and allow rapid valve closing. Electrical characteristics are the same as the standard solenoids. An additional speed control valve allows adjustment of closing speed. Components are mounted and piped.

### Speed of Operation

Fastest obtainable operating times for standard and rapid close pump check accessories are shown below. Speeds can be slowed by adjusting speed control valves.

With pneumatic actuators and applications involving long closing times, the addition of a hydraulic dampener cylinder is recommended. For faster speeds and for operating speeds on valves 36" (900mm) and larger, contact DeZURIK.

### Operating Speeds (Seconds)

Actuator Model Code	Pneumatic Actuators		Hydraulic Actuators	
	Standard	Rapid Close	Standard	Rapid Close
GS-6-PC6	2	1.2	20	15
GS-6-PC8	5	3	30	20
GS-12-PC6	5	3	45	30
GS-12-PC8	7	5	60	40
GS-12-PC10	12	9	90	60
GS-16-PC8	12	9	90	60
GS-16-PC10	17	13	120	90
GS-16-PC12	23	17	120	90

### Ordering Example:

PEC,6,F1,CI,NBR,CR\*GS-6-HD6,EPHR

## **Sales and Service**

For information about our worldwide locations, approvals, certifications and local representative:

Web Site: [www.dezurik.com](http://www.dezurik.com) E-Mail: [info@dezurik.com](mailto:info@dezurik.com)



250 Riverside Ave. N. Sartell, Minnesota 56377 • Phone: 320-259-2000 • Fax: 320-259-2227

*DeZURIK reserves the right to incorporate our latest design and material changes without notice or obligation. Design features, materials of construction and dimensional data, as described in this bulletin, are provided for your information only and should not be relied upon unless confirmed in writing by DeZURIK. Certified drawings are available upon request.*