

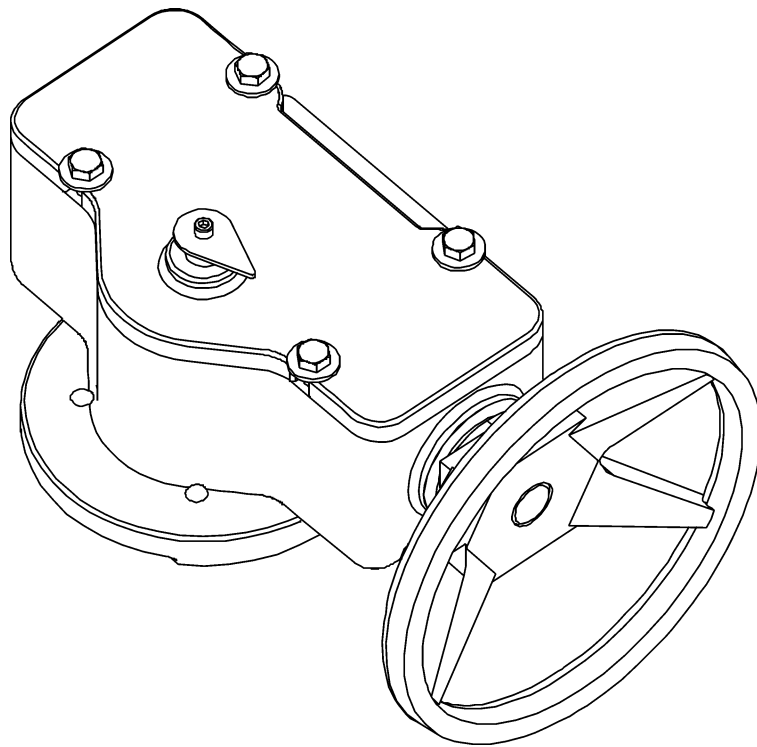

# DeZURIK M-SERIES MANUAL ACTUATOR



Instruction D10287

June 2011

# DeZURIK

## M-Series Manual Actuator

---

### Instructions

These instructions provide information about Manual M-Series Manual Actuators. They are for use by personnel who are responsible for installation, operation and maintenance of M-Series Manual Actuators.

### Safety Messages

All safety messages in the instructions are flagged with an exclamation symbol and the word Caution, Warning or Danger. These messages indicate procedures that must be followed exactly to avoid equipment damage, personal injury or death.

Safety label(s) on the product indicate hazards that can cause equipment damage, personal injury or death. If a safety label becomes difficult to see or read, or if a label has been removed, please contact DeZURIK for replacement label(s).



#### **WARNING!**

**Personnel involved in the installation or maintenance of valves should be constantly alert to potential emission of pipeline material and take appropriate safety precautions. Always wear suitable protection when dealing with hazardous pipeline materials. Handle valves, which have been removed from service with suitable protection for any potential pipeline material in the valve.**

---

### Inspection

Your M-Series Manual Actuator has been packaged to provide protection during shipment, however, it can be damaged in transport. Carefully inspect the unit for damage upon arrival and file a claim with the carrier if damage is apparent.

### Parts

Recommended spare parts are listed on the assembly drawing. These parts should be stocked to minimize downtime.

Order parts from your DeZURIK sales representative, or directly from DeZURIK. When ordering parts, please include the 7-digit part number and 4-digit revision number (example: **9999999R000**) located on the data plate attached to the valve assembly. Also include the part name, the assembly drawing number, the balloon number and the quantity stated on the assembly drawing.

### DeZURIK Service

DeZURIK service personnel are available to install, maintain and repair all DeZURIK products. DeZURIK also offers customized training programs and consultation services.

For more information, contact your local DeZURIK sales representative or visit our website at [www.dezurik.com](http://www.dezurik.com).

## Table of Contents

Description - - - - -	4
Operation - - - - -	4
Required Tools - - - - -	4
Lubrication - - - - -	4
Spare Parts - - - - -	4
Drawings - - - - -	5
Position Stops - - - - -	6
Disassembly - - - - -	6
Reassembly and Installation - - - - -	6
Setting Position Stops - - - - -	7
Troubleshooting - - - - -	8

# DeZURIK

## M-Series Manual Actuator

---

### Description

The M3 & M7 M-Series Manual Actuators have a fully enclosed scotch yoke mechanism driven by a handwheel, chainwheel or 2" nut. The actuator is available as weatherproof or buriable, and has internally adjustable stops. The actuator conforms to the applicable requirements of ANSI/AWWA Standard C504.

The actuator is sized for the valve and shutoff pressure specified. Consult the factor for sizing information if the actuator is used for other applications. The actuator is available for both 300 ft. lb. input and 450 ft. lb. input. The 450 ft. lb. style has two guide blocks in addition to the guide rail used in both styles.

### Operation

Clockwise rotation of the actuator input shaft closes the valve, and counterclockwise rotation opens the valve. The M3 requires 29-1/4 turns, and the M7 requires 42 turns of the input shaft to drive the actuator the 90 degrees from one position to the other.

### Required Tools

The actuator is assembled with SAE fasteners. Tools required for adjustment and disassembly include a set of combination wrenches, a flat-tipped screwdriver, a set of Allen wrenches, a pin punch, a file and a small hammer.

### Lubrication

The actuator does not require lubrication for routine maintenance. If the actuator is disassembled, however, lubricate all bearing, sealing and threaded surfaces of the components listed below with EXXON Unirex EP 2 Premium lubricant (**recommended**) or Petro-Canada Precision XL EP 2 (alternate) during assembly. See Figure 1 for parts location.

- Actuator shaft, O-ring and bearing
- Shaft threads
- Collar(s)
- Both stop nuts
- Inner and outer thrust washer, both sides
- Guide blocks
- Yoke guide
- Yoke nut
- Yoke slots
- Yoke bearing sides
- Bearing and O-ring where the valve shaft enters the actuator housing

After the actuator is fully assembled, apply a layer of lubricant approximately 1/2" thick to the above surfaces that are accessible inside the housing. For buried service applications, continue to apply lubricant until the housing is 90% filled.

### Spare Parts

Recommended spare parts are listed below. Replace worn parts as described below.

- Housing bearing
- Yoke nut assembly
- Thrust washers
- O-ring for valve shaft
- O-ring for actuator shaft

Drawings

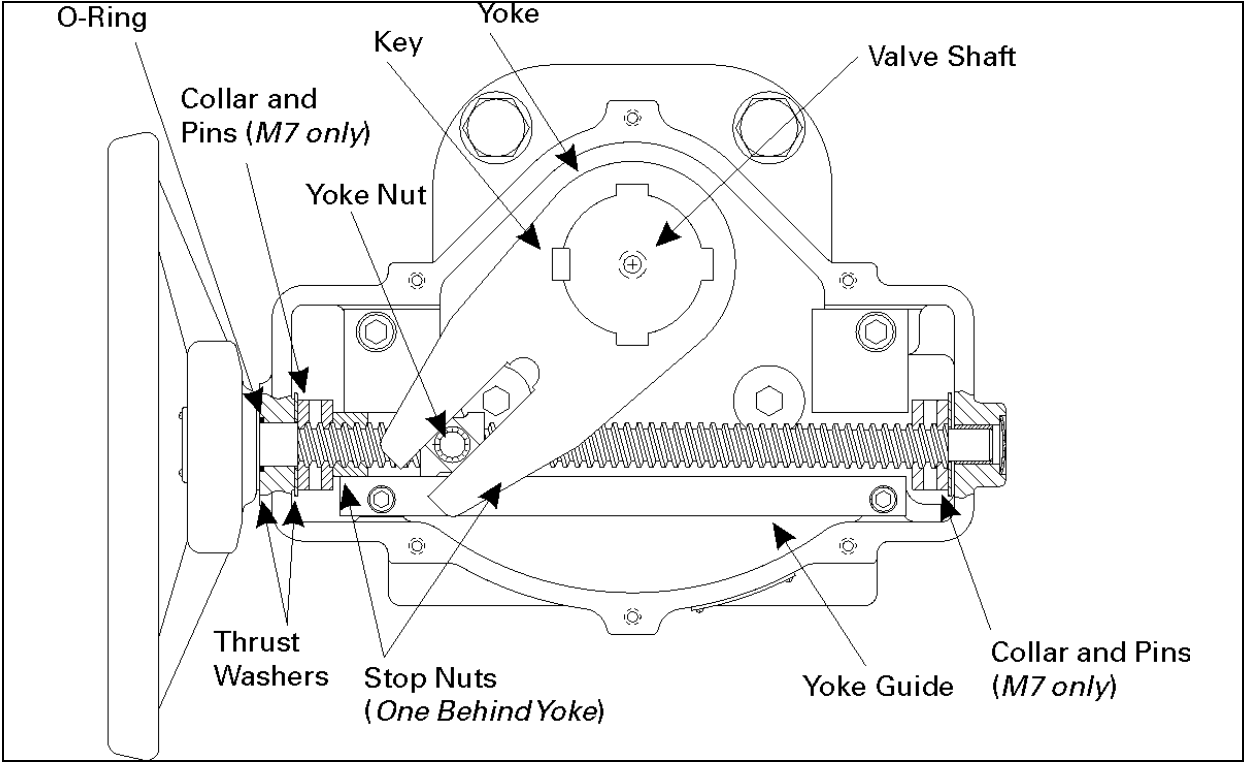

Figure 1—Top View

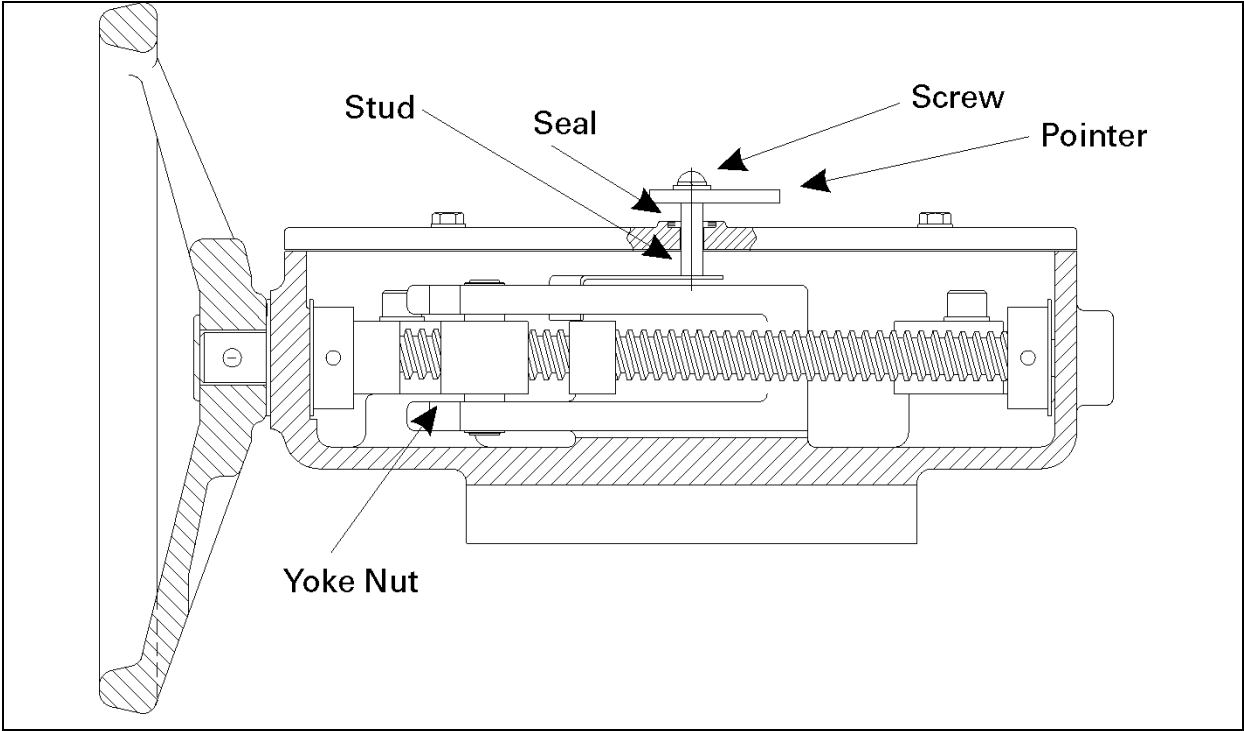

Figure 2— Side View

### Position Stops

The position stops prevent the actuator from going beyond the open and closed positions of the valve. The stops are preset and do not require further adjustment. If the actuator is disassembled, however, the stops may require readjustment as described in ASSEMBLY and INSTALLATION.

### Disassembly

---



#### **WARNING!**

**This actuator retains the stem packing in the valve.**

**Removing the actuator while the valve is under pressure can cause personal injury and equipment damage. Relieve pressure in the valve before removing the actuator.**

---

1. Relieve the pressure and flow in the pipeline and close the valve.
2. If the actuator has a pointer, remove the pointer screw, pointer and lockwasher.
3. Remove the cover screws and cover from actuator.
4. Drive the pins out of the collar(s). The pins are roll pins and can be driven straight through toward the bottom of the housing.
5. Remove the guide blocks and yoke guide.
6. Unscrew the shaft from the collars, the stop nuts and the yoke nut.
7. Remove the shaft from the actuator housing
8. Remove all of the shaft components from the housing.
9. Remove the yoke from the valve shaft. Keep the drive key with the yoke.
10. Remove the three actuator mounting screws, and remove the housing from the valve.

### Reassembly and Installation

1. Clean all parts and remove old sealant from the actuator cover.
2. Restore the key and keyway in the valve shaft to original condition.
3. If the valve shaft bearing in the bottom of the housing is worn, replace it.
4. Install a new O-ring outside the valve shaft bearing.
5. Set actuator housing on valve. Make sure relief groove on bottom of actuator is open.
6. Insert the three screws that fasten actuator housing to the valve. Tighten the inside screw first.
7. If yoke nut bearings and retainers are worn, replace them.
8. Inspect the holes near the ends of the actuator shaft, and remove any burs made when the pins were removed during disassembly.
9. Insert yoke nut assembly into yoke and install both on valve shaft.
10. Slide thrust washer onto actuator shaft.

## Reassembly and Installation *(Continued)*

11. Start shaft into actuator, installing internal parts on the shaft as follows:
  - a. **M3** - thrust washer, collar (chamfer toward middle of actuator), smaller stop nut, yoke nut and larger stop nut.
  - b. **M7** - thrust washer, collar (chamfer toward middle of actuator), stop nut, yoke nut, stop nut and collar (chamfer toward middle of actuator). If one collar has a "D" stamped on its O.D., it goes on the shaft first.
12. Continue to rotate and push the shaft until its small end is inserted into the bearing in the opposite end of the housing.
13. Move the collars along the shaft at both ends until the holes in the collars and shaft are aligned.
14. Drive the two pins into each collar.
15. Assemble actuator to obtain clockwise rotation to close the valve. With valve in fully closed position and actuator assembled w/yoke, rotate shaft until yoke is in the fully CW position as viewed from top of actuator. Make minor adjustments to align one of the keyways in the actuator yoke with the single keyway in the valve shaft.
16. Drive the key between the valve shaft and the actuator yoke until it is flush with the top of the shaft. Do not "mushroom" the end of the key.
17. Center punch end of valve shaft on each side of key to retain key in keyway.
18. Complete the assembly by following steps 2 -12 in Setting Stops.

## Setting Position Stops

1. Remove yoke guide and guide blocks if present.
2. Thread stop nuts along shaft to get desired open and closed positions of valve. To get longer stroke, move stop nuts toward middle of actuator.
3. Install guide blocks and yoke guide, and start screws into actuator. Leave screws loose.
4. Operate valve to full open and closed positions to check locations of stop nuts.
5. If open or closed position is not satisfactory, follow steps 1 through 4 above. If open and closed positions are both satisfactory, go to next step.
6. Tighten screws for guide blocks (on 450-foot-pound style only) and yoke guide as follows: while using a screwdriver to hold the yoke guide and guide blocks away from the actuator shaft, tighten the screws.
7. Move the actuator to the closed position.
8. Fill actuator with lubricant.
9. Clean the mating surfaces on the actuator housing and cover.
10. Using RTV or another silicone-based sealant, form a gasket on the mating surface of the actuator housing.
11. Install the actuator cover.
12. If the actuator has a pointer, install the lock washer, pointer (pointing to "CLOSED") and screw in that order.

# DeZURIK

## M-Series Manual Actuator

---

### Troubleshooting

Symptom	Possible Cause	Corrective Action
Actuator closes to wrong position.	Closed position stop is set incorrectly.	Adjust closed position stop.
Actuator opens to wrong position.	Open position stop is set incorrectly.	Adjust open position stop.
Actuator won't close.	Obstruction in valve is preventing closure.	Remove obstruction.
Wrenching square turns, but actuator doesn't turn.	Pin in wrenching square is sheared.	Replace pin.
Actuator turns, but valve doesn't.	Valve shaft key in yoke is sheared.	Replace key.
Rotation direction of wrenching square is incorrect.	Yoke-to-shaft key is 90° off.	Disengage actuator yoke from valve shaft, turn 90° and re-engage.