



**ENK NECK EXTENSION  
USED WITH G-SERIES ACTUATORS  
ON PEC ECCENTRIC VALVES**

# DeZURIK - ENK Neck Extension

## Used With G-Series Actuators On PEC Eccentric Valves

---

### Instructions

These instructions provide information about ENK Neck Extensions. They are for use by personnel who are responsible for installation, operation and maintenance of ENK Neck Extensions.

### Safety Messages

All safety messages in the instructions are flagged with an exclamation symbol and the word Caution, Warning or Danger. These messages indicate procedures that must be followed exactly to avoid equipment damage, personal injury or death. Safety label(s) on the product indicate hazards that can cause equipment damage, personal injury or death. If a safety label becomes difficult to see or read, or if a label has been removed, please contact DeZURIK for replacement label(s).



#### **WARNING!**

**Personnel involved in the installation or maintenance of valves should be constantly alert to potential emission of pipeline material and take appropriate safety precautions. Always wear suitable protection when dealing with hazardous pipeline materials. Handle valves that have been removed from service with the assumption of pipeline material within the valve.**

---

### Inspection

Your ENK Neck Extension has been packaged to provide protection during shipment; however, it can be damaged in transport. Carefully inspect the unit for damage upon arrival and file a claim with the carrier if damage is apparent.

### Parts

Recommended spare parts are listed on the assembly drawing. These parts should be stocked to minimize downtime.

Order parts from your local DeZURIK sales representative, or directly from DeZURIK. When ordering parts, please include the 7-digit part number and 4-digit revision number (example: **9999999R000**) located on the data plate attached to the valve assembly. Also include the part name, the assembly drawing number, the balloon number and the quantity stated on the assembly drawing.

### DeZURIK Service

DeZURIK service personnel are available to install, maintain and repair all DeZURIK products. DeZURIK also offers customized training programs and consultation services.

For more information, contact your local DeZURIK sales representative or visit our website at [www.dezurik.com](http://www.dezurik.com).

## **Table of Contents**

Description - - - - -	4
Disassembly - All Valve Sizes - - - - -	4
Disassembly - 4" thru 20" Valves - - - - -	4
<i>To remove the actuator from the extension</i> - - - - -	4
<i>To remove the extension from the valve</i> - - - - -	4
Reassembly - 4" thru 20" Valves - - - - -	5
<i>To replace the extension on the valve</i> - - - - -	5
<i>To replace the actuator on the extension</i> - - - - -	5
Disassembly - 24" thru 36" Valves - - - - -	6
<i>To remove the actuator from the extension</i> - - - - -	6
<i>To remove the extension from the valve</i> - - - - -	6
Reassembly - 24" thru 36" Valves - - - - -	7
<i>To replace the extension on the valve</i> - - - - -	7
<i>To replace the actuator on the extension</i> - - - - -	7

# DeZURIK - ENK Neck Extension

## Used With G-Series Actuators On PEC Eccentric Valves

---

### Description

The ENK Neck Extension is located between the valve and the valve actuator, and is used to extend the distance from the valve to the actuator. The actuator consists of a stationary outer extension and a rotating inner extension. The outer extension mounts the actuator to the valve; the inner extension is a drive shaft to transmit the torque from the actuator to the valve. This document provides instructions for the extension used with a G-Series Actuator on PEC Eccentric Valves.

### Disassembly - All Valve Sizes

Before disassembly, relieve the pressure and stop the flow in the pipeline.



#### **WARNING!**

Relieve the pressure and stop the flow in the pipeline. Pressure and/or flow with the extension or actuator removed can cause the valve to slam closed, and can cause water hammer damage to the valve and other pipeline equipment.

---



#### **WARNING!**

This valve is a pressure vessel. On 4, 5, 6 and 10" valves, the same bolts hold both the extension and the bonnet. Removing the bolts on 4, 5, 6 and 10" valves before relieving pipeline pressure can result in personal injury or equipment damage. Always relieve pipeline pressure before removing the extension.

---

### Disassembly - 4" thru 20" Valves

#### ***To remove the actuator from the extension***

1. Remove the lock nut, spring washers, wrenching square, and pointer from the top of the actuator.
2. Remove the cover screws and the cover from the actuator.
3. Note the orientation of the actuator gear with respect to the extension drive shaft.
4. Remove the screws that mount the actuator to the extension, and lift the actuator from the extension.

#### ***To remove the extension from the valve***

1. Remove the locknut, spring washers, wrenching square, and pointer from the top of the actuator.
2. Remove the mounting screws that mount the outer extension to the valve, and lift the outer extension and actuator from the valve.
3. Remove the drive pin that fastens the inner extension to the valve stem, and remove the inner extension from the valve. Before reassembly, remove the gaskets or sealant from all mating mounting surfaces. If gaskets were used, do not reuse the gaskets; apply a thin bead of silicone sealant to one of the mating surfaces. Apply the sealant between the inside diameter and the mounting hole pattern.

**DeZURIK - ENK Neck Extension**  
**Used With G-Series Actuators On PEC Eccentric Valves**

---

## **Reassembly - 4" thru 20" Valves**

Before reassembly, remove the gaskets or sealant from all mating mounting surfaces. If gaskets were used, do not reuse the gaskets; apply a thin bead of silicone sealant to one of the mating surfaces. Apply the sealant between the inside diameter and the mounting hole pattern.

### ***To replace the extension on the valve***

1. Align the pin holes, and place the inner extension on the valve stem. Replace the drive pin in the holes.
2. Mount the extension to the valve with the mounting screws, and tighten the screws. On valve sizes 4", 5", 6", and 10", the extension is mounted with the valve bonnet screws.

### ***To replace the actuator on the extension***

1. Place the actuator on the extension, and engage the extension with the actuator gear so that the open and closed positions of the actuator match the open and closed positions of the valve.
2. Mount the actuator to the extension with the mounting screws, and tighten the screws.
3. Mount the cover to the actuator with the cover screws, and tighten the screws.
4. Place the pointer, wrenching square, spring washers, and locknut on the stud on the top of the actuator. Stack the spring washers in series as shown in Figure 1.
5. Tighten the locknut until the spring washers are fully compressed; then loosen the locknut until the spring washers return to their unstressed shape.

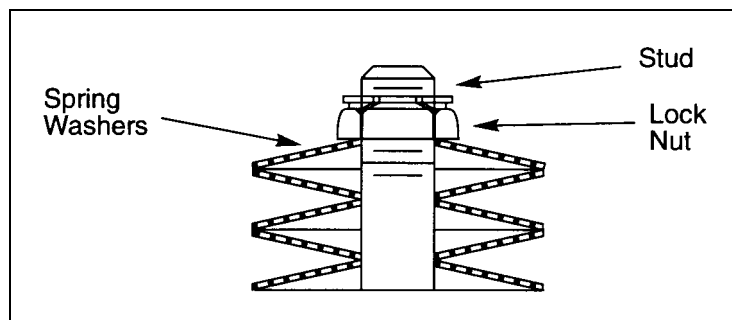

**Figure 1 - Spring Washer Arrangement**

**DeZURIK - ENK Neck Extension**  
**Used With G-Series Actuators On PEC Eccentric Valves**

---

**Disassembly - 24" thru 36" Valves**

Before disassembly, scribe a witness mark on each side of the flanged connections between the actuator, extension, and housing. The witness marks will be helpful in aligning the connections during reassembly.

**To remove the actuator from the extension**

1. Loosen the two sets of lockscrews #1 and #2 on the top of the actuator as shown in Figure 2. Loosen lockscrews #1 about 6 to 8 turns; loosen lockscrews #2 about 3 turns. Tap both lockscrews #1 with a soft hammer to loosen the keys.

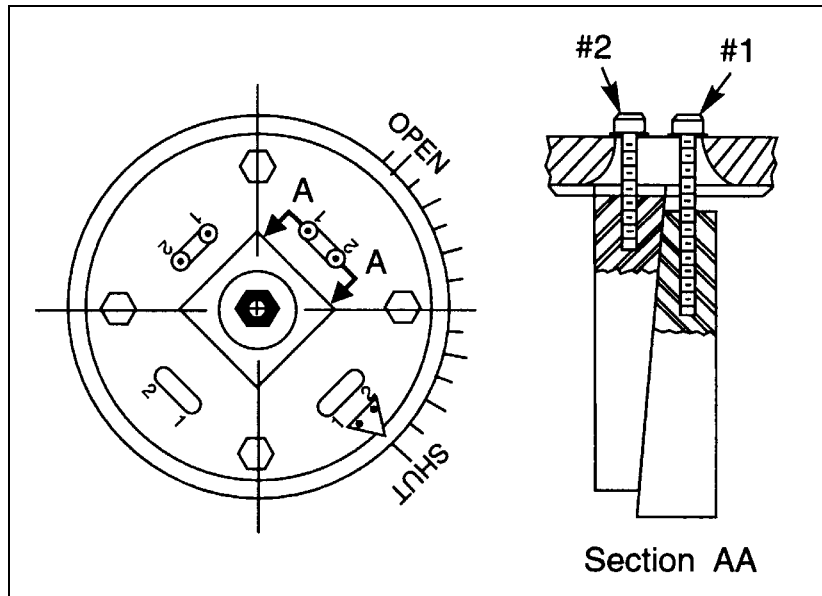

**Figure 2 - Actuator Lockscrews**

2. Remove the nut and spring washers from the stud on top of the actuator.
3. Remove the four screws that mount the wrenching square to the actuator gear. Then remove the wrenching nut with the keys attached.
4. Remove the screws that mount the actuator to the extension, and lift the actuator from the extension.

**To remove the extension from the valve**

1. Remove the screws that mount the outer extension to the housing, and remove the outer extension from the housing.
2. Remove the screws that mount the inner extension to the drive assembly, and remove the inner extension from the drive assembly.

## **Reassembly - 24" thru 36" Valves**

Before reassembly, remove the gaskets or sealant from all mating mounting surfaces. If gaskets were used, do not reuse the gaskets; apply a thin bead of silicone sealant to one of the mating surfaces. Apply the sealant between the inside diameter and the mounting hole pattern.

During reassembly, align the witness marks (scribed before disassembly) on each side of the flanged connections between the actuator, extension, and housing.

### ***To replace the extension on the valve***

1. Mount the inner extension to the drive assembly with the mounting screws, and tighten the screws.
2. Mount the outer extension to the housing with the mounting screws, and tighten the screws.

### ***To replace the actuator on the extension***

1. Place the actuator on the extension, and engage the extension with the actuator gear so that the open and closed positions of the actuator match the open and closed positions of the valve.
2. Mount the actuator to the extension with the mounting screws, and tighten the screws.
3. Place the wrenching nut — with the four keys attached — over the stud in the inner extension so that the pointer indicates the valve position, and guide the keys into position into the slots formed by the actuator gear and the drive of the inner extension.
4. Mount the wrenching square to the actuator gear with the four mounting screws, and tighten the screws.
5. Place the spring washers and locknut on the stud as shown in Figure 1, and tighten the locknut until the washers are fully compressed; then loosen the locknut until the spring washers return to their unstressed shape.
6. Refer to Figure 2. Tighten the two lockscrews #2; then tighten the two lockscrews #1 to secure the keys in position.