



# MASTERGEAR MANUAL ACTUATOR

# DeZURIK

## Mastergear Manual Actuator

---

### Instructions

These instructions provide information about Mastergear Manual Actuators. They are for use by personnel who are responsible for installation, operation and maintenance of Mastergear Manual Actuators.

### Safety Messages

All safety messages in the instructions are flagged with an exclamation symbol and the word Caution, Warning or Danger. These messages indicate procedures that must be followed exactly to avoid equipment damage, personal injury or death.

Safety label(s) on the product indicate hazards that can cause equipment damage, personal injury or death. If a safety label becomes difficult to see or read, or if a label has been removed, please contact DeZURIK for replacement label(s).



#### **WARNING!**

**Personnel involved in the installation or maintenance of valves should be constantly alert to potential emission of pipeline material and take appropriate safety precautions. Always wear suitable protection when dealing with hazardous pipeline materials. Handle valves which have been removed from service with the assumption of pipeline material within the valve.**

---

### Inspection

Your Mastergear Manual Actuator has been packaged to provide protection during shipment, however, it can be damaged in transport. Carefully inspect the unit for damage upon arrival and file a claim with the carrier if damage is apparent.

### Parts

Recommended spare parts are listed on the assembly drawing. These parts should be stocked to minimize downtime.

Order parts from your local DeZURIK sales representative, or directly from DeZURIK. When ordering parts, please include the 7-digit part number and 4-digit revision number (example: **9999999R000**) located on the data plate attached to the valve assembly. Also include the part name, the assembly drawing number, the balloon number and the quantity stated on the assembly drawing.

### DeZURIK Service

DeZURIK service personnel are available to install, maintain and repair all DeZURIK products. DeZURIK also offers customized training programs and consultation services.

For more information, contact your local DeZURIK sales representative or visit our website at [www.dezurik.com](http://www.dezurik.com).

<b>Table of Contents</b>	Description .....	2
	Operation .....	2
	Lubrication .....	2
	Adjustments	
	<i>To adjust the closed position stop:</i> .....	2
	<i>To adjust the open position stop:</i> .....	2
	Removing Actuator from Valve .....	3
	Replacing Actuator on Valve .....	3
	Replacing Handwheel with Chainwheel .....	5
	Replacing Chainwheel with Handwheel .....	6
	Changing Actuator Mounting Position on Valve .....	6
	Lockout Device	
	<i>Adding Lockout to MG-30 Actuator</i> .....	6
	<i>Adding Lockout to Other Actuators</i> .....	7
Troubleshooting .....	8	

# DeZURIK

## Mastergear Manual Actuator

---

**Description** The Mastergear Manual Actuator is a quarter-turn gear actuator. The actuator is available in four sizes, with a choice of handwheel, chainwheel, or 2" (50 mm) square nut. Each actuator has adjustable open and closed position stops, and may be mounted on the valve in any of four mounting positions, depending upon valve type.

As an option, the handwheel actuator is available with a lockout device that allows the handwheel to be secured with a padlock.

**Operation** Clockwise rotation of the handwheel, chainwheel, or 2" (50 mm) nut drives the actuator and valve clockwise towards the closed position of the valve, and counterclockwise rotation opens the valve. The approximate number of handwheel or chainwheel turns to drive the valve 90° are 8 turns on the MG-30 and MG-31, 12 turns on the MG-46, and 16 turns on the MG-64. With the optional lockout device, the handwheel may be locked with a padlock at any 1/8-turn increment.

**Lubrication** The actuator is lubricated at the factory, and does not require further lubrication.

**Adjustments** The open and closed position stops prevent the actuator from rotating beyond the open and closed positions of the valve. Each stop is adjustable. If the actuator is factory-mounted on the valve, the stops are preset, and do not require further adjustment.

If the actuator is not factory mounted on the valve, or if the actuator has been removed, the stops will require adjustment as described below. Refer to Figure 1 for component identification; also refer to the Valve Instructions for specific closed-position requirements for the valve.

***To adjust the closed position stop:***

1. Loosen the jam nut on the closed position stop screw, and back out the stop screw about two turns.
2. Turn the handwheel or chainwheel so that the valve is in the closed position.
3. Turn the closed position stop screw clockwise until resistance is felt from the stop screw contacting the gear inside of the actuator.
4. Hold the stop screw from turning, and tighten the jam nut to the torque in Table A.

***To adjust the open position stop:***

1. Loosen the jam nut on the open position stop screw, and back out the stop screw about two turns.
2. Turn the handwheel or chainwheel so that the valve is in the open position.
3. Turn the open position stop screw clockwise until resistance is felt from the stop screw contacting the gear inside of the actuator.
4. Hold the stop screw from turning, and tighten the jam nut to the torque in Table A.

**Removing Actuator from Valve**

Refer to Figure 1 for component identification.



**WARNING!**

**Flow in the pipeline with the actuator removed can slam the valve closed causing personal injury and damaging the flow system. Shut down the flow in the pipeline before removing the actuator from the valve.**

1. Close the valve.
2. Remove the four mounting screws (B6) and lockwashers (B7).
3. Remove the actuator from the valve.

**Replacing Actuator on Valve**

Refer to Figure 1 for component identification.

1. Place both the actuator and the valve in the closed position.
2. Some actuators include a splined drive bushing (B2) as indicated in Figure 1. If the actuator includes a bushing, but the bushing has come out of the actuator, note that one large tooth in the bushing is marked with an arrow. Place the bushing in the actuator so that the large tooth is engaged with the deep V-shaped groove in the actuator.
3. Select the desired actuator mounting position from the optional positions shown on the Installation Drawing. Place the gasket in position (see note below), engage the actuator with the valve shaft, and slide the actuator into position on the top of the valve.

**Note:** All chainwheel actuators include and use a 1/32" (0.8 mm) thick gasket (B28) between the actuator and the chainwheel support (B29). Handwheel actuators do not include a gasket. However, with high-temperature valves, a 1/16" (1.6 mm) thick insulating gasket (P5) is used on handwheel actuators, and is added under the chainwheel support on chainwheel actuators. The insulating gasket is used only when the gasket is included with the valve.

4. Mount the actuator and gasket (see note above) to the valve with the four mounting screws (B6) and lockwashers (B7). Tighten the screws as shown in Table A.
5. Adjust the open and closed position stops as shown in the Adjustments section.

**Table A: Fastener Torque Requirements**

Fastener	Actuator Size							
	MG-30		MG-31		MG-46		MG-64	
	foot lbs	Nm	foot lbs	Nm	foot lbs	Nm	foot lbs	Nm
Open and Closed Position Stop Nuts	9 ± 1	12 ± 1	47 ± 6	64 ± 8	83 ± 10	113 ± 14	215 ± 30	290 ± 40
Actuator Mounting Screw (B6) CS is Carbon Steel; SS is Stainless Steel	23 ± 3 CS 16 ± 2 SS	31 ± 4 CS 22 ± 3 SS	83 ± 10 CS 58 ± 8 SS	113 ± 14 CS 79 ± 11 SS	435 ± 60 foot lbs (590 ± 80 Nm) CS 300 ± 40 foot lbs (400 ± 50 Nm) SS			
Chainwheel Set Screw (B18)	7 ± 1 foot lbs (9 ± 1 Nm)							

# DeZURIK Mastergear Manual Actuator

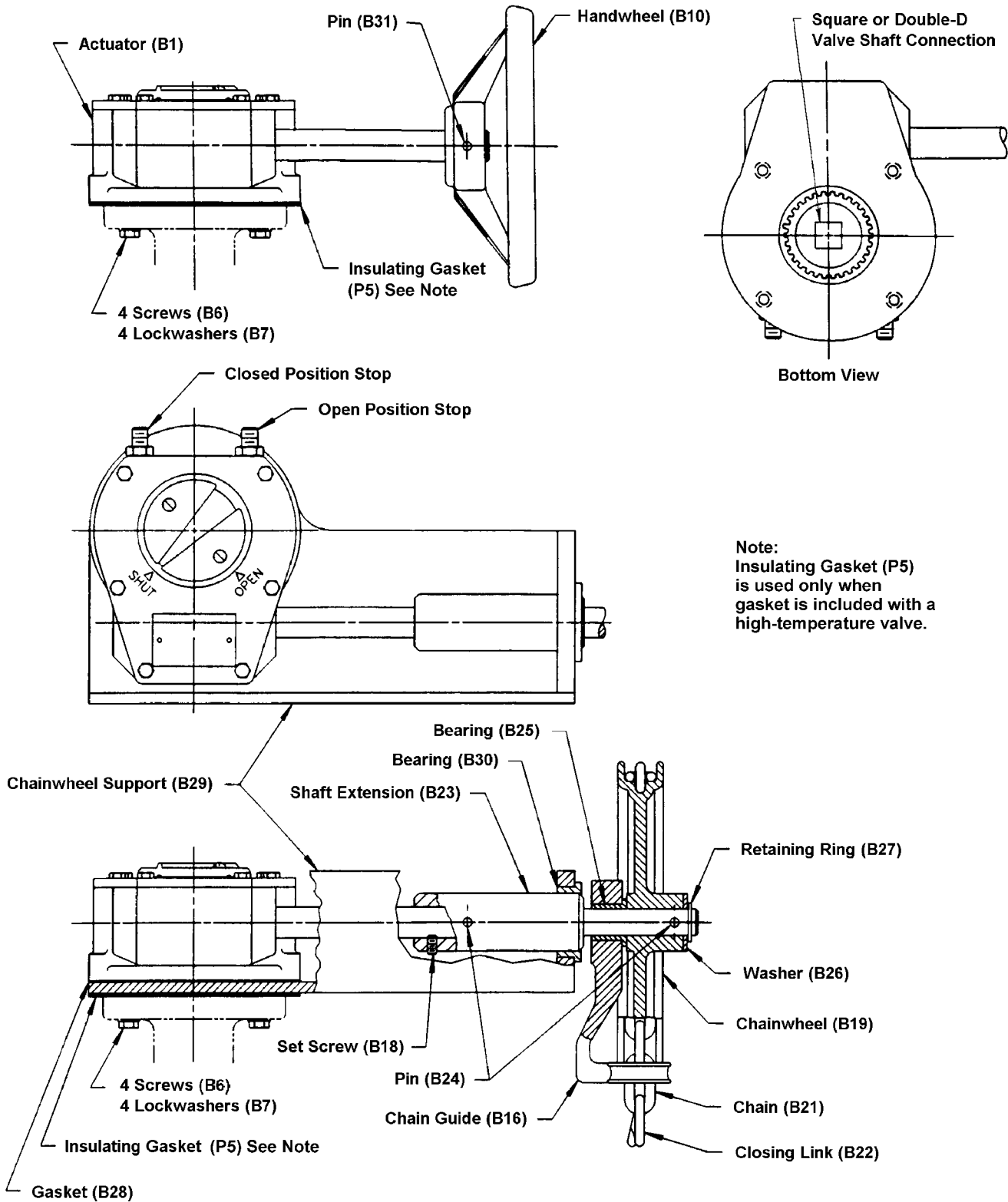

**Figure 1 – Component Identification**

## **Replacing Handwheel with Chainwheel**

The handwheel may be replaced with a chainwheel by following the steps below. Refer to Figure 1 for component identification.

1. Remove the actuator from the valve as described in the Removing Actuator from Valve section.
2. Support the actuator shaft on a solid surface, drive out the handwheel pin (B31), and remove the handwheel (B10).
3. Place the shaft extension (B23) on the actuator shaft, and align the pin holes. Support the shaft extension on a solid surface, and drive the pin (B24) into position.
4. Turn the set screw (B18) into the threaded hole in the shaft extension, and tighten the set screw to  $7 \pm 1$  foot pounds ( $9 \pm 1$  Nm).
5. Some actuators include a splined drive bushing (B2) as indicated in Figure 1. If the actuator includes a bushing, but the bushing has come out of the actuator, note that one large tooth in the bushing is marked with an arrow. Place the bushing in the actuator so that the large tooth is engaged with the deep V-shaped groove in the actuator.
6. With the gasket (B28) in position as shown, place the shaft extension (B23) through the bearing (B30) in the support (B29). Assemble the chain guide (B16) and the chainwheel (B19) onto the shaft extension, and align the pin holes in the shaft extension and the chainwheel. Place the hub of the chainwheel on a solid surface, and drive the pin (B24) into position. Place the washer (B26) on the end of the shaft extension, and then place the retaining clip (B27) in the groove on the end of the shaft extension.
7. Select the desired actuator mounting position. The actuator may be mounted in any one of four positions as indicated on the installation drawing for the valve. With the actuator and the valve in the closed position, engage the actuator with the valve shaft and slide the actuator (B1), gasket (B28), and support (B29) into position on the top of the valve. Fasten the four mounting screws (B6) and lockwashers (B7). Tighten the screws as shown in Table A.

Note: All chainwheel actuators include and use a 1/32" (0.8 mm) thick gasket (B28) between the actuator and the chainwheel support (B29). Handwheel actuators do not include a gasket. However, with high-temperature valves, a 1/16" (1.6 mm) thick insulating gasket (P5) is used on handwheel actuators, and is added under the chainwheel support on chainwheel actuators. The insulating gasket is used only when the gasket is included with the valve.

8. Adjust the open and closed position stops as shown in the Adjustments section.

### **Replacing Chainwheel with Handwheel**

The chainwheel may be replaced with a handwheel by following the steps below. Refer to Figure 1 for component identification.

1. Remove the actuator from the valve as described in the Removing Actuator from Valve section.
2. Loosen the set screw (B18), and drive out the pin (B24). Remove the support (B29) and the shaft extension (B23)—including the chain guide (B16) and the chainwheel (B19)—from the actuator.
3. Place the handwheel (B10) on the actuator shaft. Align the pin holes, support the actuator shaft on a solid surface, and drive the pin (B31) into position.
4. Replace the actuator on the valve as described in the Replacing Actuator on Valve section.

### **Changing Actuator Mounting Position On Valve**

Before changing the actuator mounting position, check to assure that dimensional clearance is available for the proposed actuator location. The actuator may be mounted in any one of four positions as indicated on the Installation Drawing for the valve. To change the position, follow the steps in the Removing Actuator from Valve section and in the Replacing Actuator on Valve section.

### **Lockout Device**

The handwheel actuator is available with an optional lockout accessory that allows the handwheel to be locked with a padlock at any 1/8-turn increment. The actuator may be ordered with the lockout included, or the lockout may be ordered separately as a kit and added as described below. A padlock is not included with the lockout accessory.

#### ***Adding Lockout to MG-30 Actuator***

Refer to Figure 2 and follow the steps below to assemble a lockout kit to an MG-30 Handwheel Actuator.

1. Remove the handwheel pin (B31), and remove the handwheel (B10) from the handwheel shaft.
2. Note the drilled hole in the side of the actuator next to the shaft. Drive the pin (X3) into the hole so that the pin is bottomed out in the hole.
3. With the hub side of the housing flange (X1) facing the actuator, slide the flange onto the shaft so that the hole in the flange is aligned with the pin (X3) in the actuator. Carefully drive the flange onto the pin until the flange hub is against the side of the actuator.
4. With the flat side of the shaft flange (X2) facing the actuator, slide the flange onto the shaft so that there is about 1/16" (1.6 mm) clearance between the flat sides of the two flanges. Hold the shaft flange in that position, and drill a 3/16" (4.76 mm) diameter hole through the boss in the flange hub and through the actuator shaft. Do not drill through the other side of the flange hub. Drive the shaft pin (X5) through the hole in the flange hub and into the hole in the shaft so that the pin is approximately flush with the flange hub.
5. Place the handwheel (B10) in the original position on the handwheel shaft, and secure the handwheel with the pin (B31).

**Lockout Device**     **Adding Lockout to Other Actuators**  
*(Continued)*

Refer to Figure 3 and follow the steps below to assemble a lockout kit to an MG-31, MG-46, or MG-64 Handwheel Actuator.

1. Remove the handwheel pin (B31), and remove the handwheel (B10) from the handwheel shaft.
2. Note the two drilled holes in the side of the actuator next to the shaft. Use the holes to mount the bracket (X3) with two self-tapping screws.
3. Drill a 1/4" (6.35 mm) diameter hole in one side of the hub of the shaft flange (X2). With the hub side of the shaft flange facing the actuator, slide the flange onto the shaft so that there is about 1/16" (1.5 mm) clearance between the flange and the bracket. Hold the shaft flange in that position; use the 1/4" (6.35 mm) hole in the hub as a template, and drill a 7/32" (5.56 mm) diameter hole through the actuator shaft. Do not drill through the other side of the flange hub. Mount the flange to the shaft with the self-tapping screw (X6).
4. Place the handwheel (B10) in the original position on the handwheel shaft, and secure the handwheel with the pin (B31).

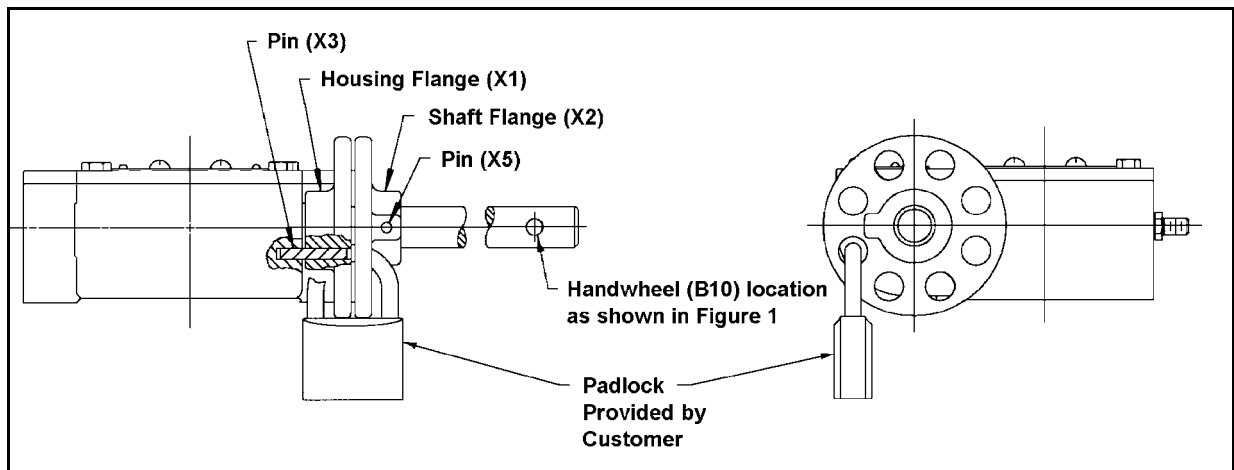

**Figure 2—Lockout on MG-30 Handwheel Actuator**

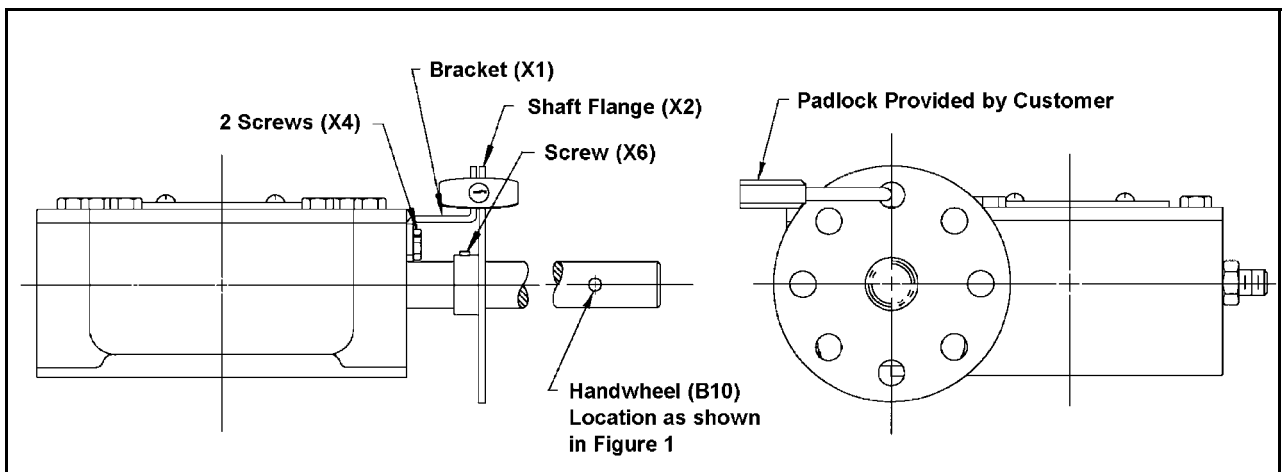

**Figure 3—Lockout on MG-31, MG-46, or MG-64 Handwheel Actuator**

# DeZURIK

## Mastergear Manual Actuator

---

### Troubleshooting

<b>Condition</b>	<b>Possible Cause</b>	<b>Corrective Action</b>
Actuator closes to wrong position.	Closed position stop is set incorrectly.	Adjust closed position stop. See ADJUSTMENTS section.
Actuator opens to wrong position.	Open position stop is set incorrectly.	Adjust open position stop. See ADJUSTMENTS section.
Actuator will not fully operate valve.	Pipeline obstruction in valve is preventing closure.	Remove obstruction.