

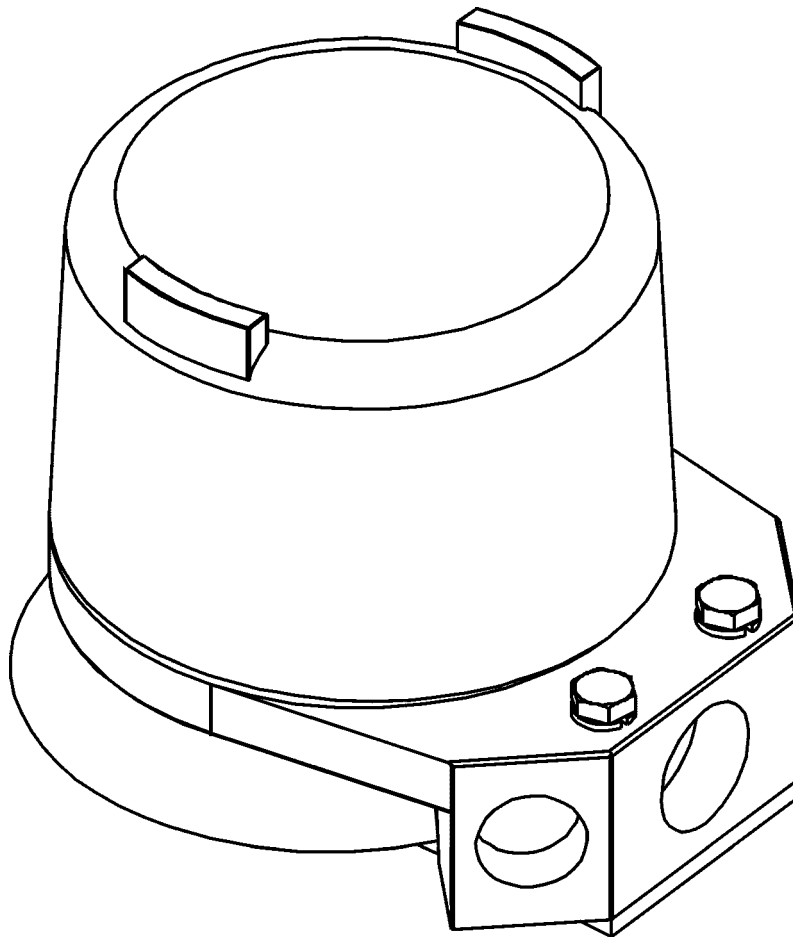

SWITCH AND POSITION TRANSMITTER



Instruction **D10350**
August 2009

DeZURIK

Switch and Position Transmitter

Instructions

These instructions provide information about Switch and Position Transmitters. They are for use by personnel who are responsible for installation, operation and maintenance of Switch and Position Transmitters.

Safety Messages

All safety messages in the instructions are flagged with an exclamation symbol and the word Caution, Warning or Danger. These messages indicate procedures that must be followed exactly to avoid equipment damage, personal injury or death. Safety label(s) on the product indicate hazards that can cause equipment damage, personal injury or death. If a safety label becomes difficult to see or read, or if a label has been removed, please contact DeZURIK for replacement label(s).



WARNING!

Personnel involved in the installation or maintenance of valves should be constantly alert to potential emission of pipeline material and take appropriate safety precautions. Always wear suitable protection when dealing with hazardous pipeline materials. Handle valves, which have been removed from service with suitable protection for any potential pipeline material in the valve.

Inspection

Your Switch and Position Transmitter has been packaged to provide protection during shipment, however, it can be damaged in transport. Carefully inspect the unit for damage upon arrival and file a claim with the carrier if damage is apparent.

Parts

Recommended spare parts are listed on the assembly drawing. These parts should be stocked to minimize downtime.

Order parts from your DeZURIK sales representative, or directly from DeZURIK. When ordering parts, please include the 7-digit part number and 4-digit revision number (example: **9999999R000**) located on the data plate attached to the valve assembly. Also include the part name, the assembly drawing number, the balloon number and the quantity stated on the assembly drawing.

DeZURIK Service

DeZURIK service personnel are available to install, maintain and repair all DeZURIK products. DeZURIK also offers customized training programs and consultation services.

For more information, contact your local DeZURIK sales representative or visit our website at www.dezurik.com.

Table of Contents

Description - - - - -	4
Electrical Connections - - - - -	4
Mechanical Switches - - - - -	4
Proximity Switches - - - - -	5
Position Transmitter - - - - -	6
Indicator Adjustment - - - - -	7
Switch Mounting Kit used on PMV Positioner - - - - -	8

DeZURIK

Switch and Position Transmitter

Description

This valve accessory provides electrical functions in response to the open, closed, and intermediate positions of a 2-way valve or a 2-position 3-way valve. Electrical switching and variable current functions are provided in selected combinations. The adjustable sensing devices are mechanically linked to a valve, a valve actuator, or a positioner.

Components are located in a sealed and accessible aluminum enclosure, constructed to comply with NEMA types 4, 4X, 7 and 9. The position of the valve is visibly displayed in two windows at 180° viewing angles. Three basic options consisting of mechanical switches, proximity switches, and a position transmitter are provided individually or in selected combinations. The three options are described below.

Electrical Connections

Field wiring enters through 3/4" and 1/2" NPT electrical connections to a prewired and labeled terminal strip as described in the following sections. One 1/2" pipe plug is provided with the unit. If the 1/2" connection is not used, install the pipe plug tightly in the connection. Do not use thread sealant.

Mechanical Switches

The two SPDT or four SPDT mechanical snap-acting switches each have a rating of:

- Silver Contacts -10 Amps at 125/250 VAC, or 0.5 Amp at 125 VDC.
- Gold Contacts - 1 Amp at 125 VAC, or 0.5 Amp at 30 VDC

With two SPDT switches, the top switch is factory set to trip as the valve reaches the closed or clockwise position, and the bottom switch is factory set to trip as the valve reaches the open or counterclockwise position. The internal wiring from the switches to the terminal strip is shown in Figure 1.

With four SPDT switches, the top (first) switch is factory set to trip as the valve reaches the closed or clockwise position, and the bottom (fourth) switch is factory set to trip as the valve reaches the open or counterclockwise position. The second and third switches are not factory set, but may be set in the field. The internal wiring from the switches to the terminal strip is shown in Figure 2.

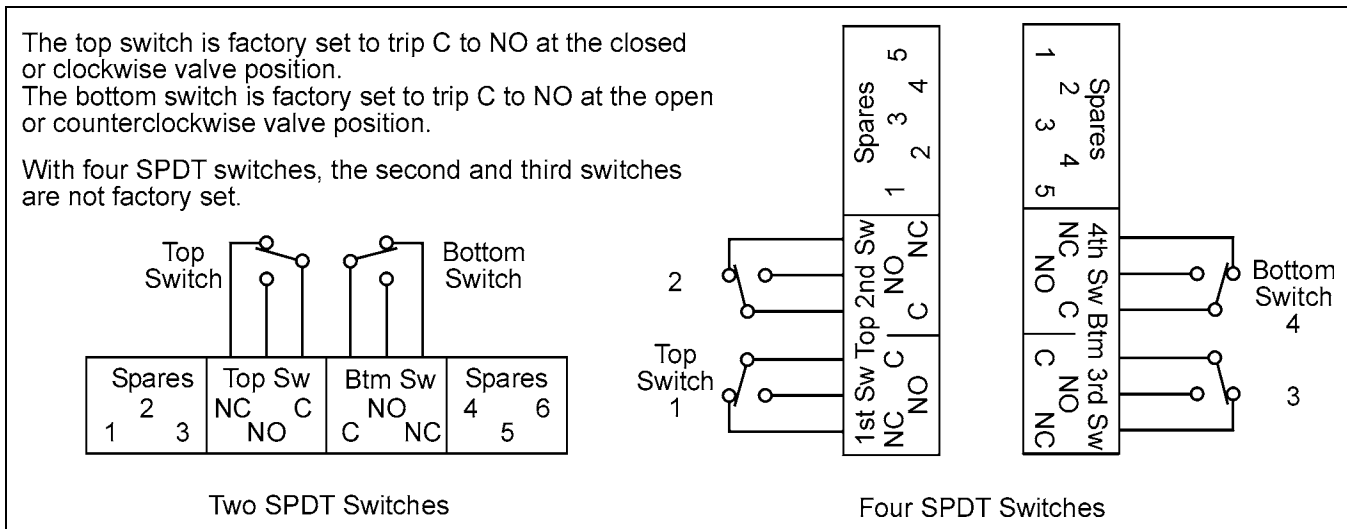

Figure 1— Mechanical Switches

Mechanical Switches *(Continued)*

Each switch is actuated by a rotating cam. To adjust a top switch, push the top cam down, rotate it to the desired position, and release the cam so it engages into the new position on the spline. To adjust a bottom switch, repeat the process with the bottom cam, but lift the cam upwards to rotate it to the desired position. Each cam may be further fine-tuned between spline positions by turning the set screw on the cam with a 1/16" hex driver. The set screw is limited to adjustment of no more than one full turn.

Proximity Switches

The two SPDT proximity switches each has a rating of 0.3 amp at 120 VAC, or 0.2 amp at 30 VDC. The switch contacts are sealed for low-energy switching of solid-state signal circuits.

The top switch is factory set to trip as the valve reaches the closed or clockwise position, and the bottom switch is factory set to trip as the valve reaches the open or counterclockwise position. The internal wiring from the switches to the terminal strip is shown in Figure 2.

Each switch is actuated as the white stripe on its rotating cam aligns with the white stripe on the switch. To adjust the top switch, push the top cam down, rotate it to the desired position, and release the cam so it slides into the new position on the spline. To adjust the bottom switch, repeat the process with the bottom cam, but lift the cam upwards to rotate it to the desired position.

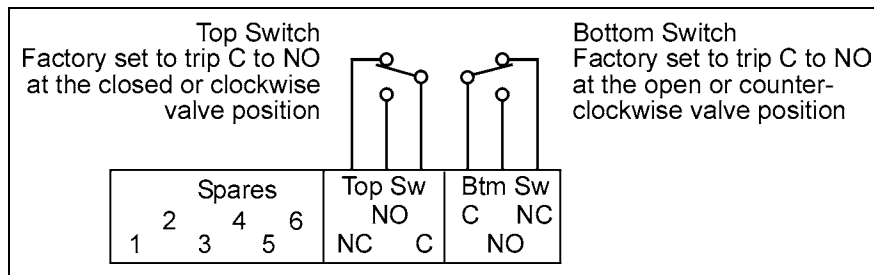

Figure 2—Proximity Switches

Position Transmitter

The position transmitter provides a 4 to 20 mA output signal with the plus and minus terminals connected in series with an external 24 VDC power supply. Voltage variations from 10 VDC to 40 VDC do not affect the current signal. The maximum load is 700 ohms at 24 VDC. The unit is calibrated as shown in the following steps. Refer to Figure 3 for component identification.

1. Plug the 3-pin potentiometer connector into the appropriate 3 pins on the 5-pin block as described in Figure 3. The 5-pin block is located next to the span adjustment.
2. Place the valve in the position desired for 4 mA output. Do not connect power until step 4. If the valve is in the closed or clockwise position, connect an ohmmeter to terminals 2 and 3 of the potentiometer; if the valve is in the open or counterclockwise position, connect an ohmmeter to terminals 1 and 2 of the potentiometer.
3. Loosen the coupling that drives the potentiometer shaft, and rotate the potentiometer so that the ohmmeter reads 500 ± 100 ohms. Then tighten the coupling, and disconnect the ohmmeter from the potentiometer.
4. Connect a 20 mA ammeter and a 24 VDC power supply to terminals + and – as shown in Figure 3.
5. Adjust the zero trimpot so that the ammeter reads 4 ± 0.1 mA.
6. Place the valve in the position desired for 20 mA output. Adjust the span trimpot so that the ammeter reads 20 ± 0.1 mA. The zero and span adjustments are not interactive.

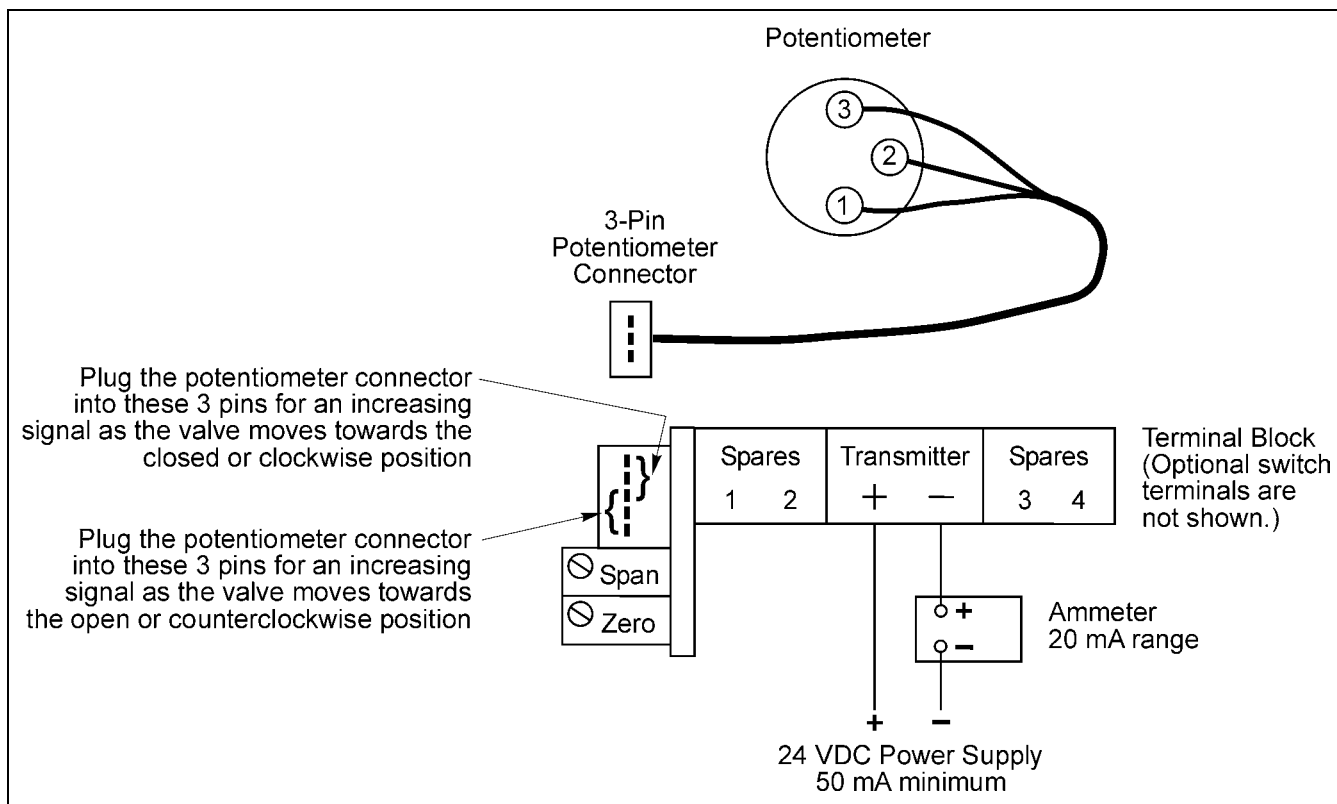

Figure 3—Position Transmitter

Indicator Adjustment

The open-closed indicator on all units, shown in Figure 4 as indicator drum (A4), may be re-indexed on the input shaft as follows:

1. Remove the two mounting screws and washers near the conduit connection, and lift the unit from position so that the bottom of the unit is accessible.
2. Loosen the screw (A5) about 3 turns.
3. Pull out the spacer (A6) and shaft adaptor (A1) so that the spacer pins are disengaged from the timing holes in the indicator drum (A4). (The shaft adaptor may be a different size and/or shape than shown in Figure 3.)
4. Rotate the indicator drum (A4) to the desired position, and push the shaft adaptor (A1) and spacer (A6) towards the indicator drum (A4) to engage the spacer pins with the nearest timing holes in the indicator drum. Tighten the screw (A5) to 8 ± 2 inch pounds.
5. Replace the unit in the same mounting position with the two screws and washers, and tighten the screws to 80 ± 5 inch pounds.
6. To fine-tune the position of the indicator cover (A3), loosen the set screw (A2), and rotate the indicator cover to the desired position. Tighten the set screw.

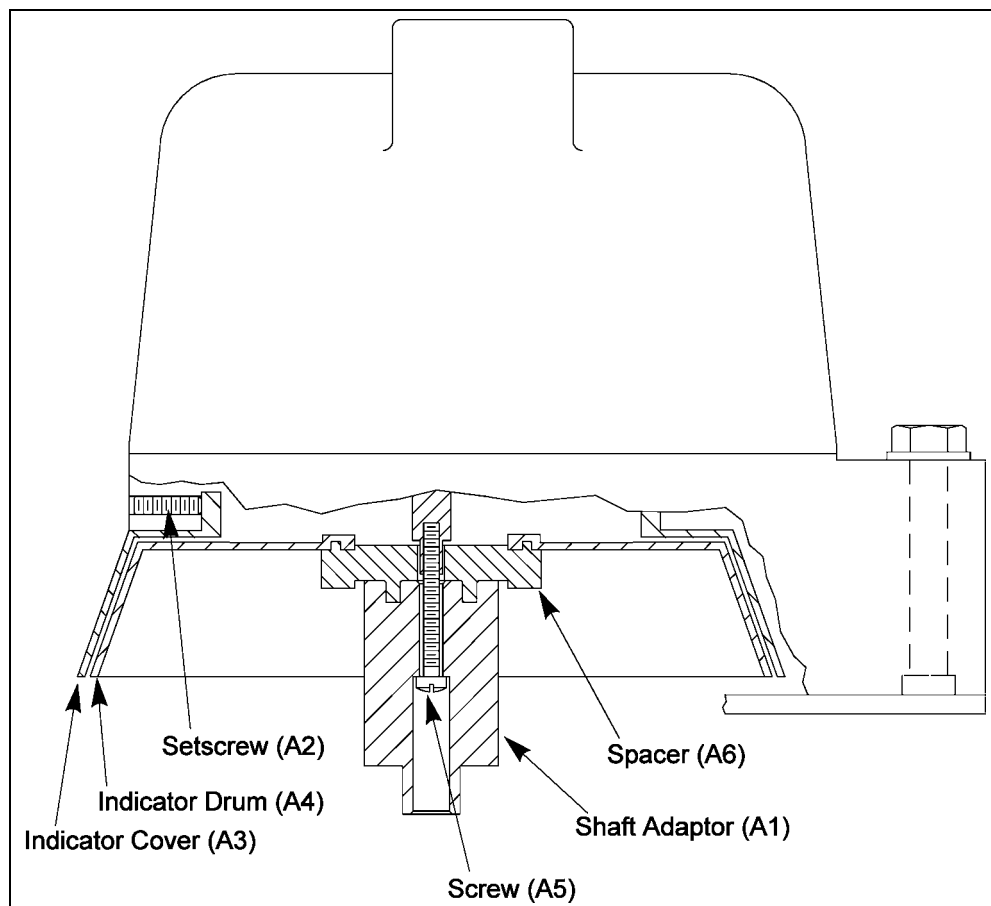

Figure 4 - Indicator Adjustment Components

Switch Mounting Kit used on PMV Positioner

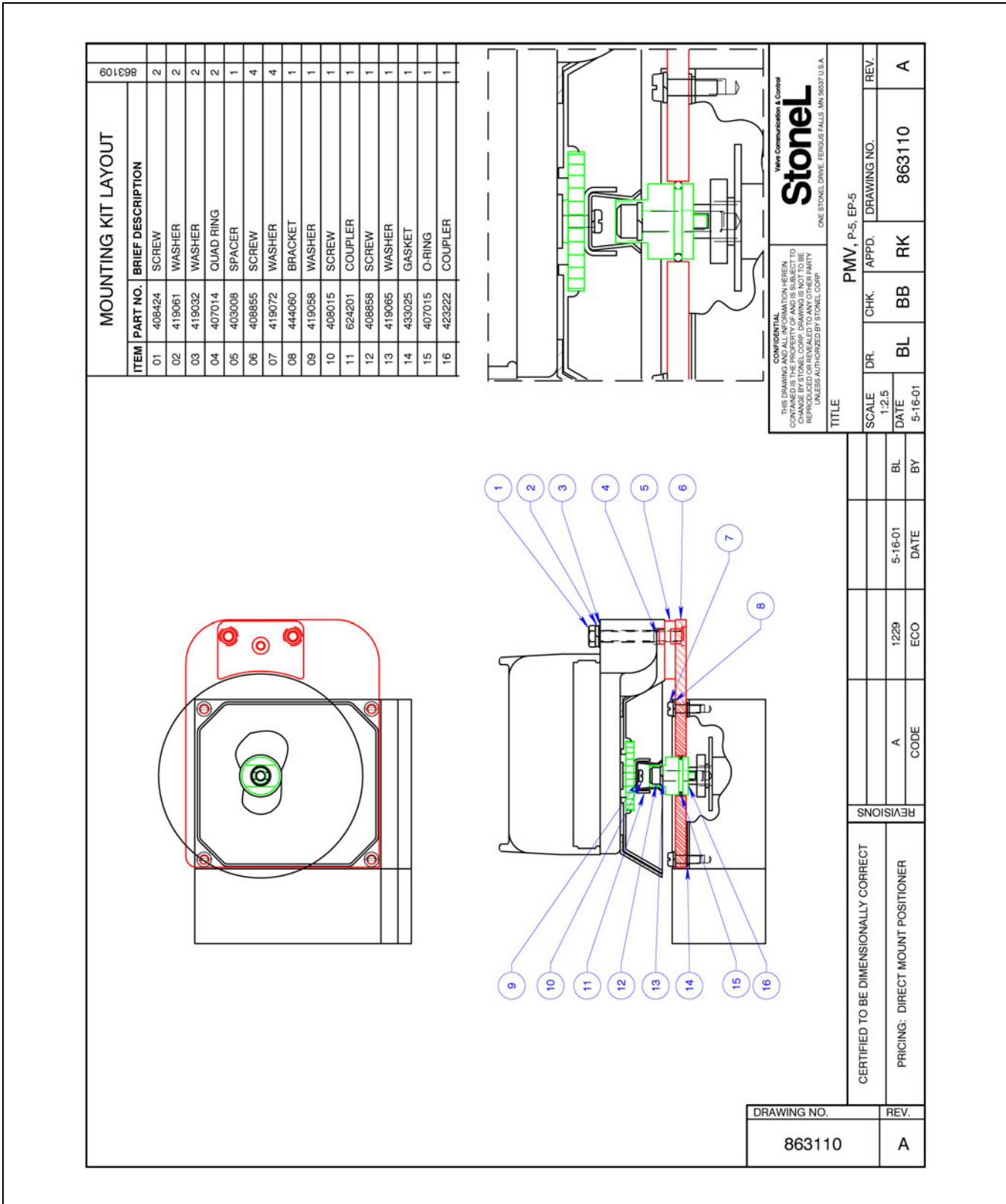

Figure 5 – Switch Mounting Kit used on PMV Positioner