

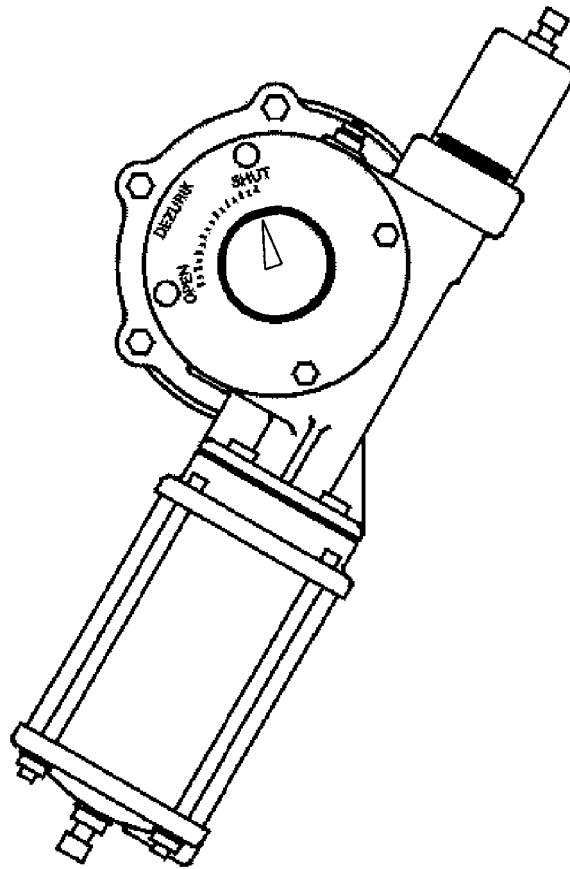

# CYLINDER OPERATED G-SERIES ACTUATOR USED ON BUTTERFLY VALVES



Instruction D10082  
March 2010

# DeZURIK

## Cylinder Operated G-Series Actuator

---

### Instructions

These instructions provide information about G-Series Cylinder Actuators. They are for use by personnel who are responsible for installation, operation and maintenance of G-Series Cylinder Actuators.

### Safety Messages

All safety messages in the instructions are flagged with an exclamation symbol and the word Caution, Warning or Danger. These messages indicate procedures that must be followed exactly to avoid equipment damage, personal injury or death. Safety label(s) on the product indicate hazards that can cause equipment damage, personal injury or death. If a safety label becomes difficult to see or read, or if a label has been removed, please contact DeZURIK for replacement label(s).



#### **WARNING!**

**Personnel involved in the installation or maintenance of valves should be constantly alert to potential emission of pipeline material and take appropriate safety precautions. Always wear suitable protection when dealing with hazardous pipeline materials. Handle valves, which have been removed from service with the assumption of pipeline material within the valve.**

---

### Inspection

Your G-Series Cylinder Actuator has been packaged to provide protection during shipment; however, it can be damaged in transport. Carefully inspect the unit for damage upon arrival and file a claim with the carrier if damage is apparent.

### Parts

Recommended spare parts are listed on the assembly drawing. These parts should be stocked to minimize downtime.

Order parts from your local DeZURIK sales representative, or directly from DeZURIK. When ordering parts, please include the 7-digit part number and 4-digit revision number (example: **9999999R000**) located on the data plate attached to the valve assembly. Also include the part name, the assembly drawing number, the balloon number and the quantity stated on the assembly drawing.

### DeZURIK Service

DeZURIK service personnel are available to install, maintain and repair all DeZURIK products. DeZURIK also offers customized training programs and consultation services.

For more information, contact your local DeZURIK sales representative or visit our website at [www.dezurik.com](http://www.dezurik.com).

## Table of Contents

Description - - - - -	4
Air Supply - - - - -	4
Lubrication - - - - -	4
Actuator Identification - - - - -	4
Position Stops - - - - -	5
Stop Adjustments - - - - -	5
Closed Stop Adjustment - - - - -	5
Removing Actuator - - - - -	6
Installing Actuator - - - - -	6
Removing Cylinder - - - - -	6
Installing Cylinder - - - - -	7
Disassembling Actuator - - - - -	7
Reassembling Actuator - - - - -	8
Changing Mounting Positions - - - - -	10
Troubleshooting - - - - -	11

# DeZURIK

## Cylinder Operated G-Series Actuator

### Description

The G-Series Cylinder Actuator is a totally enclosed, quarter turn, pneumatic operated actuator. A 2" (50mm) square nut on top of the actuator is provided for manual operation.

**Note:** Tapered Plug valves equipped with cylinder actuators do not provide dead-tight shutoff.

### Air Supply

The supply pressure to the cylinder should be between 50 and 100 psi (344 and 689 kPa).

### Lubrication

The G-Series Cylinder Actuator has been lubricated at the factory and requires no routine lubrication. If the actuator is disassembled, lubricate the rack, rack guide, gear sector and bearings using one of these lubricants:

- Keystone Zeniplex-1 (**recommended**)
- Amoco Amolith Grease #1-EP (alternate)
- Amsoil GHD (alternate)
- Mobil Mobilux EP 1 (alternate)
- Petro-Canada Vultrex MPG EP 1 (alternate)
- Shell Alvania EP 1 (alternate)
- Texaco Multifak EP 1 (alternate)

If the cylinder is disassembled, it must be lubricated as described in the cylinder instructions.

### Actuator Identification

The G-Series Cylinder Actuator is available in two sizes: G12 and G16. See Figure 1 for actuator identification.

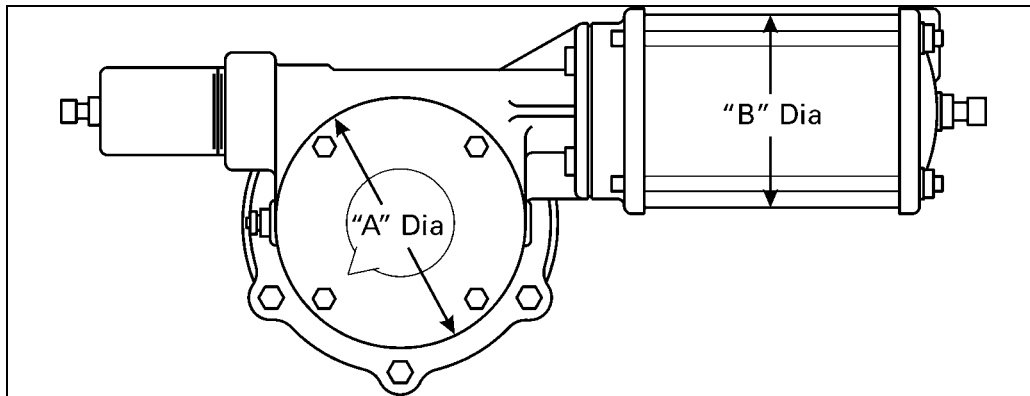

**Figure 1 - Actuator Identification**

To determine the actuator size, measure the diameter of the cover - see Figure 1 and Table A. To determine the cylinder size, measure the diameter of the cylinder - see Figure 1 and Table B.

**Table A: Actuator Identification**

Actuator	Ø "A"	
	IN	MM
G12	15	390
G16	19	485

**Table B: Cylinder Identification**

Cylinder	Ø "B"	
	IN	MM
C8	8.5	215
C10	10.5	265
C12	12.5	315
C14	14.5	365

## Position Stops

Valves equipped with cylinder operated G-Series actuators have stops to limit valve travel in both the clockwise and counterclockwise directions. See the *STOP ADJUSTMENTS* section of this instruction for details on adjusting the stops.

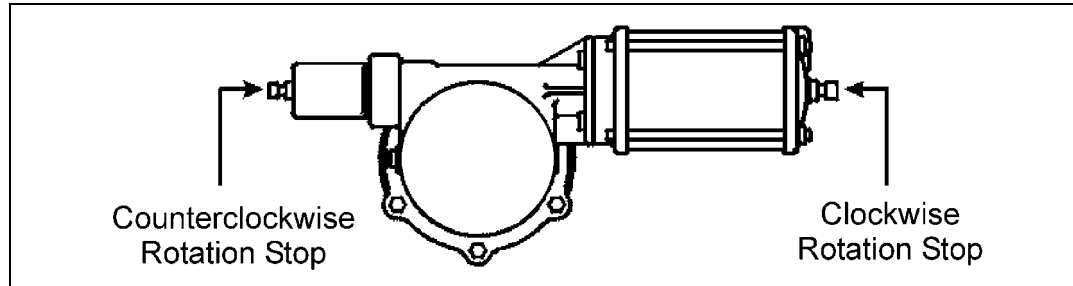

**Figure 2 – Position Stops**

The position stops are factory set and do not require adjustment unless the actuator has been disassembled or actuator orientation has been changed.

## Stop Adjustments

Clockwise rotation of the disc is stopped when the piston rod contacts the set screw in the cylinder cap.

Counterclockwise rotation of the disc is stopped when the end of the rack rod contacts the set screw in the end of the extension cap.

To adjust the stops, follow these steps:

1. Actuate the valve to determine the need for stop adjustment.



### **WARNING!**

Accidental operation of power actuator can cause personal injury or equipment damage. Disconnect and lock out power to actuator before servicing.

2. If adjustment is required, loosen the lock nut on the stop to be adjusted and turn the stop in or out as required. Tighten the lock nut.
3. Actuate the valve to check the stop adjustment and repeat Steps 2 and 3 until the desired stop setting is achieved.

## Closed Stop Adjustment

1. Open the valve.
2. Loosen the jam nut on the closed stop adjusting screw, then back the adjusting screw out about 1-1/2 inches.
3. Apply air pressure to the cylinder port closest to the actuator housing until the valve is in the closed position. The correct closed position for your type of valve is described in the Valve Instruction.
4. After the valve is in the closed position, turn the stop adjusting screw in just until resistance is felt as it contacts the piston in the cylinder.
5. Make sure the thread seal is intact, and then lock the adjusting screw in this position by tightening the jam nut against the actuator.

### Removing Actuator

1. Discontinue flow, relieve pipeline pressure and close valve.



#### **WARNING!**

Accidental operation of power actuator can cause personal injury or equipment damage. Disconnect and lock out power to actuator before servicing.

---

2. Place the valve in the closed position.
3. Disconnect and lock out the pneumatic power to prevent accidental operation of the actuator.
4. Scribe a line on the valve and actuator to be used for alignment during actuator installation.
5. Remove the screws fastening the actuator adaptor to the valve or adaptor plate.
6. Lift the actuator off the valve. Be careful not to lose the actuator drive key.

### Installing Actuator

1. Place the valve in the closed position.
2. Place the actuator drive key in the keyseat in the valve shaft.
3. Line up the scribe marks made during actuator removal, then set the actuator on the valve so the valve shaft slides into the actuator gear sector. Fasten the actuator adaptor to the valve or adaptor plate with the screws.
4. Connect the supply air tubing to the actuator.
5. Pipeline pressure and flow may now be restored.

### Removing Cylinder

This procedure can be performed with the actuator installed on the valve or removed.

1. Discontinue flow and relieve pipeline pressure.
2. Apply air pressure to the port in the cylinder cap (the end farthest from the actuator housing) until the valve has moved to the end of its stroke.



#### **WARNING!**

Accidental operation of power actuator can cause personal injury or equipment damage. Disconnect and lock out power to actuator before servicing.

---

3. Disconnect and lock out the pneumatic power to prevent accidental operation of the actuator.
4. Disconnect the tubing from both cylinder ports.
5. Remove the extension cap from the actuator housing opposite the cylinder. On The G12 actuators, the cap is screwed on; on the G16 actuators, the cap is held on with four screws.
6. After the extension cap is removed, remove the two nuts from the end of the rack rod.
7. Remove the four screws that fasten the cylinder or cylinder adaptor to the actuator housing.
8. Carefully remove the cylinder by sliding it away from the actuator until the rack rod clears the actuator housing.
9. See the Cylinder instructions for details on rebuilding the cylinder.

## Installing Cylinder

1. Scrape the old gasket material from the actuator housing and cylinder head, and then place a new gasket on the cylinder head.
2. Install the cylinder/rack rod assembly by sliding the rack rod through the rack; then fasten the cylinder to the housing.

Note: The cylinder mounting flange on the actuator housing is stamped with the letter "P."

If the rack rod is not attached to the cylinder, clean the threads of both the rack rod and the cylinder shaft, then apply Loctite to the cylinder shaft threads, and screw the rack rod onto the cylinder shaft until tight.

3. Screw one nut onto the rack rod until it is tight against the rack.
4. Screw the other nut onto the rack rod and tighten the two nuts against one another.
5. Install the extension cap onto the actuator housing.
6. Connect the supply pressure tubing to the cylinder.
7. Turn on the supply air to the cylinder.
8. Check the actuator stop settings and readjust if necessary. The correct adjustment procedure is described in the STOP ADJUSTMENT Section of this Instruction.
9. Pipeline flow may now be restored.

## Disassembling Actuator

1. Discontinue flow and relieve pipeline pressure.



### **WARNING!**

Accidental operation of power actuator can cause personal injury or equipment damage. Disconnect and lock out power to actuator before servicing.

---

2. Apply air pressure to the port in the cylinder cap (the end farthest from the actuator housing) until the valve has moved to the end of its stroke.
3. Disconnect and lock out the pneumatic, hydraulic, or electrical power to prevent accidental operation of the actuator.
4. Scribe corresponding lines on the valve and actuator to help align them during installation.
5. Note the position of the pointer, and then remove the pointer screws and pointer.
6. Scribe corresponding lines on the actuator cover and housing, then remove the cover screws and cover from the top of the actuator.

**Note:** It may be necessary to drive a chisel between the cover and actuator housing to loosen the cover.

### Disassembling Actuator *(Continued)*

7. Mark the teeth of the rack and gear as shown in Figure 3 and lift the gear sector out of the actuator; be careful not to lose the actuator drive key.
8. Remove the nuts from the end of the rack rod.
9. Remove the screws or nuts fastening the cylinder assembly to the housing and carefully remove the cylinder assembly by sliding it away from the actuator until the rack rod clears the actuator housing.
10. Remove the rack from the housing.
11. Remove the rack bearing (if noticeable wear to bearing) by prying it from the actuator housing.
12. Scribe corresponding lines on the valve and adapter to be used for alignment during actuator reassembly.
13. Remove the screws fastening the adapter to the valve, and then lift the actuator and adaptor off the valve.
14. Lift the rest of the actuator and the adapter off the valve.

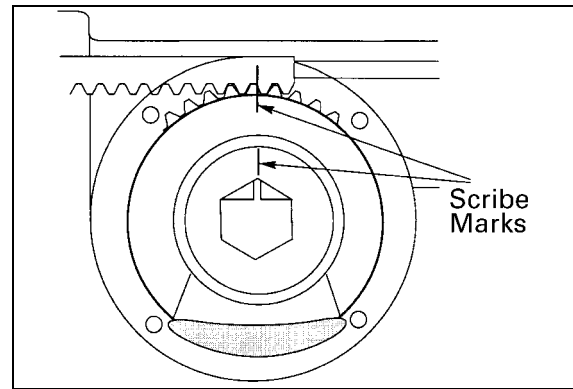

**Figure 3 – Scribe Marks**

### Reassembling Actuator

Install new bearings and seals in the adapter and cover if necessary. See Figure 4 for proper placement.

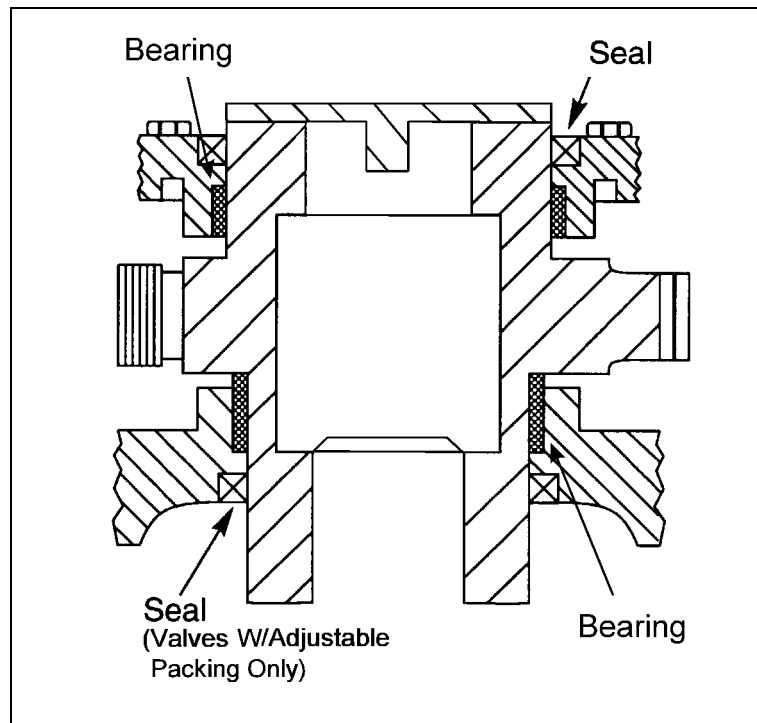

**Figure 4 – Location of Actuator Seals and Bearings**

**Reassembling Actuator** *(Continued)*

1. Line up the scribe marks on the valve and adapter made during actuator removal; then set the adapter and housing on the valve.
2. Fasten the adapter to the valve.
3. Insert the rack bearing on the pin in the actuator housing (if replacing worn bearing).
4. Apply a liberal amount of grease to the rack teeth and the back of the rack that will contact the rack bearing; then install the rack in the housing.
5. Place the actuator drive key in the keyseat in the valve shaft.
6. Apply a liberal amount of grease to the gear sector teeth and a light amount of grease to the journals; then place the gear sector in the housing and carefully align the teeth as marked during disassembly.

**Note:** It may be necessary to loosen the adapter mounting screws and move the housing a small amount to align the gear. Be sure to retighten the mounting screws after aligning the gear.

7. Scrape the old gasket material from the actuator housing and cylinder head, then place a new gasket on the cylinder head.
8. Install the cylinder/rack rod assembly by sliding the rack rod through the rack then fasten the cylinder to the housing.

**Note:** If the rack rod is not attached to the cylinder, clean the threads of both the rack rod and the cylinder shaft, then apply Loctite to the cylinder shaft threads and screw the rack rod onto the cylinder shaft until tight.

9. Screw one nut onto the rack rod until it is tight against the rack.
10. Screw the other nut onto the rack rod and tighten the two nuts against one another.
11. Set a new cover gasket on the housing, then install and fasten the top cover on the housing; make sure the scribe marks line up.
12. Fasten the pointer to the top of the gear sector.
13. Replace the extension cap.
14. Check the stop settings and readjust if necessary. The correct adjustment procedure is described in the *STOP ADJUSTMENT* section of this instruction.
15. Pipeline flow may now be restored.

## Changing Mounting Positions

The actuator can be mounted in 90° increments around the valve stem.

1. Discontinue flow and relieve pipeline pressure.



**WARNING!**

Accidental operation of power actuator can cause personal injury or equipment damage. Disconnect and lock out power to actuator before servicing.

---

2. Place the valve in the closed position.
3. Relieve actuator supply pressure, and then disconnect the air supply tubing from the valve assembly.
4. Scribe a line on the valve and actuator. This line will be used for alignment when the actuator is reassembled on the valve.
5. Note the position of the pointer, then remove the pointer screws and pointer.
6. Remove the cover bolts and cover from the actuator.  
**Note:** It may be necessary to drive a chisel between the cover and actuator housing to loosen the cover.
7. Mark the rack and gear teeth to indicate which teeth are engaged so the gear can be reinstalled in the correct orientation.
8. Lift the gear sector out of the actuator; be careful not to lose the actuator drive key.
9. Remove the screws fastening the adaptor to the valve, then lift the actuator and adaptor off the valve.
10. Remove the gear sector seal from the top cover.
11. Scrape the old gasket material from the top cover and actuator housing.
12. Grease the new seal and press it into the top cover.
13. Line up the scribe marks made earlier, then fasten the adaptor to the valve with the six bolts.
14. Place the actuator drive key in the keyseat in the valve shaft.
15. Pack the gear sector teeth with grease and slide the gear sector down the valve shaft, making sure it is in the position noted before removal.
16. Place a new gasket on the actuator housing, then fasten the cover in place.
17. Fasten the pointer to the top of the gear sector.
18. Connect the air supply tubing to the cylinder.
19. Check the stop settings and readjust if necessary. The correct adjustment procedure is described in the *STOP ADJUSTMENT* section of this Instruction.
20. Pipeline flow and pressure may now be restored.

---

## Troubleshooting

<b>Condition</b>	<b>Possible Cause</b>	<b>Corrective Action</b>
Actuator will not fully operate valve	Cylinder pressure is low	Increase cylinder pressure. Do not exceed 100 psi (69 kPa).
	Piston seal in cylinder is leaking	Replace piston seal(s). See Cylinder instructions.
	Pipeline obstruction in valve is preventing closure	Remove obstruction
Actuator rotates wrong direction	Air connections to cylinder are incorrect	Reverse air connections to cylinder