

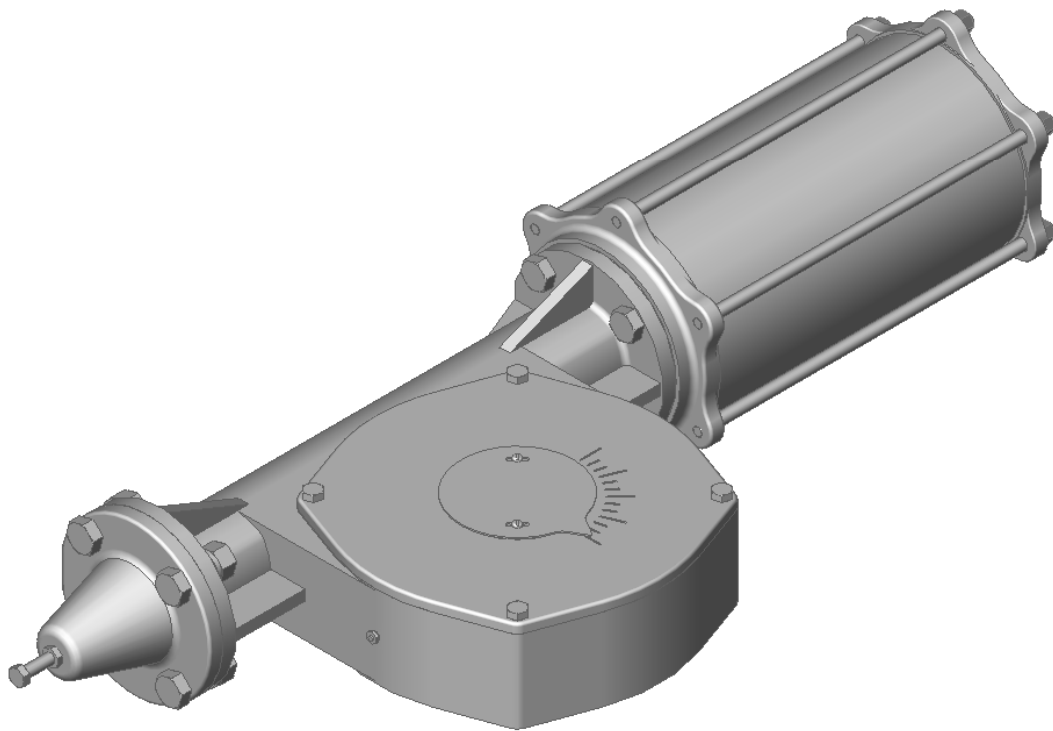

**SPRING RETURN
CYLINDER OPERATOR
FOR G-SERIES ACTUATORS
USED ON PEF 100% PORT ECCENTRIC VALVES**



Instruction **D10466**
March 2009

DeZURIK

Spring Return Cylinder Operator

Instructions

These instructions provide information about Spring Return Cylinder Operators. They are for use by personnel who are responsible for installation, operation and maintenance of Spring Return Cylinder Operators.

Safety Messages

All safety messages in the instructions are flagged with an exclamation symbol and the word Caution, Warning or Danger. These messages indicate procedures that must be followed exactly to avoid equipment damage, personal injury or death. Safety label(s) on the product indicate hazards that can cause equipment damage, personal injury or death. If a safety label becomes difficult to see or read, or if a label has been removed, please contact DeZURIK for replacement label(s).



WARNING!

Personnel involved in the installation or maintenance of valves should be constantly alert to potential emission of pipeline material and take appropriate safety precautions. Always wear suitable protection when dealing with hazardous pipeline materials. Handle valves, which have been removed from service with the assumption of pipeline material within the valve.

Inspection

Your Spring Return Cylinder Operator has been packaged to provide protection during shipment; however, it can be damaged in transport. Carefully inspect the unit for damage upon arrival and file a claim with the carrier if damage is apparent.

Parts

Recommended spare parts are listed on the assembly drawing. These parts should be stocked to minimize downtime.

Order parts from your local DeZURIK sales representative, or directly from DeZURIK. When ordering parts, please include the 7-digit part number and 4-digit revision number (example: **9999999R000**) located on the data plate attached to the valve assembly. Also include the part name, the assembly drawing number, the balloon number and the quantity stated on the assembly drawing.

DeZURIK Service

DeZURIK service personnel are available to install, maintain and repair all DeZURIK products. DeZURIK also offers customized training programs and consultation services.

For more information, contact your local DeZURIK sales representative or visit our website at www.dezurik.com.

Table of Contents

Description - - - - -	4
Air Supply - - - - -	4
Lubrication - - - - -	4
Parts Identification - - - - -	4
Cylinder Inspection Procedure - - - - -	5
Cylinder Disassembly - - - - -	7
Cylinder Reassembly - - - - -	8
Stop Adjustments	
<i>Cylinder mounted for Spring-to-Close: Open Position Stop</i> - - - - -	10
<i>Cylinder mounted for Spring-to-Close: Closed Position Stop</i> - - - - -	10
<i>Cylinder mounted for Spring-to-Open: Open Position Stop</i> - - - - -	10
<i>Cylinder mounted for Spring-to-Open: Closed Position Stop</i> - - - - -	10
Changing the Action - - - - -	13
<i>Section A: From Spring-to-Close to Spring-to-Open</i> - - - - -	14
<i>Section B: From Spring-to-Open to Spring-to-Close</i> - - - - -	15
Removing Cylinder - - - - -	19

DeZURIK

Spring Return Cylinder Operator

Description

This is a Spring Return Cylinder Operator intended for pneumatic service.



WARNING!

This is a pressure containing vessel. Release the pressure from the cylinder before attempting any disassembly or repair.

This vessel also contains a compressed spring; the potential for personal injury exists during disassembly. For safe disassembly, follow these instructions carefully.

Air Supply

Maximum cylinder supply pressure is 100 psi (689 kPa). For maximum cylinder life, the air should be filtered and dry.

Lubrication

If the cylinder is disassembled, lubricate the cylinder wall, piston seal, O-ring and O-ring groove using one of these lubricants:

- Dow Corning Molykote No. 44 (**recommended**)
- Shell Retinax AM (alternate)
- Shell Lithall MDS (alternate)

Parts Identification

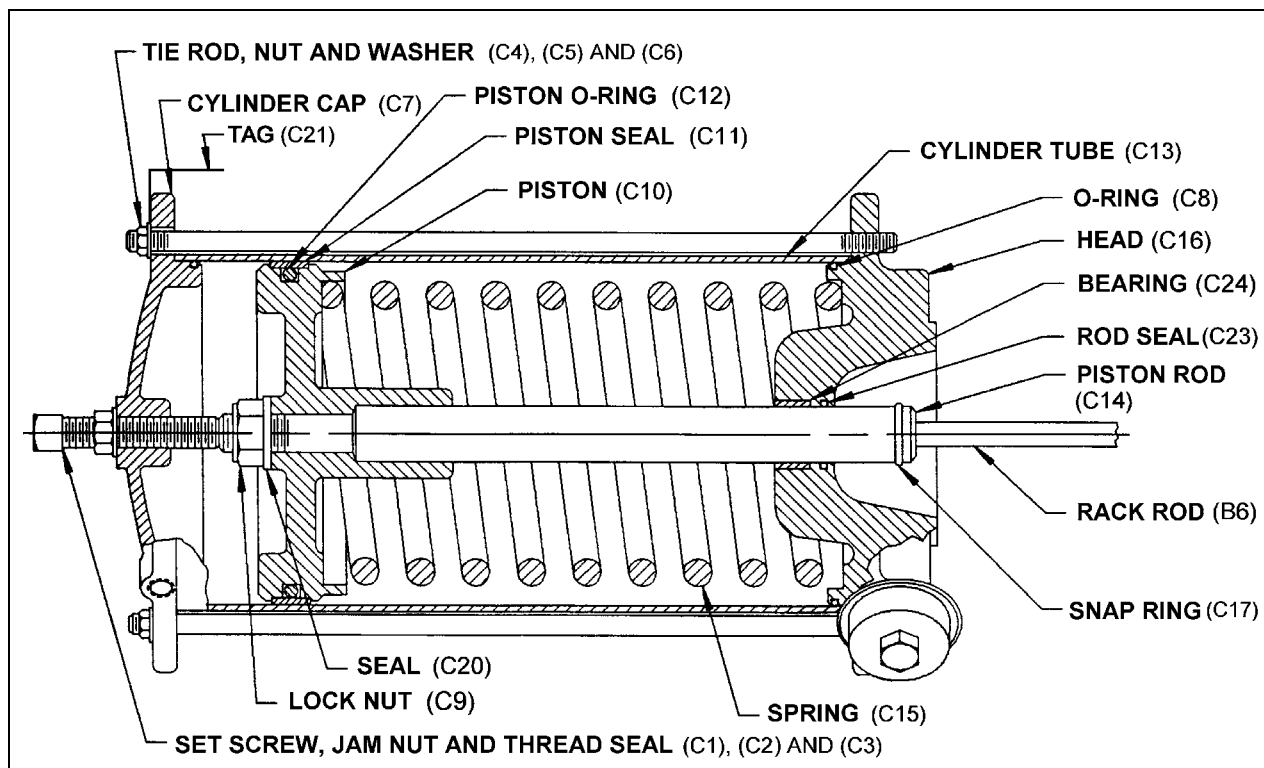
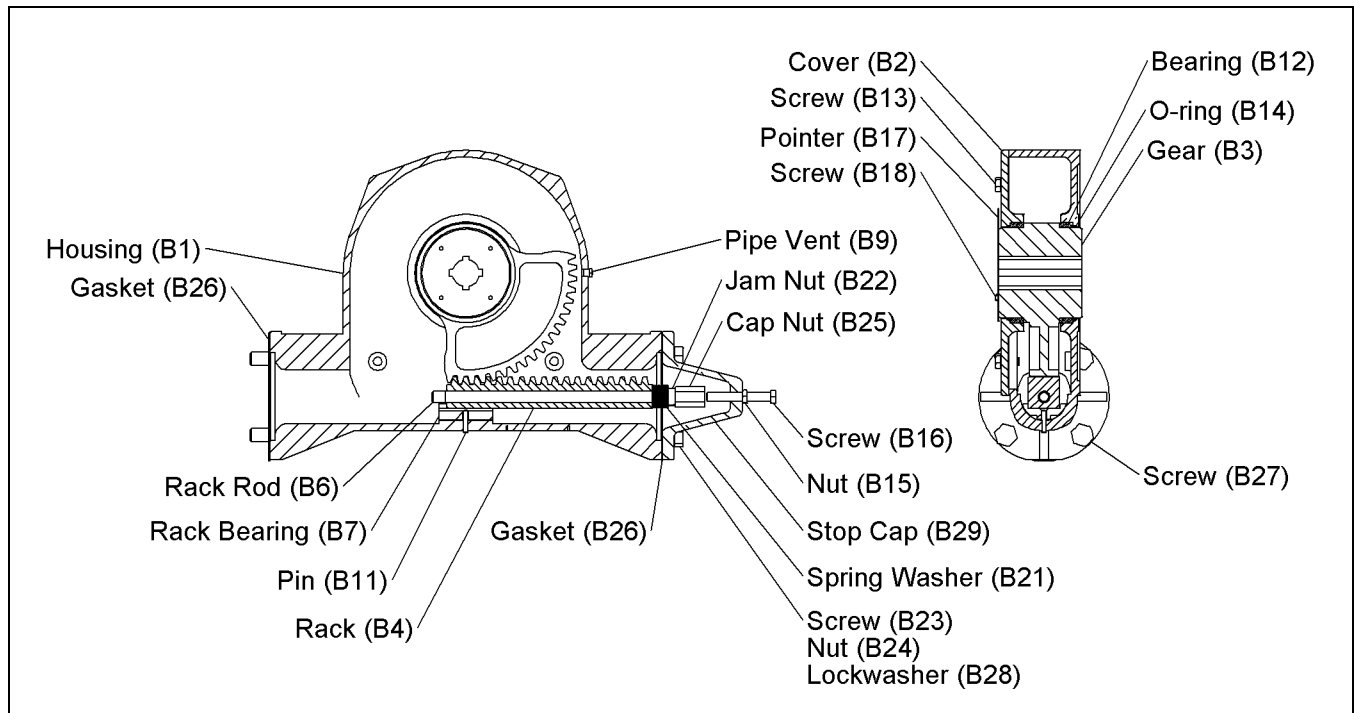

Figure 1 – Cylinder Parts Identification

Parts Identification *(Continued)***Figure 2 – Actuator Parts Identification****Cylinder Inspection Procedure**

See Figures 1 and 2 for parts identification.

**WARNING!**

Never begin disassembling this cylinder until you have inspected the snap ring and have checked for piston rod movement. These inspections will tell you if the compressed spring is properly retained or if the piston rod is stuck. If piston rod is not retained, the spring could be released on disassembly, possibly causing injury.

**WARNING!**

Moving parts from accidental operation of power actuator can cause personal injury or equipment damage. Disconnect and lock out the pneumatic power to actuator before servicing.

1. Disconnect and lock out the pneumatic power to prevent accidental operation of the actuator.
2. Remove the screws (B18) and pointer (B17) from the gear sector (B3).
3. Scribe corresponding lines on the cover (B2) and housing (B1) to be used for alignment during assembly, then remove the screws (B13) fastening the cover to the housing and remove cover so you can see the piston rod (C14) and snap ring (C17).

DeZURIK

Spring Return Cylinder Operator

Cylinder Inspection Procedure (Continued)

4. Pressurize the cylinder. Inspect the snap ring (C17) on the end of the piston rod (C14). See Figure 3.



WARNING!

If the snap ring is missing or damaged, do not disassemble the cylinder. Remove the cylinder assembly from the actuator and return the cylinder to DeZURIK.

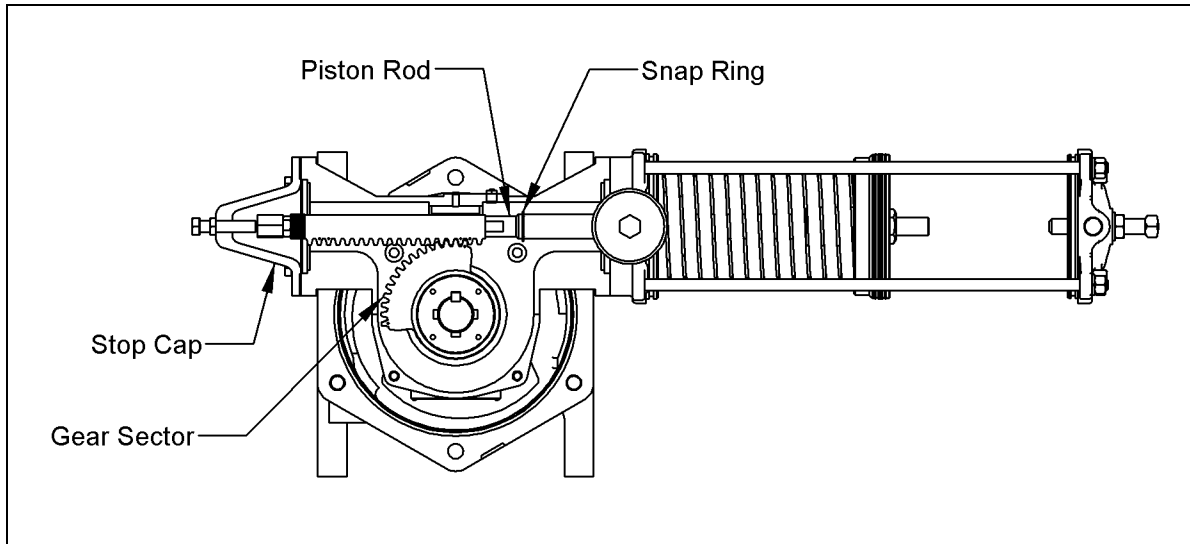

Figure 3 – Actuator Shown with Cylinder Pressurized

5. While watching the piston rod (C14), relieve the cylinder pressure.

Note: The piston rod must move freely, see warning below.



WARNING!

If the piston rod does not move, do not disassemble the cylinder. Remove the cylinder from the actuator and return the cylinder to DeZURIK.

6. Scrape the old gasket material from the housing (B1) and cover (B2).
7. Apply a thin bead of silicone sealant Dow RTV-732 to the cover (B2). Line up the scribe marks on the cover and housing (B1) and attach the cover with screws (B13).
8. Attached the pointer (B17) to the gear sector (B3) with screws (B18).

NOTE: Make sure the pointer is pointing to the appropriate mark on the cover.

Cylinder Disassembly

See Figures 1 and 2 for parts identification.



WARNING!

Never begin disassembling this cylinder until you have inspected the snap ring and have checked for piston rod movement.

See the CYLINDER INSPECTION PROCEDURE on page 5 in this Instruction before disassembling the cylinder.

1. Relieve pipeline pressure and discontinue flow.



WARNING!

Moving parts from accidental operation of power actuator can cause personal injury or equipment damage. Relieve cylinder pressure.

2. Relieve cylinder pressure.
3. Remove the screws (B23), nuts (B24), lockwashers (B28) and stop cap (B29) from the housing (B1).
4. Pressurize the cylinder, then remove the cap nut (B25), jam nut (B22) and spring washers (B21) from the rack rod (B6).

Note: On **Spring-to-Open** cylinders, the spring washers (B21) are located on the cylinder end of the rack rod (B6). They will be removed with the cylinder assembly.

5. Relieve the cylinder pressure and disconnect the air supply from the cylinder.
6. Remove the screws (B27) that fasten the cylinder assembly to the housing (B1).
7. Pull the cylinder assembly, complete with rack rod, from the actuator housing.

Note: On **Spring-to-Open** cylinders, the spring washers (B21) are located on the cylinder end of the rack rod (B6). They will be removed with the cylinder assembly.

8. Clamp the rack rod (B6) in a soft-jawed vise.
9. Loosen the jam nut (C2) and remove the set screw (C1) in the cylinder cap.
10. Remove the nuts (C5) and lockwashers (C6) from the tie rods (C4).

11. Remove the cylinder cap (C7).
12. Remove the tie rods (C4).
13. Rotate the cylinder tube (C13) while pulling it off the piston (C10).
14. Remove the locknut (C9) from the piston rod (C14).
15. Unscrew the piston (C10) from the piston rod (C14).
16. Remove the spring (C15).
17. Pull the cylinder head (C16) off the piston rod (C14).

Cylinder Reassembly

See Figures 1 and 2 for parts identification.

1. Replace the O-rings (C8) in the cylinder head (C16) and cylinder cap (C7) if necessary.
2. Replace the piston seal (C11) and piston O-ring (C12) if worn.
3. Replace the rod seal (C23) in the cylinder head (C16).
4. Clamp the rack rod (B6) with the piston rod (C14) in a soft-jawed vise.

Note: Make sure the snap ring (C17) is secure in groove of the piston rod (C14).

5. Lubricate the rod seal (C23), then slide the cylinder head (C16) onto the piston rod (C14).
6. Set the spring (C15) in place and install the piston (C10). Screw the piston on until the dimension shown in Figure 4 is reached.

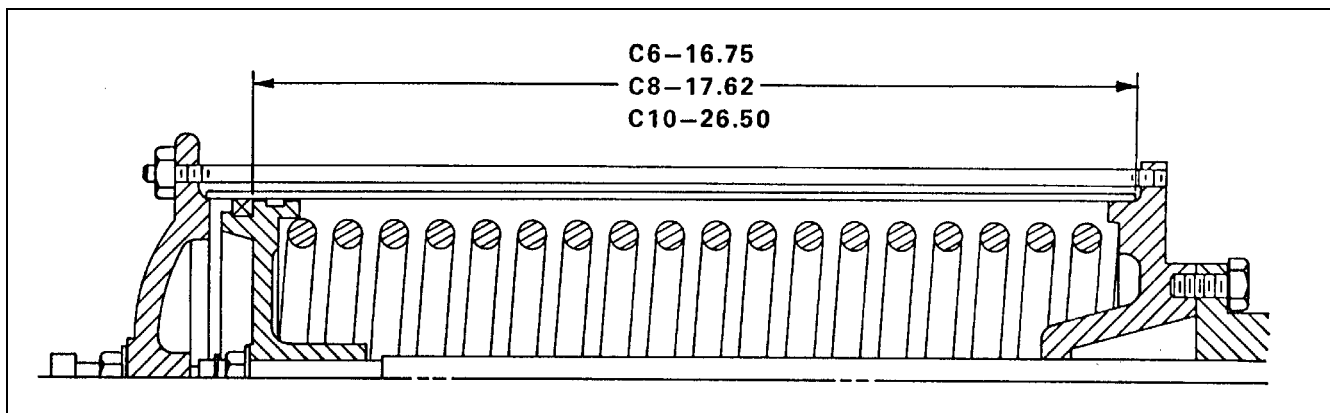

Figure 4 – Piston Length Dimension

7. Install the seal (C20) and locknut (C9) and lock the piston (C10) in place.
8. Coat the piston seal (C11) and the inside of the cylinder tube (C13) with Dow Corning Molykote 44 grease. Slide the cylinder tube over the piston (C10). It will be easier to start the cylinder tube at a 45° angle, then rotate the cylinder tube onto the piston. See Figure 5.

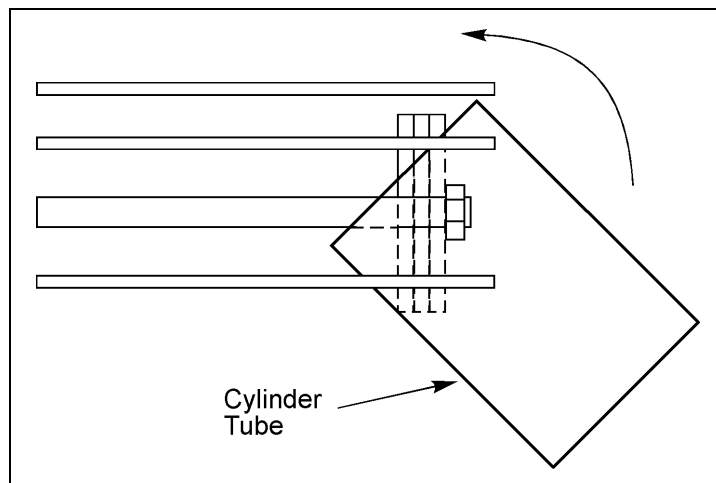

Figure 5 – Cylinder Tube Installation

Cylinder Reassembly *(Continued)*

9. Install the tie rods (C4) and cylinder cap (C7), then secure them in place with the washers (C6) and nuts (C5). Make sure the tag (C21) is under one of the nuts. Tighten the nuts on the tie rods (C4) to the torque specified in Table A.

Table A: Tie Rod Nut Torque

Cylinder Size	Torque ft. lbs.
C6 & C8	16
C10	20

10. Install the thread seal (C3), jam nut (C2) and set screw (C1).
11. Place a new gasket (B26) on the housing (B1) and slide the cylinder assembly into the housing and thru the rack (B4).
12. Secure the cylinder assembly to the housing (B1) with screws (B27).
13. Position the spring washers (B21) as shown in Figure 6. The spring washers go between the piston rod (C14) and rack (B4) for **Spring-to-Open** applications (see Figure 8) and on the end of the rack (B4) for **Spring-to-Close** applications (see Figure 9).

Stack spring washers (B21) as shown in A except on 8" thru 12" valves with G12 actuators, stack as shown in B.

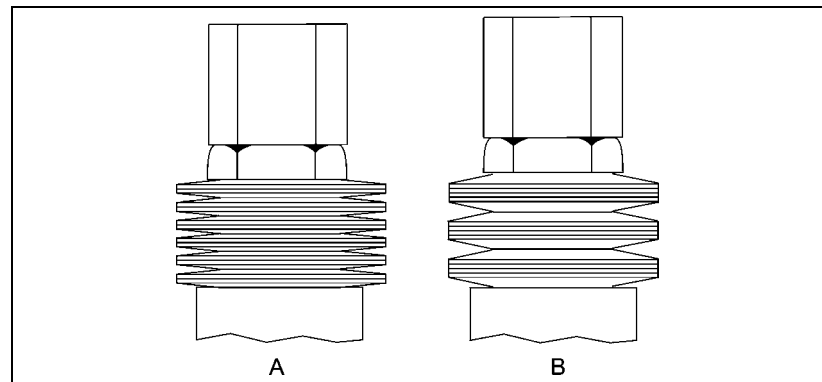
**Figure 6 – Washer Stacking for Different Valve Sizes**

14. Tighten the jam nut (B22) until the spring washers (B21) are completely compressed. Then loosen the jam nut until the spring washers return to their normal shape. Lock the jam nut in place with the cap nut (B25).
15. Reconnect air supply to the cylinder.
16. Adjust the open and closed position stops as described in the STOP ADJUSTMENTS Section of this manual.

DeZURIK

Spring Return Cylinder Operator

Stop Adjustments

See Figures 1 and 2 for parts identification.

Cylinder mounted for Spring-to-Close: Open Position Stop

1. Pressurize the cylinder.
2. While maintaining the pressure, loosen the jam nut (B15) and adjust the set screw (B16) in the stop cap (B29) so the plug is in the open position.
3. Lock the set screw (B16) in place with the jam nut (B15).

Cylinder mounted for Spring-to-Close: Closed Position Stop

1. Relieve the cylinder pressure.
2. Loosen the jam nut (C2) and turn out the set screw (C1) in the end of the cylinder assembly until there is no pressure on it. Then turn it back in until it just contacts the piston rod (C14).
3. Lock the set screw (C1) in place with the jam nut (C2).

Cylinder mounted for Spring-to-Open: Open Position Stop

1. Relieve the cylinder pressure.
2. Loosen the jam nut (C2) and adjust the set screw (C1) in the end of the cylinder assembly so the plug is in the open position.
3. Lock the set screw (C1) in place with the jam nut (C2).

Cylinder mounted for Spring-to-Open: Closed Position Stop

Valves can be mounted with Direct or Reverse pressure. See Figure 7.

Direct Pressure - When the higher pressure is at the end opposite the seat.

Reverse Pressure - When the higher pressure is at the seat end of the valve.

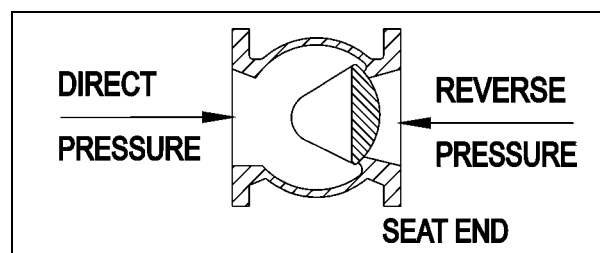

Figure 7 – Pressure Direction

Stop Adjustments *(Continued)*

1. Discontinue flow and relieve pipeline pressure.
2. Relieve the cylinder pressure to open the valve and loosen the jam nut (B15).
3. Back out the set screw (B16) about 1½ turns.
4. Close the valve with the pressure specified in Table B for the appropriate size and pressure direction—See Figure 7.

Direct Pressure (higher pressure is at end opposite the seat); use the cylinder pressure specified in Table B for 25 psi (172 kPa) reverse pressure drop.

Reverse Pressure (higher pressure is at seat end of valve); use the cylinder pressure specified in Table B for the amount of reverse pressure drop in your pipeline.

The pressure in Table B will provide tight shut off or minimum leakage (depending on pressure drop) with maximum plug life. If the reverse pressure drop in the pipeline is unknown, set closing pressure for the maximum pressure drop. Reset the closing pressure as soon as actual pressure drop can be determined because the maximum setting decreases plug life.

5. Maintain pressure for 5 minutes to allow the plug to seat, then lock the setscrew (B16) in place with the jam nut (B15).

DeZURIK

Spring Return Cylinder Operator

Stop Adjustments *(Continued)*

Table B: Cylinder Closing Pressure - Reverse Pressure Drop*

Valve Size	Actuator & Cylinder	Cylinder Closing Pressure (For Direct Pressure Drop Use Same as 25# Reverse)									
		25 psi	172 kPa	50 psi	344 kPa	75 psi	517 kPa	100 psi	689 kPa	125 psi	861 kPa
3" (80mm)	G6-C6	7	48	7	48	8	55	9	62	9	62
4" (100mm)	G6-C6	7	48	7	48	8	55	9	62	9	62
5" (125mm)	G6-C6	10	68	11	75	12	82	13	89	14	96
6" (150mm)	G6-C6	10	68	11	75	12	82	13	89	14	96
8" (200mm)	G6-C6	20	137	22	151	25	172	28	193	—	—
	G6-C8	11	75	13	89	15	103	16	110	—	—
	G12-C6	10	68	11	75	13	89	14	96	15	103
	G12-C8	6	41	7	48	8	55	8	55	9	62
10" (250mm)	G6-C6	30	206	36	248	—	—	—	—	—	—
	G6-C8	17	117	20	137	—	—	—	—	—	—
	G12-C6	15	103	18	124	21	144	24	165	26	179
	G12-C8	9	62	10	68	12	82	14	96	15	103
	G12-C10	6	41	7	48	8	55	9	62	10	68
12" (300mm)	G6-C6	41	282	—	—	—	—	—	—	—	—
	G6-C8	23	158	—	—	—	—	—	—	—	—
	G12-C6	21	144	26	179	30	206	35	241	—	—
	G12-C8	12	82	15	103	17	117	20	137	22	151
	G12-C10	8	55	10	68	11	75	13	89	14	96
14" (350mm)	G12-C8	15	103	19	131	24	165	28	193	—	—
	G12-C10	10	68	13	89	15	103	18	124	—	—
16" (400mm)	G12-C8	18	124	24	165	—	—	—	—	—	—
	G12-C10	12	82	16	110	19	131	—	—	—	—
18" (450mm)	G12-C8	21	144	29	199	—	—	—	—	—	—
	G12-C10	14	96	19	131	—	—	—	—	—	—
20" (500mm)	G12-C8	24	165	34	234	—	—	—	—	—	—
	G12-C10	15	103	22	151	—	—	—	—	—	—

* Reverse Pressure Drop: The pressures specified for reverse pressure drop will provide tight pressure shutoff or minimum leakage with maximum plug life. If a dead-tight shutoff with reverse pressure is required, contact DeZURIK.

Changing the Action

See Figures 1 and 2 for parts identification.

When eccentric valves are mounted in a vertical pipeline, or mounted in a horizontal pipeline with the plug stem horizontal, gravity can cause the plug to swing to a lower position in the valve body when the actuator is removed. To avoid this problem, place the plug in the lowest position before removing the actuator.



WARNING!

When the actuator is removed, be careful of moving parts. The Spring in the cylinder is compressed when air pressure is supplied to the cylinder. Relieving cylinder pressure allows the spring to pull the piston rod and the rack.

Relieve pipeline pressure whenever possible.

If the valve is in a pressurized pipeline, be sure the valve is in the closed position when the gear sector is removed. This prevents water hammer that could result if pipeline pressure slams the valve closed.

In the **Spring-to-Close** cylinder, the spring force must cause clockwise rotation of the plug.

In the **Spring-to-Open** cylinder, applying cylinder air pressure must cause clockwise rotation of the plug.

Changing the cylinder action requires changing the orientation of the rack and gear. The location of the spring washers on the rack rod is also changed. To change from Spring-to-Close to Spring-to-Open, see Section A below. To change from Spring-to-Open to Spring-to-Close, see Section B.

DeZURIK

Spring Return Cylinder Operator

Changing the Action *(Continued)*

Section A: From Spring-to-Close to Spring-to-Open

This procedure can be performed with the actuator installed on the valve or removed. See Figure 8 for Spring-to-Open assembly.

1. Discontinue flow and relieve pipeline pressure.
2. Relieve pressure in the cylinder.
3. Remove the screws (B23), nuts (B24), lockwashers (B28) and stop cap (B29) from the housing (B1).
4. Pressurize the cylinder. Maintain the cylinder pressure and remove the cap nut (B25), jam nut (B22) and spring washers (B21) from the end of the rack rod (B6).



WARNING!

Accidental operation of power actuator can cause personal injury or equipment damage. Disconnect and lock out pneumatic power to actuator before servicing.

5. Relieve pressure in the cylinder. Disconnect and lock out the pneumatic power to prevent accidental operation of the actuator.
6. Remove the screws (B27) fastening the cylinder assembly to the housing (B1), and carefully remove the cylinder assembly by sliding it away from the actuator until the rack rod (B6) clears the housing.
7. Remove the screws (B18) and pointer (B17) from the gear sector (B3).
8. Scribe corresponding lines on the cover (B2) and housing (B1) to be used for alignment during assembly, then remove the screws (B13) fastening the cover to the housing and remove cover.
9. Lift the gear sector (B3) off the valve shaft, slide the rack (B4) away from the cylinder end of the housing (B1) one tooth. Then slide the gear sector back onto the valve shaft. See Figure 8 for tooth alignment detail.
10. Scrape the old gasket material (B26) from the actuator housing and cylinder head. Then place a new gasket (B26) on the cylinder head.
11. Slide the spring washers (B21) onto the rack rod. See Figure 6 for spring washer arrangement.

NOTE: If the rack rod (B6) is not attached to the cylinder assembly, clean the threads of both the rack rod and the cylinder shaft, then apply Loctite to the cylinder shaft threads and screw the rack rod onto the cylinder shaft.

NOTE: The spring washers (B21) will be located between the piston rod and rack (B4) once the cylinder assembly is installed.

12. Install the cylinder/rack rod assembly by sliding the rack rod through the opposite end of the housing (B1) and the rack (B4) and fasten the cylinder assembly to the housing with screws (B27). See Figure 8 for Spring-to-Open assembly.
13. Reconnect the air supply to the cylinder and pressurize the cylinder
14. Maintain the cylinder pressure and screw the jam nut (B22) onto the rack rod (B6) until the spring washers (B21) are completely compressed, then loosen the jam nut just until the spring washers return to normal shape.

Changing the Action *(Continued)*

15. Maintain the cylinder pressure and screw the cap nut (B25) onto the rack rod (B6) and tighten the two nuts against each other. Relieve the cylinder pressure.
16. Scrape old gasket material (B26) from the housing (B1) and stop cap (B29).
17. Attach a new gasket (B26) and stop cap (B29) to the housing (B1) with screws (B23), nuts (B24) and lockwashers (B28).
18. Scrape old gasket material from the housing (B1) and cover (B2).
19. Apply a thin bead of silicone sealant Dow RTV-732 to the cover (B2). Line up the scribe marks on the cover and housing (B1) and attach the cover with screws (B13).
20. Attached the pointer (B17) to the gear sector (B3) with screws (B18).

NOTE: Make sure the pointer is pointing to the Open mark on the cover (B2).

21. Adjust the open and closed position stops described in the “*Stop Adjustments*” section.

Section B: From Spring-to-Open to Spring-to-Close

This procedure can be performed with the actuator installed on the valve or removed. See Figure 9 for Spring-to-Close assembly.

1. Discontinue flow and relieve pipeline pressure.
2. Relieve pressure in the cylinder.
3. Remove the screws (B23), nuts (B24), lockwashers (B28) and stop cap (B29) from the housing (B1).
4. Pressurize the cylinder. Maintain the cylinder pressure and remove the cap nut (B25), jam nut (B22) and spring washers (B21) from the end of the rack rod (B6).

**WARNING!**

Accidental operation of power actuator can cause personal injury or equipment damage. Disconnect and lock out pneumatic power to actuator before servicing.

5. Relieve pressure in the cylinder. Disconnect and lock out the pneumatic power to prevent accidental operation of the actuator.
6. Remove the screws (B27) fastening the cylinder assembly to the housing (B1) and carefully remove the cylinder assembly by sliding it away from the actuator until the rack rod (B6) clears the housing.
7. Remove the spring washers (B21) from the rack rod (B6).
8. Remove the screws (B18) and pointer (B17) from the gear sector (B3).
9. Scribe corresponding lines on the cover (B2) and housing (B1) to be used for alignment during assembly, then remove the screws (B13) fastening the cover to the housing and remove cover.
10. Lift the gear sector (B3) off the valve shaft, slide the rack (B4) away from the cylinder end of the housing (B1) one tooth. Then slide the gear sector back onto the valve shaft. See Figure 9 for tooth alignment detail.
11. Scrape the old gasket material (B26) from the actuator housing and cylinder head. Then place a new gasket (B26) on the cylinder head.

DeZURIK

Spring Return Cylinder Operator

Changing the Action *(Continued)*

12. Install the cylinder/rack rod assembly by sliding the rack rod through the opposite end of the housing (B1) and the rack (B4) and fasten the cylinder assembly to the housing with screws (B27). See Figure 9 for Spring-to-Close assembly.

NOTE: If the rack rod (B6) is not attached to the cylinder assembly, clean the threads of both the rack rod and the cylinder shaft, then apply Loctite to the cylinder shaft threads and screw the rack rod onto the cylinder shaft.

13. Reconnect the air supply to the cylinder and pressurize the cylinder
14. Maintain the cylinder pressure and slide the spring washers (B21) onto the rack rod (B6). See Figure 6 for spring washer arrangement.

NOTE: The spring washers (B21) will be located at the end of the rack (B4) opposite the cylinder assembly.

15. Maintain the cylinder pressure and screw the jam nut (B22) onto the rack rod (B6) until the spring washers (B21) are completely compressed, then loosen the jam nut just until the spring washers return to normal shape.
16. Maintain the cylinder pressure and screw the cap nut (B25) onto the rack rod (B6) and tighten the two nuts against each other. Relieve the cylinder pressure.
17. Scrape old gasket material (B26) from the housing (B1) and stop cap (B29).
18. Attach a new gasket (B26) and stop cap (B29) to the housing (B1) with screws (B23), nuts (B24) and lockwashers (B28).
19. Scrape old gasket material from the housing (B1) and cover (B2).
20. Apply a thin bead of silicone sealant Dow RTV-732 to the cover (B2). Line up the scribe marks on the cover and housing (B1) and attach the cover with screws (B13).
21. Attached the pointer (B17) to the gear sector (B3) with screws (B18).

NOTE: Make sure the pointer is pointing to the Closed mark on the cover (B2).

22. Adjust the open and closed position stops described in the “*Stop Adjustments*” section

Changing the Action (Continued)

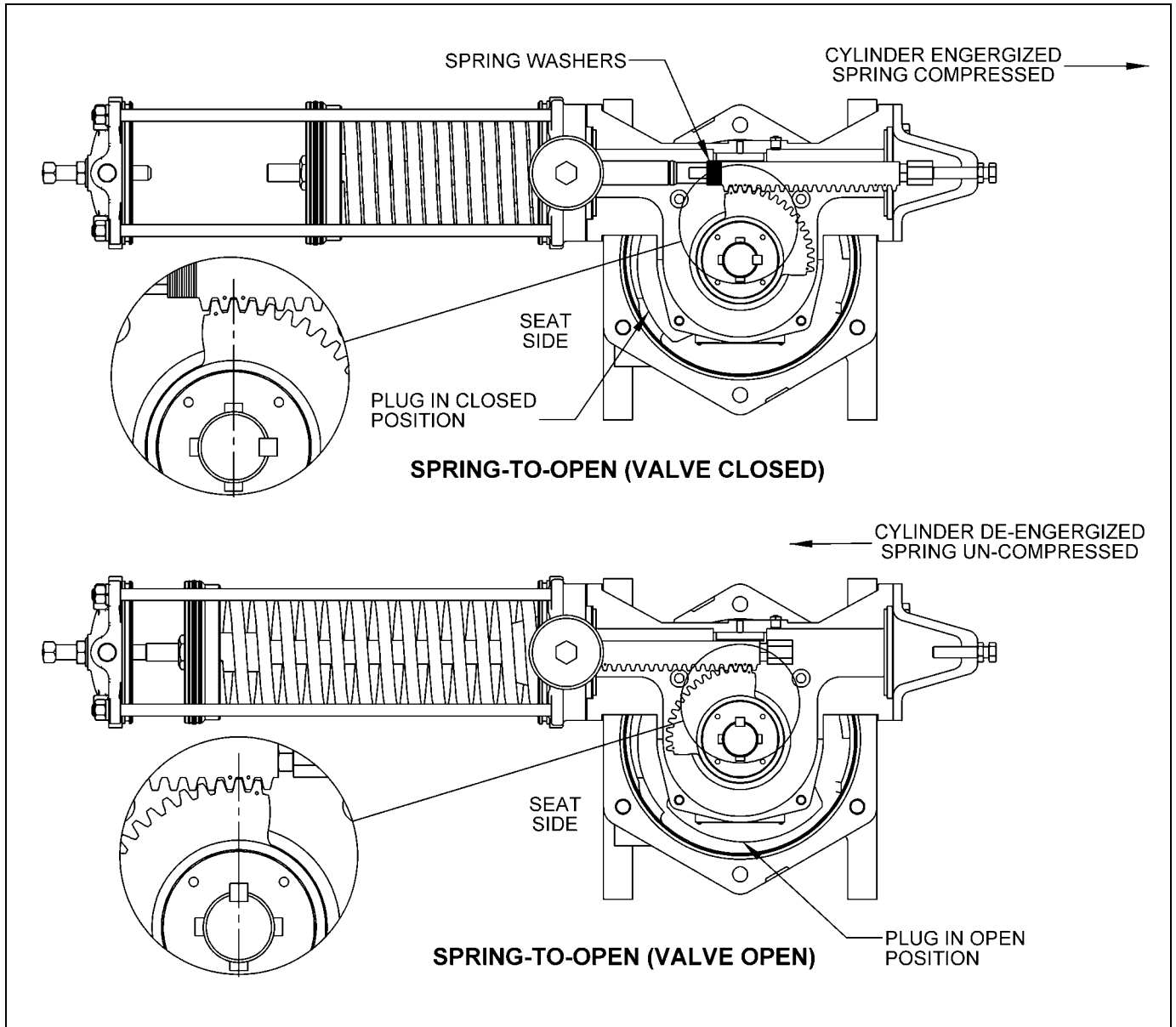

Figure 8 – Actuator Spring-To-Open (6A actuator shown)

DeZURIK

Spring Return Cylinder Operator

Changing the Action (Continued)

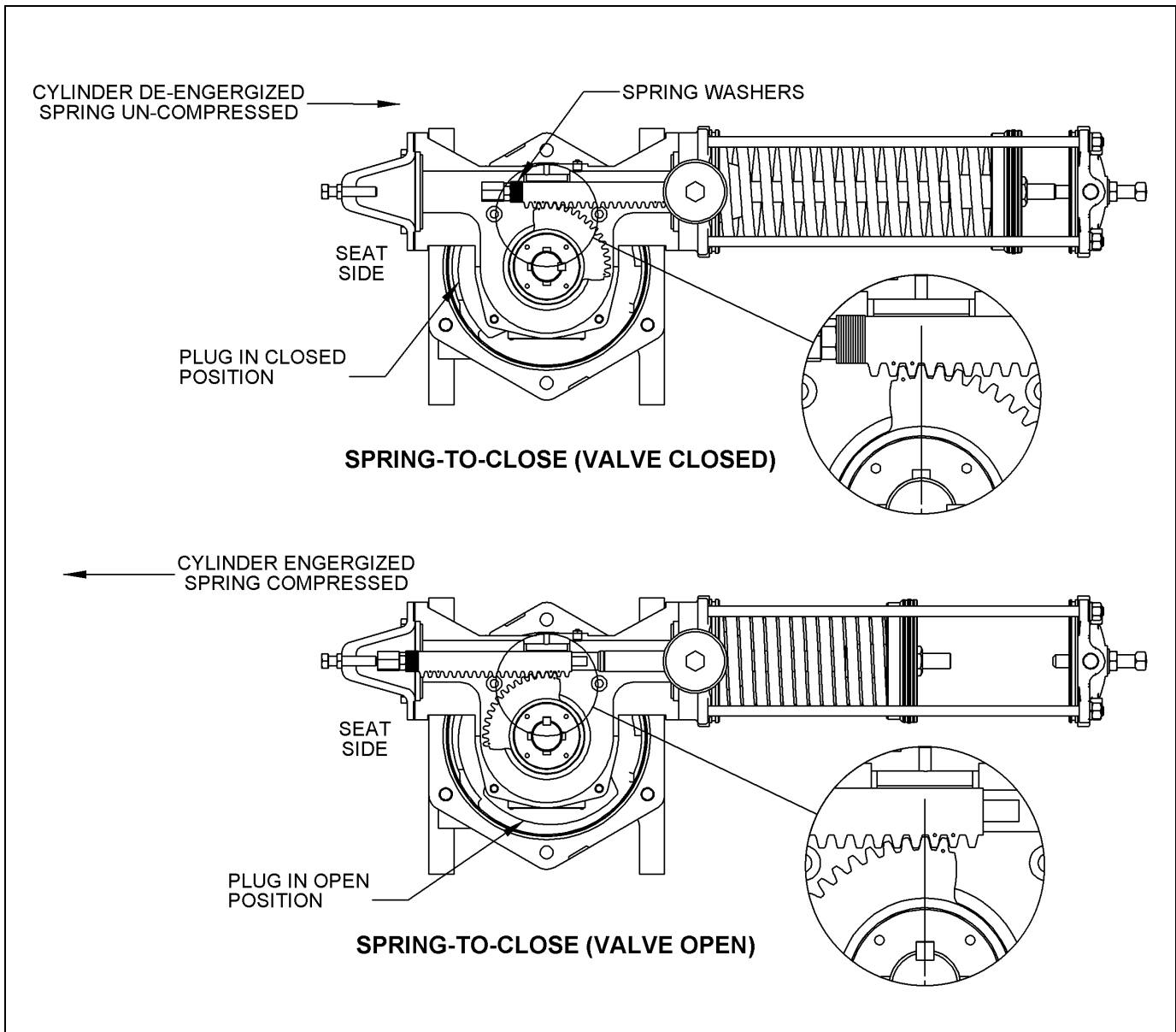

Figure 9 – Spring-To-Close Actuator (6A actuator shown)

Removing Cylinder

This procedure can be performed with the actuator installed on the valve or removed. See Figures 1 and 2 for parts identification.

1. Discontinue flow and relieve pipeline pressure.



WARNING!

Accidental operation of power actuator can cause personal injury or equipment damage. Disconnect and lock out pneumatic power to actuator before servicing.

2. Disconnect and lock out the pneumatic power to prevent accidental operation of the actuator.
3. Disconnect the tubing from cylinder port.
4. Remove the screws (B23), nuts (B24), lockwashers (B28) and stop cap (B29) from the housing (B1).
5. Remove the cap nut (B25), jam nut (B22) and spring washers (B21) from the end of the rack rod (B6).

Note: On **Spring-to-Open** cylinders, the spring washers (B21) are located on the cylinder end of the rack rod (B6). They will be removed with the cylinder assembly.

6. Remove the screws (B27) fastening the cylinder assembly to the housing (B1), and carefully remove the cylinder assembly by sliding it away from the actuator until the rack rod clears the housing.