



**MODELS P41, P41D AND
P42 PMV POSITIONERS**

DeZURIK

Models P41, P41D and P42 PMV Positioners

Instructions

These instructions provide information about Models P41, P41D and P42 PMV Positioners. They are for use by personnel who are responsible for installation, operation and maintenance of Models P41, P41D and P42 PMV Positioners.

Safety Messages

All safety messages in the instructions are flagged with an exclamation symbol and the word Caution, Warning or Danger. These messages indicate procedures that must be followed exactly to avoid equipment damage, personal injury or death. Safety label(s) on the product indicate hazards that can cause equipment damage, personal injury or death. If a safety label becomes difficult to see or read, or if a label has been removed, please contact DeZURIK for replacement label(s).



WARNING!

Personnel involved in the installation or maintenance of valves should be constantly alert to potential emission of pipeline material and take appropriate safety precautions. Always wear suitable protection when dealing with hazardous pipeline materials. Handle valves that have been removed from service with the assumption of pipeline material within the valve.

Inspection

Your Model P41, P41D or P42 PMV Positioner has been packaged to provide protection during shipment; however, it can be damaged in transport. Carefully inspect the unit for damage upon arrival and file a claim with the carrier if damage is apparent.

Parts

Order parts from your local DeZURIK sales representative, or directly from DeZURIK. When ordering parts, please include the 7-digit part number and 4-digit revision number (example: **9999999R000**) located on the data plate attached to the valve assembly. Also include the part name, the assembly drawing number, the balloon number and the quantity stated on the assembly drawing.

DeZURIK Service

DeZURIK service personnel are available to install, maintain and repair all DeZURIK products. DeZURIK also offers customized training programs and consultation services.

For more information, contact your local DeZURIK sales representative or visit our website at www.dezurik.com.

Table of Contents

Description - - - - -	4
Cam Selection - - - - -	4
Installation - - - - -	4
<i>Air and Electrical Connections</i> - - - - -	4
Maintenance	
<i>Cleaning Positioner Body</i> - - - - -	5
<i>Cleaning the Restriction Plug</i> - - - - -	6
Adjustments - - - - -	6
<i>Linkage Rod Adjustment</i> - - - - -	6
<i>Zero Adjustment</i> - - - - -	7
<i>Range Adjustment</i> - - - - -	7
<i>Gain Adjustment</i> - - - - -	8
Reversing Valve Action - - - - -	9
Trouble Shooting - - - - -	10

DeZURIK

Models P41, P41D and P42 PMV Positioners

Description

The Model P41, P41D and P42 PMV Electro-Pneumatic positioner is a precision instrument which, when used in conjunction with a cylinder actuator, can provide the exacting control necessary to satisfy the most demanding process requirements. The positioner will accept either a 0–20mA or 4–20mA input signal.

Cam Selection

Each cam is designed to provide split range instrument signals. Standard cam characterization is linear; however, other characterizations are available.

Installation



WARNING!

Positioners installed in hazardous areas can be ignition sources. Ensure positioners used in hazardous areas have proper fire/explosion ratings.

Air and Electrical Connections

1. Connect instrument quality supply air to the positioner "S" port.

Note: Supply air should be clean, dry and oil-free, with pressure not exceeding the maximum pressure rating of the cylinder.

2. Remove the top cover and the side frame from the positioner to allow access to the terminal block.
3. Connect input signal wires to the terminal block inside the positioner.

Note: The positioner case has a 1/2" NPT hole for wiring connector.

4. Actuator piping is connected at the factory to positioner ports C1 and C2. When used on spring-return actuators, one of the ports is plugged.

Maintenance

Cleaning Positioner Body

To ensure proper positioner operation, it is necessary to periodically clean the positioner valve body and the restriction plug according to the following steps.

1. Close the valve..

**WARNING!**

Failure to close the valve may result in the valve slamming shut while the positioner is being cleaned..

2. Disconnect supply air and instrument signal to the positioner.
3. Remove cylinder tubing from the positioner.
4. Remove the four positioner cover screws and the cover.
5. Remove the side frame from the positioner.
6. Make a note of the position of the indicator, then remove the indicator screw and the indicator.
7. Remove the three screws that hold the valve body to the positioner housing, and carefully lift out the valve body.
8. Ensure the spool does not bind against the tip of the balance arm. See Figure 1 for parts location.

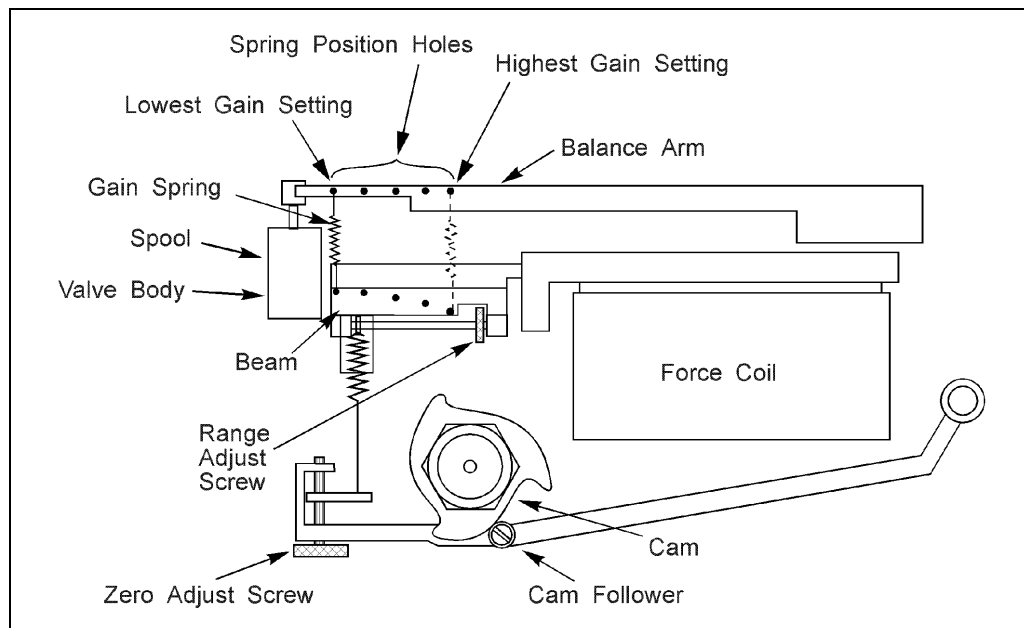

Figure 1 – Component Identification

9. Pull the spool out of the body and wash the components.
10. Dry the parts with compressed air, and ensure the ports are clear.

DeZURIK

Models P41, P41D and P42 PMV Positioners

Maintenance *(continued)*

11. Replace any worn components, then install the spool into the valve body,.
12. Fasten the valve body to the positioner housing and tighten the screws evenly.
13. Place the indicator in the position noted in Step 6, and secure with the screw.
14. Install the side frame and the positioner cover.
15. Connect the tubing from the cylinder to the positioner.
16. Connect supply air and instrument signal to the positioner.

Cleaning the Restriction Plug

1. Remove the restriction plug. (See Figure 2.)
2. Clean the restriction hole (drilled crosswise through the restriction plug) with a fine (0.007inch diameter) wire.

Note: Do not enlarge the restriction hole.

3. Inspect the O-rings, then install the restriction plug.
4. Install an in-line air filter in the positioner supply port.

Note: Contact the DeZURIK Parts Department to order the filter.

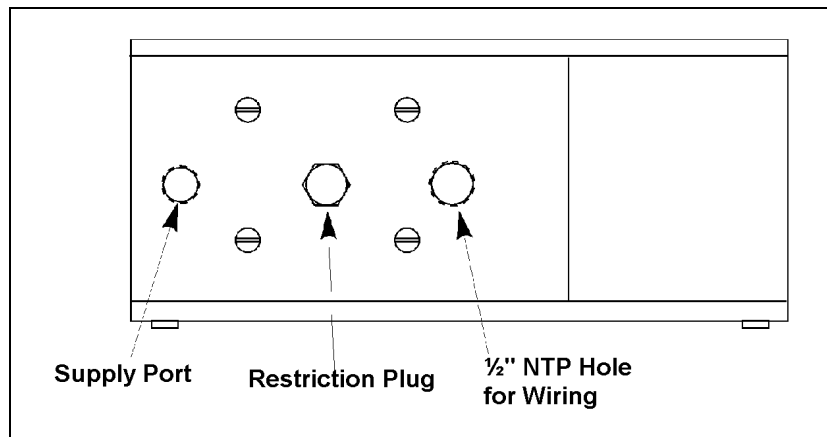

Figure 2 – Restriction Plug Location

Adjustments

These instructions are written for a unit that is piped to Open the valve on an increasing signal. If your unit is piped to Close the valve on an increasing signal, the valve action will be the opposite of what is described here.

Linkage Rod Adjustment

If valve position feedback is transmitted through a linkage rod, adjust the length of the rod as follows:

1. Remove the top cover and side frame from the positioner body before adjusting.
2. Set the positioner input signal at the minimum value of its range; for example, 4mA for a 4-20mA range.

Adjustments *(continued)*

3. Adjust the length of the rod until the valve is in the position corresponding to the minimum input signal.

Zero Adjustment

1. Set the positioner input signal at the minimum value of its range, for example, 4mA for a 4-20mA range.
2. Turn the zero adjust screw clockwise until the valve closes. (See Figure 1 for location of adjusting screws.)
3. Increase the instrument signal slightly above the minimum range value.

Note: If the valve does not begin to open, turn the zero adjust screw counterclockwise until the valve just starts to move.

4. Since the zero and range adjustments are interrelated, check the range setting and readjust it, if necessary.

Range Adjustment

1. Set the positioner input signal at 20mA.
2. Turn the range adjust screw until the valve is in the OPEN position.
3. Decrease the input signal slightly.
4. If the valve does not begin to close, turn the range adjust screw until the valve just starts to move.
5. Since the zero and range adjustments are interrelated, check the zero setting and readjust it, if necessary.

DeZURIK

Models P41, P41D and P42 PMV Positioners

Adjustments *(continued)*

Gain Adjustment

The gain adjustment is preset at the factory to match your actuator under average conditions. Table A lists the factory presets.

If it is necessary to adjust the gain, follow the appropriate procedure:

TO REDUCE GAIN - Move the gain spring away from the force coil. Ensure the spring is securely hooked in the beam holes and balance arm notches.

TO INCREASE GAIN - Move the gain spring toward the force coil. Ensure the spring is securely hooked in the beam holes and balance arm notches.

Note: After adjusting the gain, you must readjust the zero and range settings.

Table A: Gain Spring Position Settings

Actuator	Spring Position
G2C6	Lowest Setting
R1C4	
R1C6	
R2C6	
DR40	
G4C8	Second from Lowest Setting
R2C8	
G6C4	Middle Setting
G6C6	
G6C8	
G12C6	
G12C8	
G12C10	
R3C8	
R3C10	
DR55/85	Highest Setting
DR145/250	

Reversing Valve Action

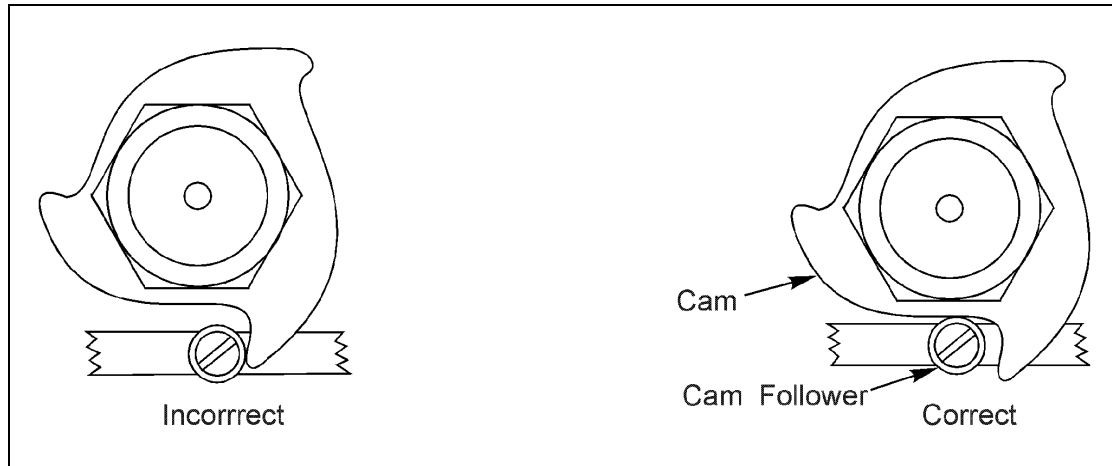

Figure 3 – Cam Position

To change from having the valve Open, to having it Close, on an increasing signal, follow the steps below:

1. Close the valve. (Failure to close the valve may result in the valve slamming shut.)
2. Relieve supply air pressure.
3. Reverse the cylinder tubing connections at positioner ports C1 and C2.
4. Remove the four screws that fasten the positioner cover to the positioner, and remove the cover.
5. Note the position of the indicator, then remove the indicator screw and indicator.
6. Note the cam range being used, then remove the nut and cam.
7. Invert the cam and install it on the input shaft.

Note: Thread the nut loosely.
8. Connect the air supply.
9. Set the positioner input signal at the minimum value of its range, for example, 4mA for a 4–20mA range.
10. Position the cam as shown in the right side of Figure 3.

Note: Ensure the ball bearing does not ride up on the inactive portion of the cam.
11. Tighten the cam nut.

Note: The cam will turn slightly with the nut as it is tightened. Turn the cam slightly counterclockwise before tightening the nut, to allow for this.
12. Install the position indicator and the positioner cover.

DeZURIK

Models P41, P41D and P42 PMV Positioners

Troubleshooting

Condition	Possible Cause	Corrective Action
Signal change has no effect on actuator position	No supply air pressure.	Check for correct air supply.
	Signal wires connected wrong.	Check markings on terminal block.
	Broken wire between positioner terminal block and printed circuit board.	Check continuity of wiring, and check for tight connections.
	Piping between positioner and actuator is wrong.	See Assembly Drawing for correct piping.
	Wrong portion of cam being used.	See Figure 3.
A slight change in input signal fully actuates valve	Piping between positioner and actuator is wrong.	See Assembly Drawing for correct piping.
Inaccurate positioning	Valve body dirty.	See "Maintenance" section.
	Restrictor or nozzle dirty.	See "Maintenance" section
	Magnet gap has iron dust.	Clean gap.
	Supply pressure too low.	Check for correct air supply.
	Torque needed to turn valve has increased.	Look for valve obstructions or fouling.
Overshoot or hunting during positioning	Gain setting wrong.	See "Adjustments" section.
	Capacity of supply piping too low, or air filter is plugged.	Check for correct air supply and clean the filter.