



**ANSI/AWWA C540  
HYDRAULIC CYLINDER  
FOR G-SERIES ACTUATORS**

# DeZURIK

## ANSI/AWWA C540-87 Hydraulic Cylinder for G-Series Actuators

---

**Instructions** These instructions provide information about ANSI/AWWA C540 Hydraulic Cylinders. They are for use by personnel who are responsible for installation, operation and maintenance of ANSI/AWWA C540 Hydraulic Cylinders.

**Safety Messages** All safety messages in the instructions are flagged with an exclamation symbol and the word Caution, Warning or Danger. These messages indicate procedures that must be followed exactly to avoid equipment damage, personal injury or death.

Safety label(s) on the product indicate hazards that can cause equipment damage, personal injury or death. If a safety label becomes difficult to see or read, or if a label has been removed, please contact DeZURIK for replacement label(s).



### **WARNING!**

**Personnel involved in the installation or maintenance of valves should be constantly alert to potential emission of pipeline material and take appropriate safety precautions. Always wear suitable protection when dealing with hazardous pipeline materials. Handle valves which have been removed from service with the assumption of pipeline material within the valve.**

---

**Inspection** Your ANSI/AWWA C540 Hydraulic Cylinder has been packaged to provide protection during shipment, however, it can be damaged in transport. Carefully inspect the unit for damage upon arrival and file a claim with the carrier if damage is apparent.

**Parts** Recommended spare parts are listed on the assembly drawing. These parts should be stocked to minimize downtime.

Order parts from your local DeZURIK sales representative, or directly from DeZURIK. When ordering parts, please include the 7-digit part number and 4-digit revision number (example: **9999999R000**) located on the data plate attached to the valve assembly. Also include the part name, the assembly drawing number, the balloon number and the quantity stated on the assembly drawing.

**DeZURIK Service** DeZURIK service personnel are available to install, maintain and repair all DeZURIK products. DeZURIK also offers customized training programs and consultation services.

For more information, contact your local DeZURIK sales representative or visit our website at [www.dezurik.com](http://www.dezurik.com).

<b>Table of Contents</b>	Description .....	2
	Supply .....	2
	Tools Required .....	2
	Lubrication .....	2
	Adjustment .....	2
	Disassembly .....	2
	Reassembly .....	3

# DeZURIK

## ANSI/AWWA C540-87 Hydraulic Cylinder for G-Series Actuators

---

**Description** The ANSI/AWWA C540 Hydraulic Cylinder for use with G-Series Actuators is intended for water hydraulic service. This cylinder can be used with Pumpcheck accessories.

**Supply** The maximum cylinder supply pressure is 150 psi. The supply medium is clean water.

**Tools Required** The cylinder is assembled with SAE fasteners. Tools required for adjustment and disassembly include a set of combination wrenches, a flat-tipped screwdriver and a small hammer.



### **WARNING!**

**This cylinder is a pressure vessel. Supply pressure must be disconnected from the cylinder and the cylinder completely relieved of pressure before disassembling the cylinder. Failure to release pressure may result in personal injury and/or damage to other equipment.**

---

**Lubrication** If the cylinder is disassembled, lubricate the cylinder wall, piston seal, U-cup and U-cup groove using one of these lubricants.

- Dow Corning Molykote No. 44 (**recommended**)
- Shell Retinax AM (alternate)
- Shell Lithall MDS (alternate)

**Adjustment** The set screw in the end of the cylinder is used to limit the cylinder stroke.

1. Turn the set screw in the end of the cylinder counterclockwise about five turns.
2. Close the valve. See Valve Instructions to determine closed position.
3. Turn the set screw clockwise until you feel resistance as it contacts the piston rod.
4. Lock the set screw in place with the nut. Be sure the thread seal is positioned properly.

**Disassembly** Follow the steps below to disassemble the cylinder.

1. Shut off the air supply to the cylinder.
2. If the actuator is powered, disconnect and lock out the pneumatic, hydraulic, or electrical power to prevent accidental operation of the actuator.



### **WARNING!**

**Moving parts from accidental operation of power actuator can cause personal injury or equipment damage. Disconnect and lock out power to actuator before servicing.**

---

3. Relieve pressure in the cylinder.
4. Disconnect the cylinder tubing.
5. Remove nuts and washers from the tie rods, and remove cylinder cap.

**Disassembly**  
*(Continued)*

6. Rotate the cylinder tube while pulling it from the piston.
7. Remove the nut on the piston rod.
8. Remove the piston.
9. Remove extension cap from other end of gear box housing.
10. Remove nuts and spring washers from the rack rod.
11. Pull the piston rod, complete with rack rod, from the cylinder head.
12. Take out the four screws and separate the cylinder head from the actuator housing.
13. Remove the seal in the cylinder head.

**Reassembly**

1. Install the piston rod seal as shown in Figure 1.

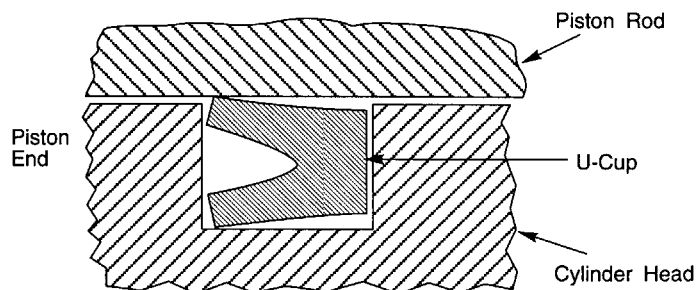

**Figure 1—Piston Rod Seal Placement**

- a. Inspect the scraper in the isolation plate and replace if damaged
  - b. Be sure vent near isolation plate is clear.
  - c. Clean groove in cylinder head and lubricate all parts.
  - d. Insert U-cup in the groove. Make sure the groove in the U-cup faces the piston end of the cylinder head.
2. Attach the isolation plate, then the cylinder head to the actuator. See Figure 2.
  3. Carefully install the rack rod and piston rod.

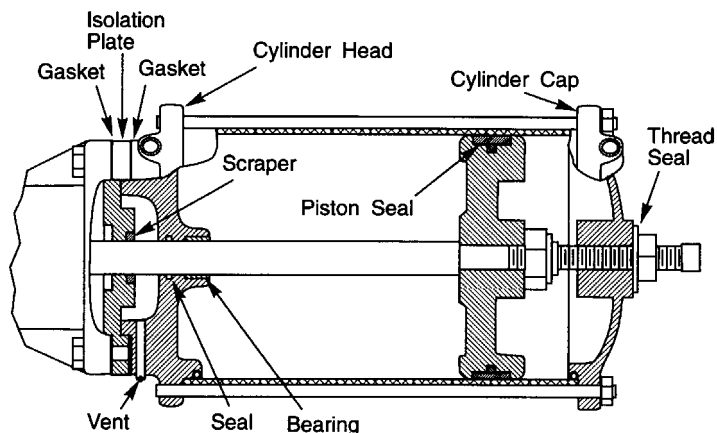

**Figure 2—Cylinder Parts Location**

# DeZURIK

## ANSI/AWWA C540-87 Hydraulic Cylinder for G-Series Actuators

---

### Reassembly (Continued)

4. **Eccentric valves:** Install the spacer, spring washers and nuts on the rack rod. See Table B for spring washer arrangement.  
  
**All other valves:** Install the jam nuts on the rack rod.
5. **Eccentric valves:** Tighten the nut until the spring washers are completely compressed, and then back off until they return to their normal uncompressed shape.  
  
**All other valves:** Tighten the first nut.
6. Tighten the second nut.
7. Install the extension cap.
8. Put the piston on the piston rod and install the nut.
9. Remove the piston seal and its O-ring. Clean the O-ring, seal and groove. Lubricate the O-ring and seal and install them. Use new O-ring and seal if necessary.
10. Lubricate the cylinder tube.
11. Carefully slide the cylinder over the piston. The seal and the cylinder must be well lubricated.
12. On 6-inch and larger cylinders, remove one or two of the tie rods.
13. Start the tube at a 45-degree angle and rotate the tube onto the piston. See Figure 3.

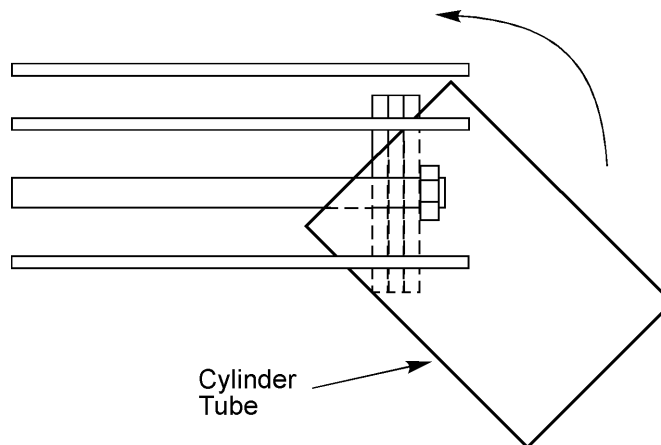

**Figure 3—Installing Cylinder Tube**

14. Clean the O-ring groove in the cylinder cap.
15. Lubricate and install the O-ring in the cylinder cap. Use a new O-ring if necessary.
16. Assemble the cylinder cap, lock washers and nuts. Tighten tie rod nuts to the torque specified in Table A.
17. If the actuator is a powered actuator, reconnect power to the actuator.

# DeZURIK

## ANSI/AWWA C540-87 Hydraulic Cylinder for G-Series Actuators

**Table A: Cylinder Tie Rod Torques**

Cylinder Size	Torque		
	(ft lbs)	(cm/kg)	(Nm)
4"	12	175	16
6" & 8"	16	225	22
10" & 12"	20	275	27
14"	38	526	52

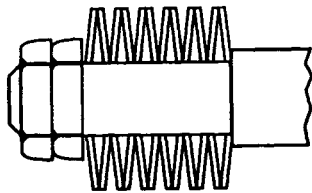

**Arrangement A**

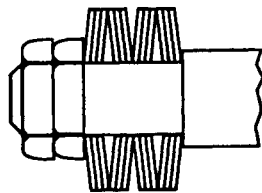

**Arrangement B**

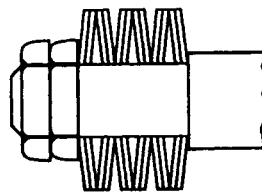

**Arrangement C**

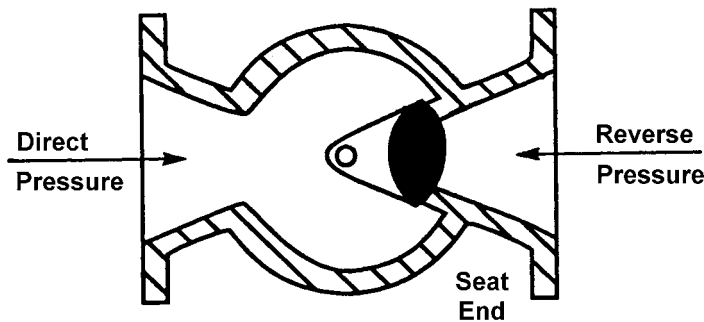

**Direct Pressure:** When the higher-pressure is opposite the seat.

**Reverse Pressure:** When the higher-pressure is at the seat end.

**Table B: Rack Rod Spring Washer**

Valve Size	Actuator Size	Direct Pressure	Reverse Pressure
4	All	A	A
5	All	B	B
6	All	B	B
8	G6	B	B
8	G12	A	A
10	G6	B	B
10	G12	A	B
12	G6	B	B
12	G12	B	B
12	G16	A	A
14	G12	B	B
14	G16	A	A
16	All	B	B
18	All	B	B
20	All	B	B
24	G16 - C8	B	C
24	G16 - C10	B	B
24	G16 - C12	B	C
30	G16 - C8	C	C
30	G16 - C10	B	B
30	G16 - C12	B	C