

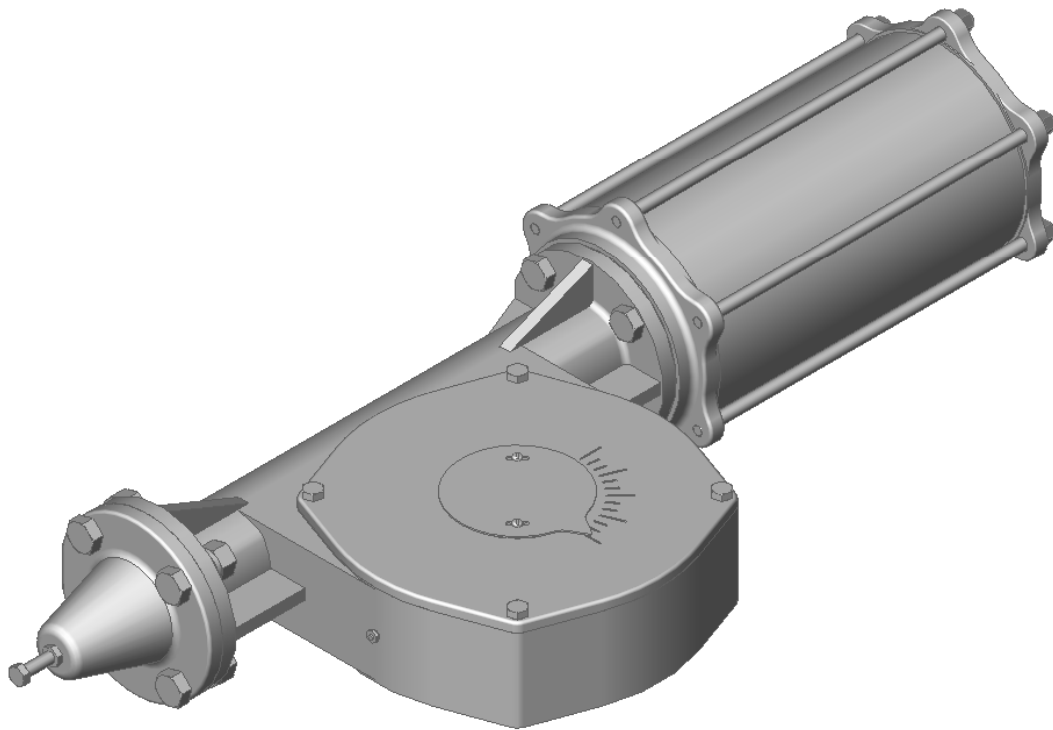

G-SERIES CYLINDER
ACTUATOR
USED ON BAW BUTTERFLY VALVES



Instruction D10480
March 2010

DeZURIK

G-Series Cylinder Actuator Used on BAW Butterfly Valves

Instructions

These instructions provide information about G-Series Cylinder Actuators. They are for use by personnel who are responsible for installation, operation and maintenance of G-Series Cylinder Actuators.

Safety Messages

All safety messages in the instructions are flagged with an exclamation symbol and the word Caution, Warning or Danger. These messages indicate procedures that must be followed exactly to avoid equipment damage, personal injury or death. Safety label(s) on the product indicate hazards that can cause equipment damage, personal injury or death. If a safety label becomes difficult to see or read, or if a label has been removed, please contact DeZURIK for replacement label(s).



WARNING!

Personnel involved in the installation or maintenance of valves should be constantly alert to potential emission of pipeline material and take appropriate safety precautions. Always wear suitable protection when dealing with hazardous pipeline materials. Handle valves, which have been removed from service with the assumption of pipeline material within the valve.

Inspection

Your G-Series Cylinder Actuator has been packaged to provide protection during shipment; however, it can be damaged in transport. Carefully inspect the unit for damage upon arrival and file a claim with the carrier if damage is apparent.

Parts

Recommended spare parts are listed on the assembly drawing. These parts should be stocked to minimize downtime.

Order parts from your local DeZURIK sales representative, or directly from DeZURIK. When ordering parts, please include the 7-digit part number and 4-digit revision number (example: **9999999R000**) located on the data plate attached to the valve assembly. Also include the part name, the assembly drawing number, the balloon number and the quantity stated on the assembly drawing.

DeZURIK Service

DeZURIK service personnel are available to install, maintain and repair all DeZURIK products. DeZURIK also offers customized training programs and consultation services.

For more information, contact your local DeZURIK sales representative or visit our website at www.dezurik.com.

Table of Contents

Description - - - - -	4
Air Supply - - - - -	4
Lubrication - - - - -	4
Actuator Identification - - - - -	4
Adjusting Position Stops	
<i>Adjusting the Open Position Stop</i> - - - - -	5
<i>Adjusting the Closed Position Stop</i> - - - - -	6
Removing Actuator - - - - -	6
Installing Actuator - - - - -	6
Removing Cylinder - - - - -	8
Installing Cylinder - - - - -	8
Disassembling Actuator - - - - -	9
Reassembling Actuator - - - - -	10
Changing Mounting Positions - - - - -	12
Troubleshooting - - - - -	12

Description

The G-Series Cylinder Actuator is a totally enclosed, quarter turn, pneumatic operated actuator.

Air Supply

The supply pressure to the cylinder should be between 50 and 100 psi (344 and 689 kPa).

Lubrication

The G-Series Cylinder Actuator has been lubricated at the factory and requires no routine lubrication. If the actuator is disassembled, lubricate the rack, rack guide, gear sector and bearings using one of these lubricants:

- Keystone Zeniplex-1 (**recommended**)
- Amoco Amolith Grease #1-EP (alternate)
- Amsoil GHD (alternate)
- Mobil Mobilux EP 1 (alternate)
- Petro-Canada Vultrex MPG EP 1 (alternate)
- Shell Alvania EP 1 (alternate)
- Texaco Multifak EP 1 (alternate)

If the cylinder is disassembled, it must be lubricated as described in the cylinder instructions.

Actuator Identification

The G-Series Cylinder Actuator is available in two sizes: 6A and 12A. See Figure 1 for actuator identification.

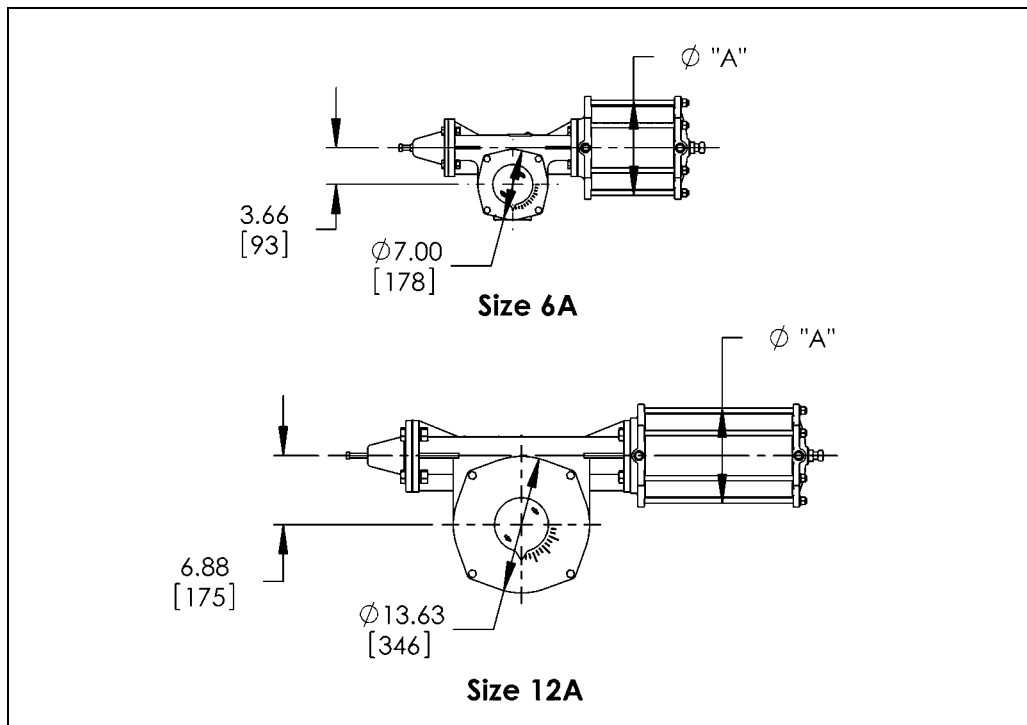

Figure 1 - Actuator Identification

To determine the actuator size, measure the diameter of the cover - see Figure 1. To determine the cylinder size, measure the diameter of the cylinder—see Figure 1 and Table A.

Actuator Identification (Continued)**Table A: Cylinder Identification**

Cylinder	Ø "A"	
	IN	MM
C4	4.5	115
C6	6.5	165
C8	8.5	215
C10	10.5	265

Adjusting Position Stops

The G-Series Cylinder Actuators have both open and closed position stops. See Figure 2 for position stop identification.

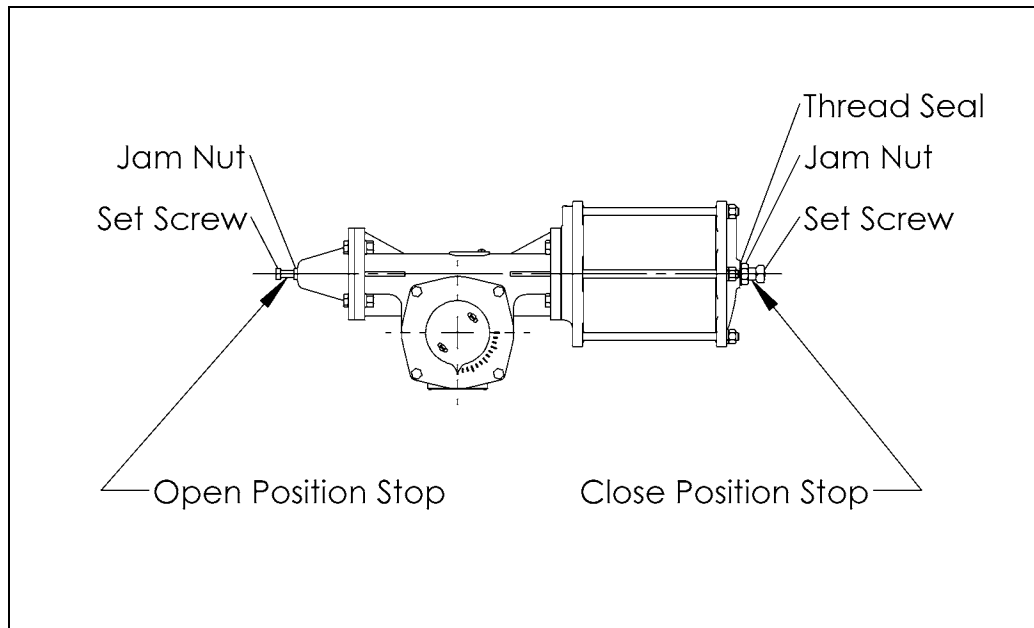
**Figure 2 – Position Stops**

The position stops are factory set and do not require adjustment unless the actuator has been disassembled or actuator orientation has been changed.

Adjusting the Open Position Stop

On 6A and 12A cylinder actuators, the Open Position Stop is located in the end of the extension cap opposite the cylinder. See Figure 2.

The actuator must be mounted before adjusting the position stop.

1. Loosen the Open Position jam nut.
2. Adjust the Open Position screw to the proper position. Counterclockwise rotation of screw increases the stroke, clockwise rotation of screw decreases the stroke.
3. Lock the Open Position screw in place with the jam nut.

Adjusting Position Stops *(Continued)*

Adjusting Closed Position Stop

On 6A and 12A cylinder actuators, the Closed Position Stop is located in the end of the cylinder. See Figure 2.

The actuator must be mounted before adjusting the position stop.

1. Loosen the Closed Position jam nut.
2. Adjust the Close Position screw to the proper position. Counterclockwise rotation of screw increases the stroke, clockwise rotation of screw decreases the stroke.
3. Lock the Closed Position screw in place with the jam nut.

NOTE: Make sure the thread seal is positioned properly, and lock the setscrew in place with the jam nut.

Removing Actuator

1. Discontinue flow, relieve pipeline pressure and close valve.



WARNING!

Accidental operation of power actuator can cause personal injury or equipment damage. Disconnect and lock out power to actuator before servicing.

2. Disconnect and lock out the pneumatic power to prevent accidental operation of the actuator.
3. Scribe corresponding lines on the valve and actuator to help align them during installation.
4. Remove screws (P4) and lockwashers (P10) and lift actuator assembly off adaptor (P1). See Figure 4 for connecting parts identification.

Installing Actuator

1. Line up the scribe marks on the valve and actuator made during actuator removal, then set the actuator on the valve so that the valve shaft slides into the actuator gear sector.
2. Fasten the actuator assembly to the adaptor plate (P1) with lockwashers (P3) and screws (P2). See Figure 4 for connecting parts identification.
3. Place the key into the key slot in the valve shaft and gear.
4. Secure key by staking with a center-punch on the end of the shaft. Stake on both sides of the shaft as shown in Figure 3.

Note: Do not deform the outside diameter of the shaft.

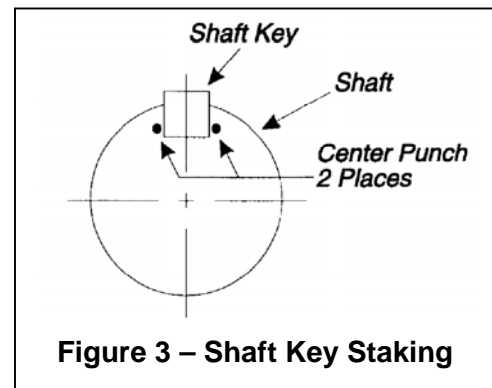

Figure 3 – Shaft Key Staking

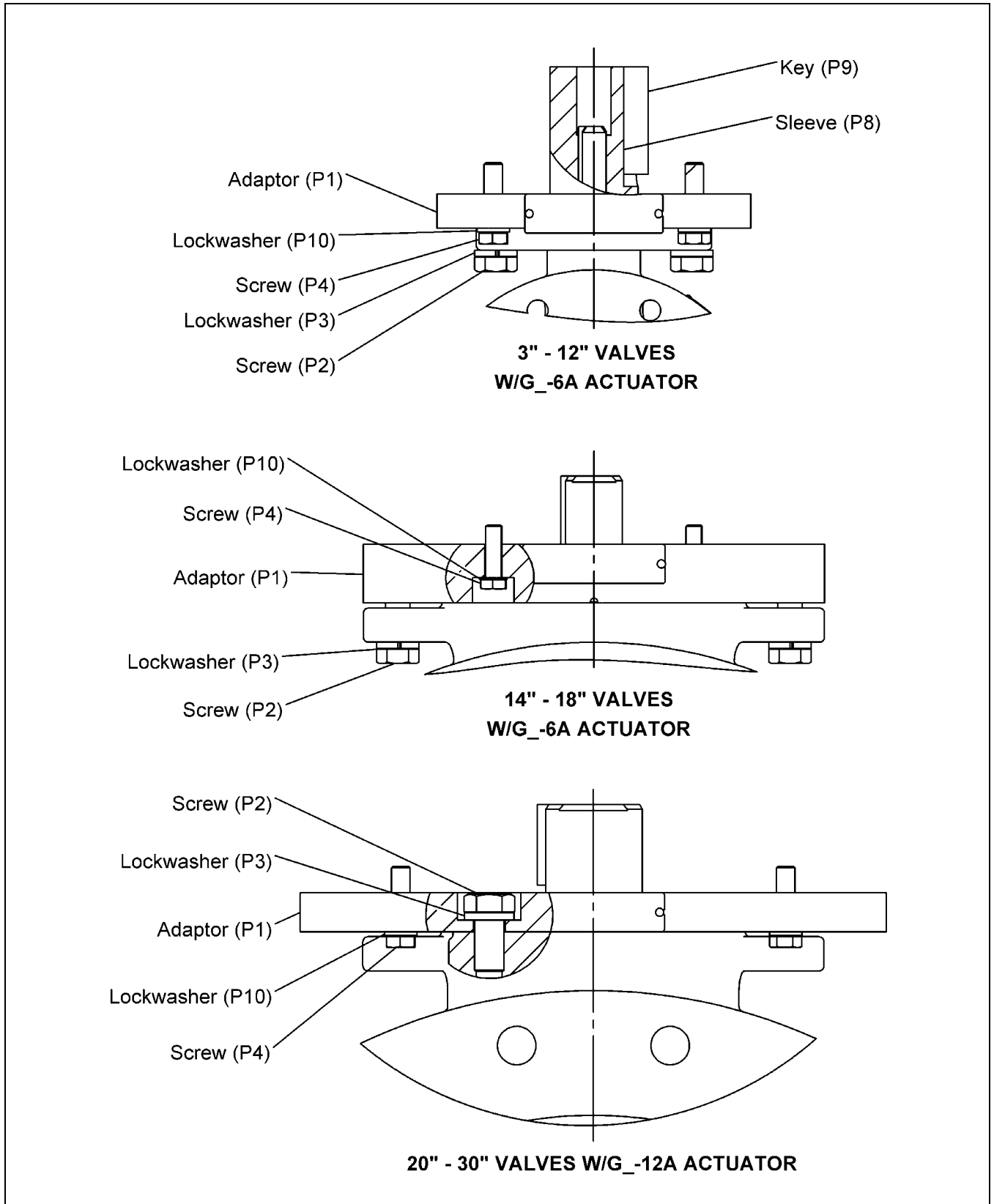

Figure 4 – Connecting Parts Identification

Removing Cylinder

This procedure can be performed with the actuator installed on the valve or removed.

1. Discontinue flow and relieve pipeline pressure.
2. Apply air pressure to the port in the cylinder cap (the end farthest from the actuator housing) until the valve has moved to the end of its stroke.



WARNING!

Accidental operation of power actuator can cause personal injury or equipment damage. Disconnect and lock out power to actuator before servicing.

3. Disconnect and lock out the pneumatic power to prevent accidental operation of the actuator.
4. Disconnect the tubing from both cylinder ports.
5. Remove the screws (B23), nuts (B24), lockwashers (B28) and stop cap (B29) from the housing (B1).
6. Remove the cap nut (B25), jam nut (B22) and spacer (B21) from the end of the rack rod (B6).
7. Remove the screws (B27) fastening the cylinder assembly to the housing (B1), and carefully remove the cylinder assembly by sliding it away from the actuator until the rack rod clears the housing.
8. See Cylinder Instructions for details on rebuilding the cylinder.

Installing Cylinder

1. Scrape the old gasket material from the actuator housing and cylinder head, then place a new gasket on the cylinder head.
2. Install the cylinder/rack rod assembly by sliding the rack rod through the rack (B4) and fasten the cylinder to the housing (B1) with screws (B27).

NOTE: If the rack rod is not attached to the cylinder assembly, clean the threads of both the rack rod and the cylinder shaft, then apply Loctite to the cylinder shaft threads and screw the rack rod onto the cylinder shaft.

3. Slide the spacer (B21) and nuts onto the rack rod.
4. Screw the jam nut (B22) onto the rack rod (B6) until spacer is tight against rack (B4).
5. Screw the cap nut (B25) onto the rack rod (B6) and tighten the two nuts against each other.
6. Apply a thin bead of silicone sealant Dow RTV-732 to the stop cap (B29) and attach it to the housing (B1) with screws (B23), nuts (B24) and lockwashers (B28).
7. Scrape old gasket material from the housing (B1) and stop cap (B29).
8. Apply a thin bead of silicone sealant Dow RTV-732 to the stop cap (B29) and attach it to the housing (B1) with screws (B23), nuts (B24) and lockwashers (B28).
9. If the actuator is a powered actuator, reconnect power to the actuator.
10. Adjust the open and closed position stops described in the “*Adjusting Position Stops*” section.

Disassembling Actuator

See Figure 5 for actuator parts identification.

1. Discontinue flow and relieve pipeline pressure and place the actuator in the open position.



WARNING!

Accidental operation of power actuator can cause personal injury or equipment damage. Disconnect and lock out power to actuator before servicing.

2. Disconnect and lock out the pneumatic power to prevent accidental operation of the actuator. Disconnect the tubing from the cylinder.
3. Remove the screws (B23), nuts (B24), lockwashers (B28) and stop cap (B29) from the actuator housing (B1).
4. Remove the cap nut (B25), jam nut (B22) and spacer (B21) from the end of the rack rod (B6).
5. Remove the screws (B27) fastening the cylinder assembly to the actuator housing (B1), and carefully remove the cylinder assembly and rack rod (B6) by sliding it away from the actuator until the rack rod clears the actuator housing.
6. Remove the screws (B18) fastening the pointer to the gear (B3) and remove pointer.
7. Scribe corresponding lines on the cover (B2) and housing (B1) to be used for alignment during assembly, then remove the screws (B13) fastening the cover to the housing and remove cover.
8. Remove the rack (B4) and gear (B3) from the housing (B1).
9. Remove screws (P4) and lockwashers (P10) and lift actuator assembly off valve. See Figure 3 for connecting parts identification.
10. Remove the rack bearing (B7) (if noticeable wear to bearing) by driving the pin (B11) out of the rack bearing and housing (B1).

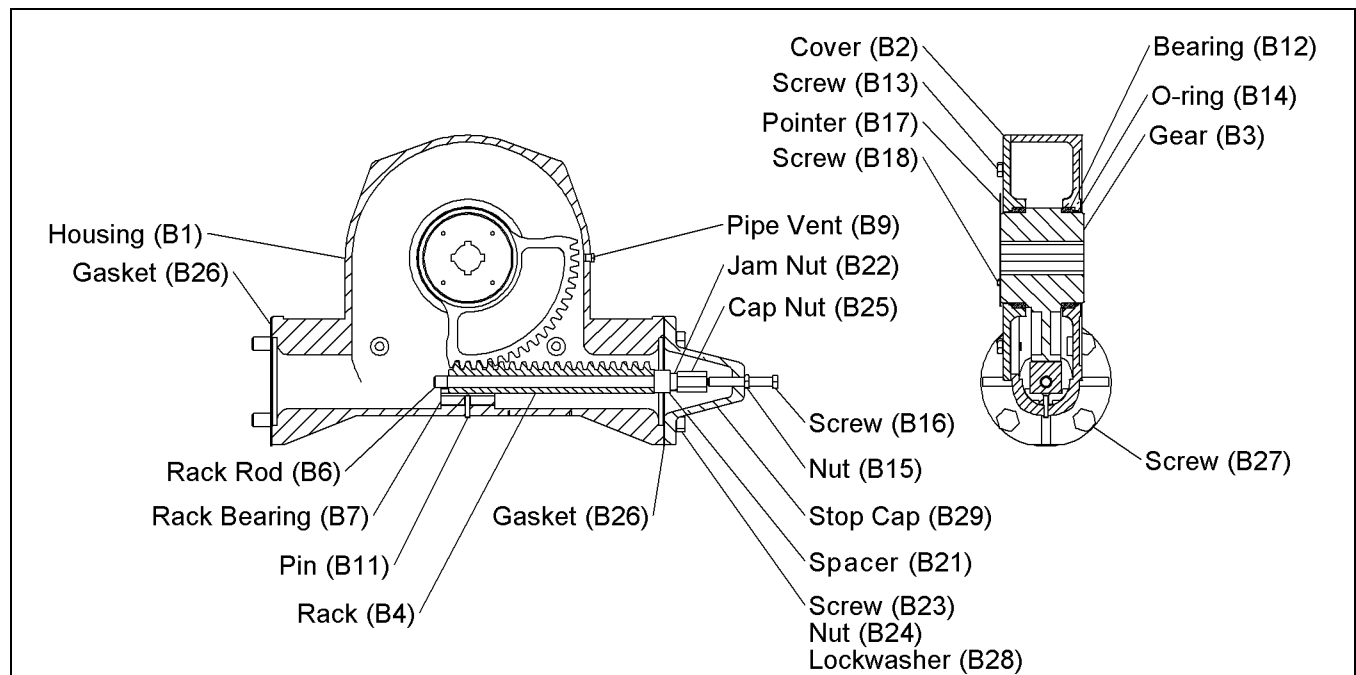

Figure 5 – Actuator Parts Identification

Reassembling Actuator

Install new bearings (B12) and O-rings (B14) in the housing (B1) and cover (B2) if necessary. See Figure 6 for proper placement.

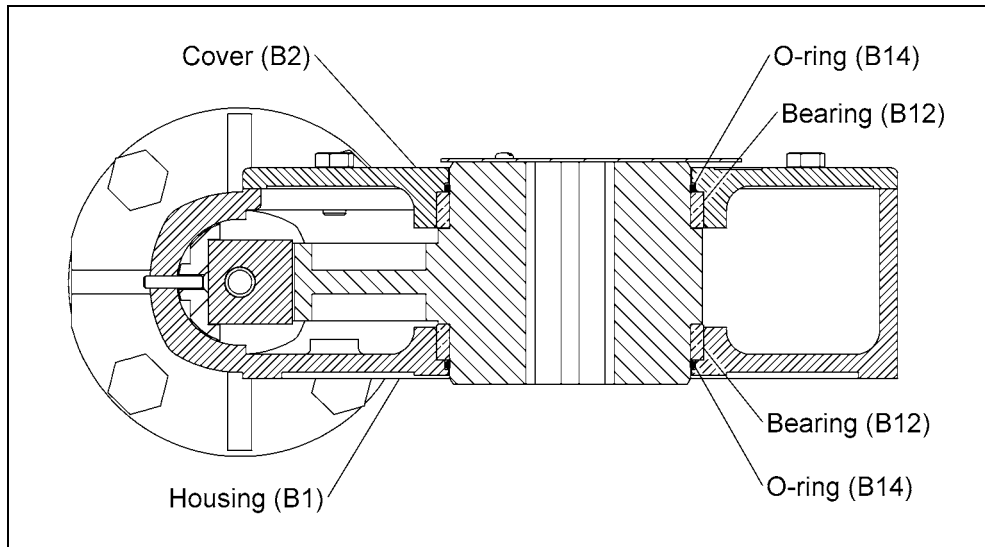
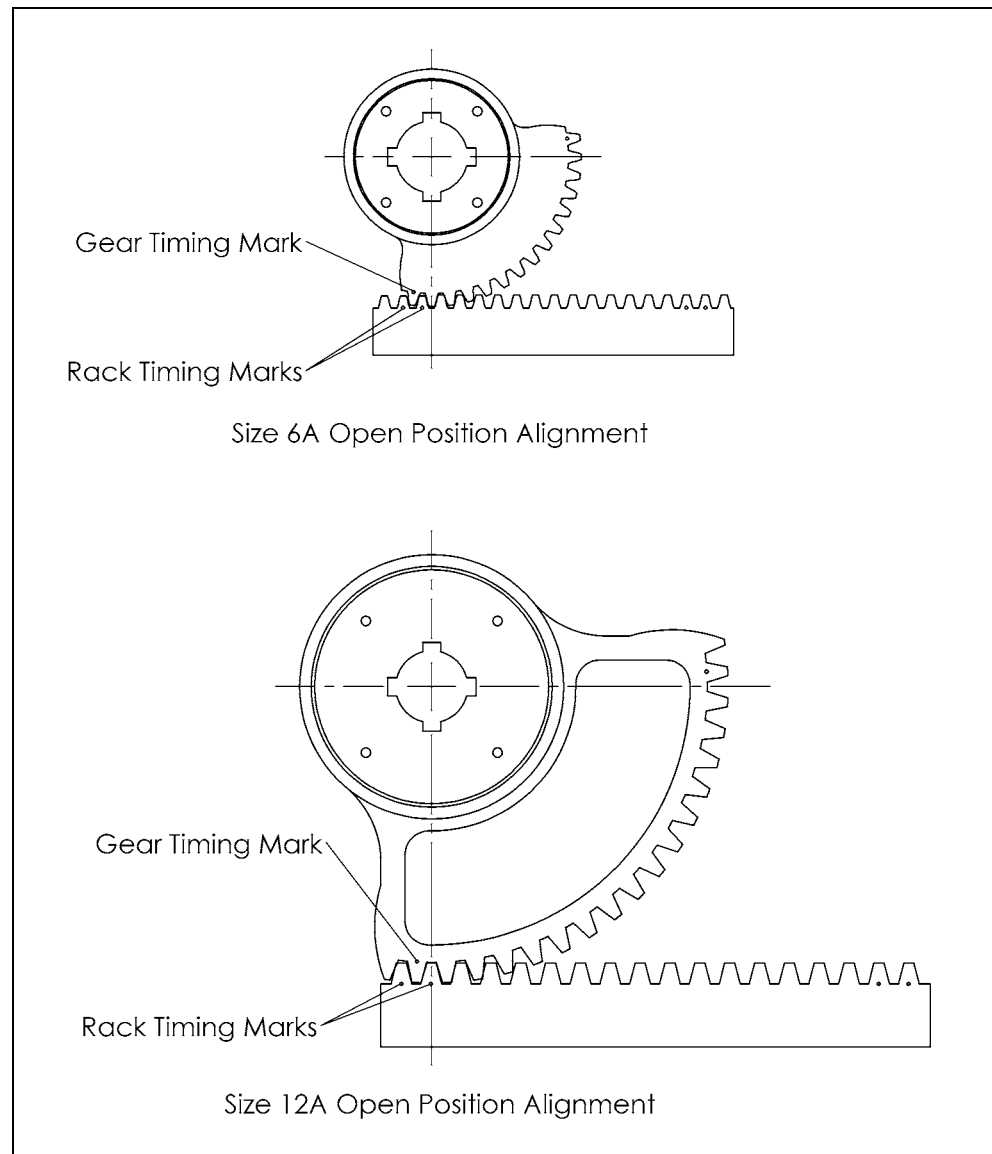

Figure 6 – Bearing and O-ring Locations

1. Scrape old gasket material from the housing (B1), cover (B2) and stop cap (B29).
2. Line up the scribe marks on the adaptor plate (P1) and actuator housing (B1) made during actuator removal, then set the actuator housing on the adaptor plate.
3. Fasten the actuator housing (B1) to the adaptor plate (P1) using screws (P4) and lockwashers (P10).
4. Drive the pin (B11) through the rack bearing (B7) and housing (B1) (**if worn rack bearing was removed**).
5. Apply a liberal amount of lubricant to the teeth and back of the rack (B4) which contacts the rack bearing (B7) and install the rack in the housing (B1).
6. Apply a liberal amount of lubricant to the teeth and journals of the gear (B3), then place the gear in the housing (B1) and carefully align the teeth with the rack as shown in Figure 7.

NOTE: It may be necessary to loosen the adapter mounting screws and move the housing a small amount to align the gears. Be sure to retighten the mounting screws after aligning the gears.

Reassembling Actuator (Continued)**Figure 7 – Gear and Rack Alignment**

7. Place a new gasket (B26) on the cylinder head.
8. Install the cylinder/rack rod assembly by sliding the rack rod through the rack (B4) and fasten the cylinder to the housing (B1) with screws (B27).

NOTE: If the rack rod is not attached to the cylinder assembly, clean the threads of both the rack rod and the cylinder shaft, then apply Loctite to the cylinder shaft threads and screw the rack rod onto the cylinder shaft.

9. Slide the spacer (B21) onto the rack rod (B6) and screw the jam nut (B22) onto the rack rod (B6) until the spacer is tight against the rack (B4).
10. Screw the cap nut (B25) onto the rack rod (B6) and tighten the two nuts against each other.

Reassembling Actuator *(Continued)*

11. Apply a thin bead of silicone sealant Dow RTV-732 to the stop cap (B29) and attach it to the housing (B1) with screws (B23), nuts (B24) and lockwashers (B28).
12. Apply a thin bead of silicone sealant Dow RTV-732 to the cover (B2). Line up the scribe marks on the cover and housing (B1) and attach the cover with screws (B13).
13. Attach the pointer (B17) to the gear (G3) with screws (B18) pointing to the open position mark on the cover (B2).
14. Adjust the open and closed position stops described in the “*Adjusting Position Stops*” section.

Changing Mounting Positions

The actuator can be mounted in 90° increments around the valve shaft.

1. Discontinue flow, relieve pipeline pressure and close valve.

**WARNING!**

Accidental operation of power actuator can cause personal injury or equipment damage. Disconnect and lock out power to actuator before servicing.

2. Remove the actuator from the valve. See “*Removing Actuator*” section.
3. Rotate the actuator to the desired position.
4. Install the actuator on the valve. See “*Installing Actuator*” section.

Troubleshooting

Condition	Possible Cause	Corrective Action
Actuator closes to wrong position	Closed position stop is set incorrectly	Adjust closed position stop. See <i>Adjusting Position Stops</i> section
Actuator opens to wrong position	Open position stop is set incorrectly	Adjust open position stop. See <i>Adjusting Position Stops</i> section
Actuator will not fully operate valve	Cylinder pressure is low	Increase cylinder pressure. Do not exceed 100 psi (69 kPa).
	Piston seal in cylinder is leaking	Replace piston seal(s). See Cylinder instructions.
	Pipeline obstruction in valve is preventing closure	Remove obstruction
Actuator rotates wrong direction	Air connections to cylinder are incorrect	Reverse air connections to cylinder