



**ANSI/AWWA C540
PNEUMATIC CYLINDER
FOR T-SERIES ACTUATORS**

DeZURIK

ANSI/AWWA C540 Pneumatic Cylinder for T-Series Actuators

Instructions

These instructions provide information about ANSI/AWWA C540 Pneumatic Cylinders. They are for use by personnel who are responsible for installation, operation and maintenance of ANSI/AWWA C540 Pneumatic Cylinders.

Safety Messages

All safety messages in the instructions are flagged with an exclamation symbol and the word Caution, Warning or Danger. These messages indicate procedures that must be followed exactly to avoid equipment damage, personal injury or death.

Safety label(s) on the product indicate hazards that can cause equipment damage, personal injury or death. If a safety label becomes difficult to see or read, or if a label has been removed, please contact DeZURIK for replacement label(s).



WARNING!

Personnel involved in the installation or maintenance of valves should be constantly alert to potential emission of pipeline material and take appropriate safety precautions. Always wear suitable protection when dealing with hazardous pipeline materials. Handle valves which have been removed from service with the assumption of pipeline material within the valve.

Inspection

Your ANSI/AWWA C540 Pneumatic Cylinder has been packaged to provide protection during shipment, however, it can be damaged in transport. Carefully inspect the unit for damage upon arrival and file a claim with the carrier if damage is apparent.

Parts

Recommended spare parts are listed on the assembly drawing. These parts should be stocked to minimize downtime.

Order parts from your local DeZURIK sales representative, or directly from DeZURIK. When ordering parts, please include the 7-digit part number and 4-digit revision number (example: **999999R000**) located on the data plate attached to the valve assembly. Also include the part name, the assembly drawing number, the balloon number and the quantity stated on the assembly drawing.

DeZURIK Service

DeZURIK service personnel are available to install, maintain and repair all DeZURIK products. DeZURIK also offers customized training programs and consultation services.

For more information, contact your local DeZURIK sales representative or visit our website at www.dezurik.com.

Table of Contents	Description	2
	Supply	2
	Tools Required	2
	Lubrication	2
	Adjustment	2
	Disassembly	2
	Reassembly	3

DeZURIK

ANSI/AWWA C540 Pneumatic Cylinder for T-Series Actuators

Description The ANSI/AWWA C540 Pneumatic Cylinder, for use with T-Series Actuators, is a Double Acting Cylinder intended for compressed air service.

Supply The maximum cylinder supply pressure is 150 psi. For maximum cylinder life, the air should be filtered and dry.

Tools Required The cylinder is assembled with SAE fasteners. Tools required for adjustment and disassembly include a set of combination wrenches, a flat-tipped screwdriver and a small hammer.



WARNING!

This cylinder is a pressure vessel. Supply pressure must be disconnected from the cylinder and the cylinder completely relieved of pressure before disassembling the cylinder. Failure to release pressure may result in personal injury and/or damage to other equipment.

Lubrication If the cylinder is disassembled, lubricate the cylinder wall, piston seal, O-ring and O-ring groove using one of these lubricants.

- Dow Corning Molykote No. 44 (**recommended**)
- Shell Retinax AM (alternate)
- Shell Lithall MDS (alternate)

Adjustment The set screw in the end of the cylinder is used to limit the cylinder stroke.

1. Pressurize the cylinder port nearest the actuator housing, closing the valve.
2. Relieve cylinder pressure. See Valve Instructions to determine closed position.
3. Loosen the lock nut and turn the set screw in the end of the cylinder in or out until the valve is in the correct closed position.
4. Reapply cylinder pressure to the port nearest the actuator housing, closing the valve, to ensure that stop is correctly set.
5. Lock the set screw in place with the nut. Be sure the thread seal is in place.

Disassembly

1. Shut off the air supply to the cylinder and relieve the pressure in the cylinder.
2. If the actuator is powered, disconnect and lock out the pneumatic, hydraulic, or electrical power to prevent accidental operation of the actuator.



WARNING!

Moving parts from accidental operation of power actuator can cause personal injury or equipment damage. Disconnect and lock out power to actuator before servicing.

3. Disconnect the tubing from the cylinder.
4. Remove nuts and washers from the tie rods, and remove cylinder cap.

Disassembly
(Continued)

5. Remove O-ring from cylinder cap.
6. Rotate the cylinder tube while pulling it off the piston.
7. Remove the tie rods from the cylinder head.
8. Remove the nut on the piston rod.
9. Remove the piston
10. Remove piston seal and O-ring from piston.
11. Remove the four screws that fasten the cylinder head to the actuator housing, then slide the cylinder head off the piston rod.
12. Remove the rod seal and O-ring from the cylinder head.

Reassembly

1. Lubricate, then install the piston rod seal as shown in Figure 1. The backup rings are cut with a bevel; be sure the ends match up and do not overlap.

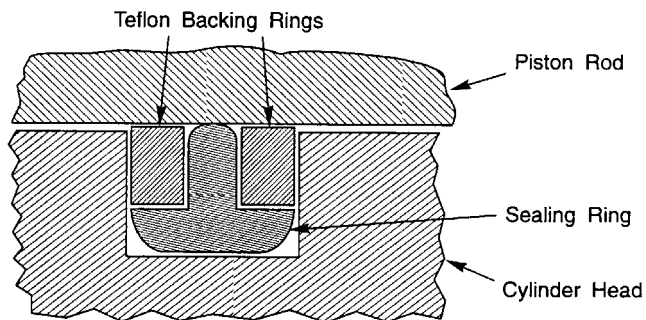

Figure 1 –Piston Rod Seal and O-ring Placement

2. Carefully slide the cylinder head over the piston rod until it contacts the actuator housing. Fasten the cylinder head to the housing with the four screws removed earlier. See Figure 2.
3. Lubricate the small O-ring, then slide it into the counterbore in the piston.

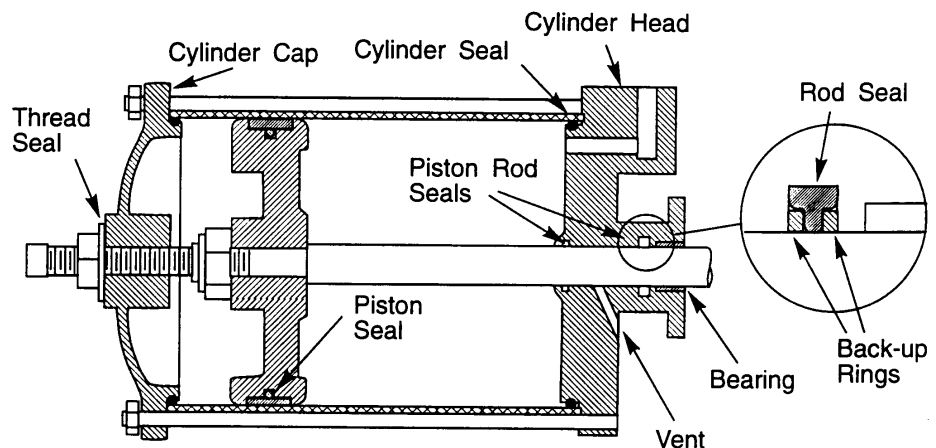

Figure 2 –Cylinder Parts Location

DeZURIK

ANSI/AWWA C540 Pneumatic Cylinder for T-Series Actuators

Reassembly (Continued)

- Slide the piston onto the piston rod so the O-ring in the piston faces the cylinder head.
- Install the nut to hold the piston in place and tighten the nut to 45 foot pounds.
- Lubricate the medium sized O-ring, then stretch it onto the piston until it fits in the groove.
- Lubricate the piston seal, then slide it over the piston without stretching it any more than necessary. The seal fits into the groove on top of the O-ring.
- Clean the O-ring groove in the cylinder head.
- Install one of the large O-rings in the groove in the cylinder head. Use a new O-ring if necessary.
- On 6 inch and larger cylinders, remove one or two of the tie rods.
- Lubricate the inside of the cylinder tube, then slide it onto the piston. Start the tube at a 45-degree angle and rotate the tube onto the piston. See Figure 3.

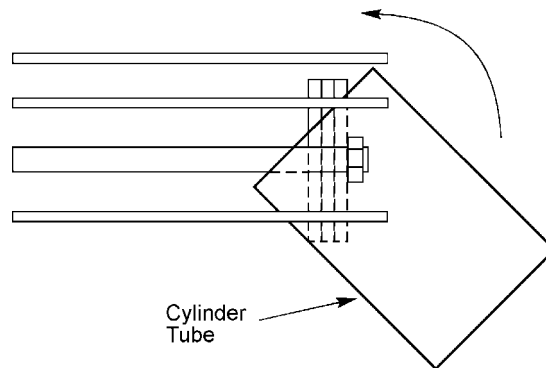

Figure 3—Installing Cylinder Tube

- Thread the tie rods into the cylinder head.
- Clean the O-ring groove in the cylinder cap.
- Lubricate, then install the other large O-ring in the groove in the cylinder cap. Use a new O-ring if necessary.
- Slide the cylinder cap over the tie rods and push it in until the O-ring slides into the cylinder tube.
- Assemble the cylinder cap, lock washers and nuts, and tighten tie rod nuts to the torque specified in Table A.
- Check the open and closed position stops and readjust if necessary. See the CLOSED POSITION ADJUSTMENT section of these instructions and the OPEN POSITION ADJUSTMENT section of the Actuator Instructions.
- If the actuator is powered, reconnect power to the actuator.

Reassembly
(Continued)

Table A: Tie Rod Nut Torques

Cylinder Size	Torque		
	(ft lbs)	(cm kg)	(Nm)
3" & 4"	12	175	16
6" & 8"	16	225	22
10" & 12"	20	275	27