



DeZURIK MANUAL
G-SERIES ACTUATORS
ON 100% AREA PEC ECCENTRIC VALVES

Instruction D10261
August 2011

Instructions

These instructions provide information about Manual G-Series Actuators. They are for use by personnel who are responsible for installation, operation and maintenance of Manual G-Series Actuators.

Safety Messages

All safety messages in the instructions are flagged with an exclamation symbol and the word Caution, Warning or Danger. These messages indicate procedures that must be followed exactly to avoid equipment damage, personal injury or death. Safety label(s) on the product indicate hazards that can cause equipment damage, personal injury or death.

Safety label(s) on the product indicate hazards that can cause equipment damage, personal injury or death. If a safety label becomes difficult to see or read, or if a label has been removed, please contact DeZURIK for replacement label(s).



WARNING!

Personnel involved in the installation or maintenance of valves should be constantly alert to potential emission of pipeline material and take appropriate safety precautions. Always wear suitable protection when dealing with hazardous pipeline materials. Handle valves, which have been removed from service with suitable protection for any potential pipeline material in the valve.

Inspection

Your Manual G-Series Actuator has been packaged to provide protection during shipment, however, it can be damaged in transport. Carefully inspect the unit for damage upon arrival and file a claim with the carrier if damage is apparent.

Parts

Recommended spare parts are listed on the assembly drawing. These parts should be stocked to minimize downtime.

Order parts from your DeZURIK sales representative, or directly from DeZURIK. When ordering parts, please include the 7-digit part number and 4-digit revision number (example: **9999999R000**) located on the data plate attached to the valve assembly. Also include the part name, the assembly drawing number, the balloon number and the quantity stated on the assembly drawing.

DeZURIK Service

DeZURIK service personnel are available to install, maintain and repair all DeZURIK products. DeZURIK also offers customized training programs and consultation services.

For more information, contact your local DeZURIK sales representative or visit our website at www.dezurik.com.

Table of Contents

Description - - - - -	4
Operation - - - - -	5
Tools Required - - - - -	5
Lubrication - - - - -	5
Stop Adjustments - - - - -	6
Actuator Removal - - - - -	7
Actuator Installation- - - - -	9
Removing Valve from Pipeline - - - - -	10
Recommended Spare Parts Replacement - - - - -	10
Changing Actuator Mounting Position - - - - -	13

Description

The manual operated G-Series actuator is designed to operate a PEC Eccentric valve. Integral stops limit actuator stroke for both the open and closed valve positions. This actuator is available in three sizes: Size 6, Size 12 and Size 16. See Figure 1 to identify which unit you have.



CAUTION!

This actuator can be furnished with either cast iron or ductile iron gears.

The ductile iron gear is necessary for submerged or buried service valves or when a 2" operating nut is installed on the input shaft. Breakage of the gear teeth will occur if cast iron gears are torqued above 200 ft-lb's.

Cast Iron & Ductile Iron are similar in appearance: To determine if the gear material is ductile iron, remove the cover as described in the ACTUATOR DISASSEMBLY Section. Size 6 gears have "M199" cast in raised letters on the round surface opposite the teeth. Size 12 & Size 16 gears have "M199" cast in raised letters on either the top or under side of the web between the hub and the teeth, removal of the gear is necessary to see the marking. If there is no "M199" on the gear, the material is cast iron.

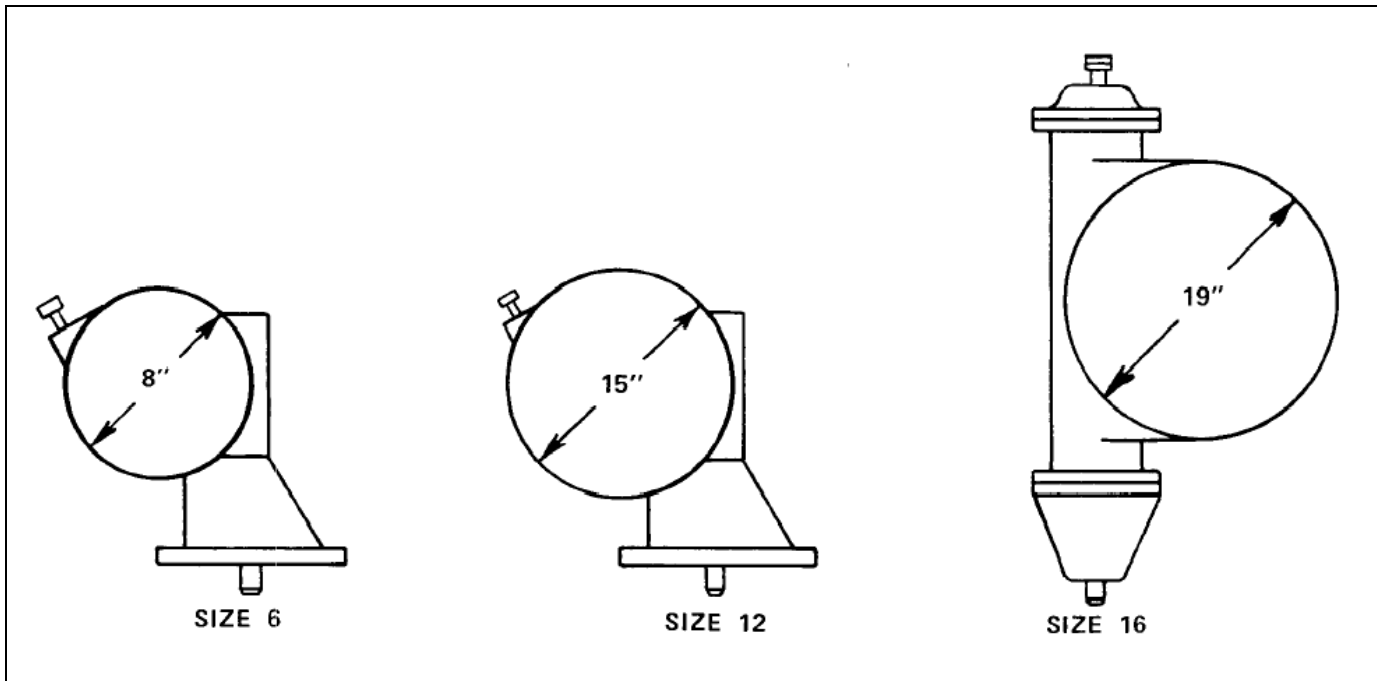

Figure 1— G-Series Actuator Identification

Operation

Rotating the operator (handwheel or chainwheel) clockwise closes the valve. To actuate the valve from full open to full closed (or vice-versa), the Size 6 requires 13 revolutions, the Size 12 requires 19 revolutions and the Size 16 requires 33 revolutions of the operator.

Tools Required

This actuator is assembled using only standard SAE fasteners. To service this unit, you should have a full set of combination wrenches, Allen wrenches, flat tipped screwdrivers, a pin punch and a dead blow hammer.

Lubrication

The Manual G-Series Actuator has been lubricated at the factory and requires no routine maintenance lubrication. If the actuator is disassembled, apply a liberal amount of lubricant using one of these lubricants:

- Keystone Zeniplex-1 (**recommended**)
- Amoco Amolith Grease #1-EP (alternate)
- Amsoil GHD (alternate)
- Mobil Mobilux EP 1 (alternate)
- Petro-Canada Vultrex MPG EP 1 (alternate)
- Shell Alvania EP 1 (alternate)
- Texaco Multifak EP 1 (alternate)

Size 6 and Size 12 Actuators - Apply lubricant to the bearings, gear sector teeth and worm gear.

Size 16 Actuators - Apply lubricant to the bearings, gear sector teeth, rack teeth. And rack guide.

Stop Adjustments

This actuator has a stop to limit valve stroke at each end of the cycle. The open position stop is an integral, non-adjustable stop in the actuator cover; the closed position stop is an adjustable stop screw located in the side of the actuator housing (Size 6 and Size 12) or in the end of the extension cap (Size 16). To adjust the closed position stop follow these steps:

1. Relieve pipeline pressure.
2. Loosen the jam nut on the closed position stop screw, then turn the closed position stop screw counterclockwise about 1 1/2".
3. Close the valve with the torque specified in Table A.
4. While maintaining the torque from Table A, turn the closed position stop adjusting screw in just until resistance is felt as it contacts the gear.
5. Lock the stop in this position by tightening the jam nut against the actuator.

Table A: Valve Closing Torques

Valve Size	Actuator Size	Seating Torque (ft lbs)									
		Direct Pressure Drop (psi)	Reverse Pressure Drop								
			25	50	75	100	125	150	175	200	230
0350	G6	4	4	4	5	5	5	5	5	5	5
0450	G6	8	8	9	10	11	11	11	11	11	11
0650	G6	15	15	17	19	20	21	21	21	21	21
0850	G6	22	22	25	29	33	36	N/A	N/A	N/A	N/A
0850	G12	11	11	18	18	18	18	18	18	18	18
1050	G6	29	29	29	29	N/A	N/A	N/A	N/A	N/A	N/A
1050	G12	15	15	15	15	15	15	15	15	15	15
1250	G12	18	18	24	29	34	34	34	34	34	34
1450	G12	22	22	29	37	45	45	45	45	N/A	N/A
1450	G16	19	19	26	26	26	26	26	26	26	26
1650	G12	26	26	35	45	55	55	N/A	N/A	N/A	N/A
1650	G16	21	21	29	29	29	29	29	29	29	29
1850	G12	29	29	44	55	55	N/A	N/A	N/A	N/A	N/A
1850	G16	22	22	32	32	32	32	32	32	32	32
2050	G16	24	24	29	34	39	N/A	N/A	N/A	N/A	N/A

Note: The "N/A" designation in Table A indicates that the Valve/Actuator combination cannot be used for that particular reverse pressure.

Stop Adjustments *(continued)*

Direct Pressure - When the higher pressure is at the end opposite the seat. See Figure 2.

Reverse Pressure - When the higher pressure is at the seat end of the valve. See Figure 2.

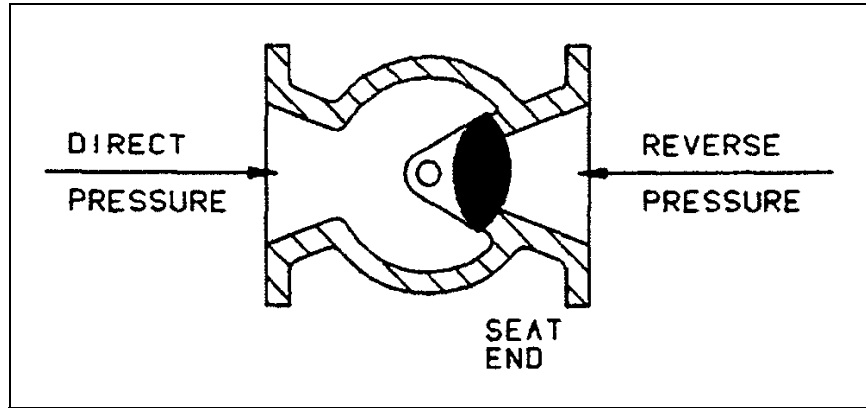

Figure 2— Pressure Direction

Actuator Removal

The actuator removal procedure is dependent upon whether or not the actuator is built for submerged service. Follow the correct section to properly and safely remove the actuator.

**WARNING!**

When Eccentric valves are mounted in a vertical pipeline, or mounted in a horizontal pipeline with the plug stem horizontal, there is a chance that gravity will cause the plug to swing to a lower position in the valve body when the actuator is removed. To avoid this hazard, place the plug in the lowest position before removing the actuator.

Submerged Service Actuators

1. Discontinue flow and relieve pipeline pressure.

**WARNING!**

The valve is a pressure vessel. Pressure must be completely released before removing the bonnet bolts on the 0350, 0450 and 0850 valves.

2. Scribe corresponding lines on the valve and actuator to be used for alignment during actuator installation.
3. Scribe corresponding lines on the actuator housing and top cover so the cover can be reinstalled in the correct position.

Actuator Removal *(continued)*

4. Remove the screws attaching the top cover on the actuator and lift the cover from the housing.
5. If the valve is a size 0350 thru 1850, remove the lock nut, spring washers and flat washers from the plug stud and go to Step 9. If the valve is a size 2050, do not remove anything, go to the next step.
6. Loosen lockscrew #1 about 6 to 8 turns. Loosen lockscrews #2 about 3 turns. See Figure 3.

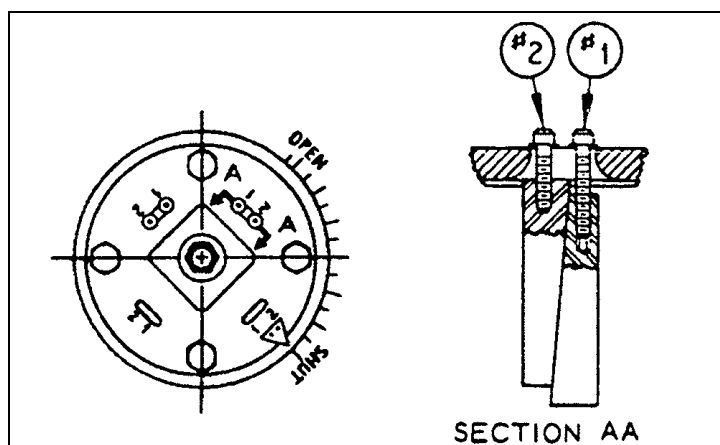

Figure 3— 2050 Key and Lockscrew Arrangement

7. Using a soft hammer, tap the heads of the #1 lockscrews to loosen the keys.
8. Remove the four screws holding the washer to the gear sector, then remove the stud, locknut, spring washers and the washer with the keys attached.
9. Remove the 6 screws fastening the adaptor to the valve. On the 0350, 0450 and 0850 valves, these screws also hold the bonnet to the valve body.
10. Lift the actuator and adaptor off the valve.
11. Scrape the old gasket material from the valve bonnet and the bottom of the adaptor.
12. Scrape the gasket material from the actuator cover and housing.

Non-Submerged Service Actuators

1. Discontinue flow and relieve pipeline pressure.

**WARNING!**

The valve is a pressure vessel. Pressure must be completely released before removing the bonnet bolts on the 0350, 0450 and 0850 valves.

2. Scribe corresponding lines on the valve and actuator to be used for alignment during actuator installation.
3. If the valve is a size 0350 thru 1850, remove the lock nut, spring washers, wrenching nut and pointer from the plug stud, then go to Step 7. If the valve is a size 2050, do not remove anything and go to the next step.

Actuator Removal *(continued)*

4. Loosen lock screw #1 about 6 to 8 turns. Loosen lock screws #2 about 3 turns. See Figure 3.
5. Using a soft hammer, tap the heads of the #1 lock screws to loosen the keys.
6. Remove the four screws holding the wrenching nut to the gear sector, then remove the stud, locknut, spring washers and the wrenching nut with the keys attached.
7. Remove the 6 screws fastening the adaptor to the valve. On the 0350, 0450 and 0850 valves, these screws also hold the bonnet to the valve body.
8. Lift the actuator and adaptor off the valve.

Actuator Installation

The actuator installation procedure is dependent upon whether or not the actuator is built for submerged service. Follow the correct section to properly install the actuator.

Submerged Service Actuators

1. Place the valve in the position it was in when the actuator was removed. Normally this will be so the plug is in the lowest position in the valve body.
2. Place a new gasket on the valve bonnet, lining up the holes in the bonnet and gasket.
3. Line up the scribe marks on the valve and actuator made during actuator removal, then set the actuator on the valve so the valve shaft slides into the actuator gear sector.
4. Fasten the actuator adaptor to the valve with six screws.
5. Slide the flat washer down the plug stud so it rests on top of the gear sector. If the valve is a size 2050, hold the keys in position when you slide the washer over the plug stud and guide the keys into the gear sector and stem slots. Then install the four screws fastening the washer to the gear sector.
6. Place the spring washers on the plug stud as shown in Figure 4.

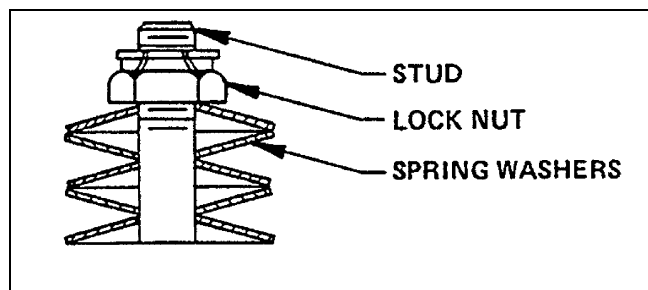

Figure 4—Spring Washer Stackup

7. Screw the lock nut down the plug stud until it is tight and the spring washers are completely compressed, then back the nut off one full turn.
8. If the valve is a size 2050, tighten the #2 lock screws and then the #1 lock screws to hold the keys in place. Skip this step if the valve is a size 0350 thru 1850.
9. Line up the scribe marks on the cover and housing, then set the cover on the actuator. Fasten the cover in place.
10. Check the closed position stop setting and readjust if necessary.
11. Pipeline flow may now be restored.

Actuator Removal *(continued)***Non-Submerged Service Actuators**

1. Place the valve in the position it was in when the actuator was removed. Normally this will be so the plug is in the lowest position in the valve body.
2. Line up the scribe marks on the valve and actuator made during actuator removal, then set the actuator on the valve so the valve shaft slides into the actuator gear sector.
3. Fasten the actuator adaptor to the valve with six screws.
4. Slide the pointer and wrenching nut down the plug stud so it rests on top of the gear sector; the pointer should point to indicate the correct valve position. If the valve is a size 2050, hold the keys in position when you slide the wrenching nut over the plug stud and guide the keys into the gear sector and stem slots. Then install the four screws fastening the wrenching nut to the gear sector.
5. Place the spring washers on the plug stud as shown in figure 4.
6. Screw the lock nut down the plug stud until the spring washers are completely compressed, then back the nut off until the washers return to their normal unstressed shape.
7. If the valve is a size 2050, tighten the #2 lockscrews and then the #1 lockscrews to hold the keys in place. Skip this step if the valve is a size 0350 thru 1850.
8. Pipeline flow may now be restored.

Recommended Spare Parts Replacement

Follow these steps to replace the recommended spare parts in this actuator. This procedure is dependent upon the actuator size (see Figure 1); make sure you are using the correct section for your actuator.

**WARNING!**

When Eccentric valves are mounted in a vertical pipeline, or mounted in a horizontal pipeline with the plug stem horizontal, there is a chance that gravity will cause the plug to swing to a lower position in the valve body when the actuator is removed. To avoid this hazard, place the plug in the lowest position before removing the actuator.

Size 6 and Size 12 Actuators

1. Remove the actuator from the valve as described in the ACTUATOR REMOVAL Section of this Instruction.
2. Scribe corresponding lines on the actuator cover and housing, then remove the cover screws and cover from the top of the actuator (non-submerged units).
3. Note the position of the gear sector in the housing, then lift the gear sector out.
4. Remove the pipe plug in the side of the housing.
5. Reaching in thru the hole where the pipe plug was, drive out the pin connecting the worm gear to the actuator drive shaft. Take the pin out of the housing.

Recommended Spare Parts Replacement *(continued)*

6. Slide the drive shaft (complete with operator) out of the actuator.
7. Reach into the housing and remove the worm gear, thrust bearing(s) and bearing races. The Size 6 actuator has one thrust bearing and two bearing races; the Size 12 has two bearings and four bearing races.
8. Remove the gear sector seals from the top cover and adaptor.
9. Remove the drive shaft seal from the housing.
10. Scrape the gasket material from the top cover and actuator housing.
11. Lubricate the new seals and press them into the top cover and adaptor.
12. Push a new drive shaft seal into the housing.
13. **Size 6 Actuators** - Slide the drive shaft into the housing and thru these components in the following order: bearing race, bearing, bearing race, worm gear, and then into the bearing in the housing.

Size 12 Actuators - Slide the drive shaft into the housing and thru these components in the following order: bearing race, bearing, bearing race, worm gear, bearing race, bearing, bearing race, and then into the bearing in the housing.
14. Turn the drive shaft and worm gear until the holes in them line up with the pipe plug hole in the housing.
15. Reaching in thru the pipe plug hole, insert the pin to connect the drive shaft and worm gear.
16. Screw the pipe plug into the hole in the housing.
17. Place the gear sector on the valve shaft in the same position noted before it was removed.
18. Apply a liberal amount of lubricant to the gear sector, bearings and worm gear.
19. Set a new cover gasket on the housing, then install and fasten the top cover on the housing; make sure the scribe marks line up (non-submerged units only).
20. Install the actuator on the valve as described in the ACTUATOR INSTALLATION Section of this Instruction.

Size 16 Actuators

1. Remove the actuator from the valve as described in the ACTUATOR REMOVAL Section of this Instruction.
2. Scribe corresponding lines on the actuator cover and housing, then remove the cover screws and cover from the top of the actuator (non-submerged units).
3. Note the position of the gear sector in the housing, then lift the gear sector out.
4. Mark one tooth on the rack with a center punch, then mark two adjacent teeth on the gear so the rack and gear can be re-installed in the correct position.
5. Remove the four screws that hold the drive shaft housing assembly to the actuator housing.
6. Turn the operator clockwise to remove the drive shaft housing assembly from the actuator housing.
7. Lift the gear sector and rack from the housing.

Recommended Spare Parts Replacement *(continued)*

8. Remove the rack guide from the pin in the housing.
9. Remove the gear sector seals from the top cover and adaptor.
10. Scrape the gasket material from the top cover, actuator housing and drive shaft housing.
11. Rebuild the drive shaft housing assembly as follows:
 - a. Remove the set screw inside the housing and turn the threaded collar out. The bearing and two bearing faces will also come out.
 - b. Remove the pin securing the operator to the drive shaft and slide the operator off the shaft.
 - c. Push the housing off the operator end of the drive shaft. The remaining bearing and two races will come out at this time.
 - d. Pull the seal out of the drive shaft housing.
 - e. Lightly lubricate the new seal and slide it into the drive shaft housing.
 - f. Sandwich the bearing between the two races and slide them down the operator end of the drive shaft until they sit on the sleeve.
 - g. Apply a liberal amount of lubricant to the bearing and races.
 - h. Carefully push the operator end of the drive shaft thru the seal from inside the housing.
 - i. Slide the operator onto the shaft, line up the holes in the operator and shaft, then install the pin.
 - j. Sandwich the bearing between the two races and slide them against the sleeve inside the housing.
 - k. Apply a liberal amount of lubricant to the bearings.
 - l. Screw the threaded collar into place and secure with the set screw.
12. Lubricate the new seals and press them into the top cover and adaptor.
13. Pin the rack guide in position in the housing.
14. Place the gear sector and rack in the housing, carefully aligning the teeth marked during disassembly.
15. Place a new gasket on the drive shaft housing, then push the drive shaft housing assembly into the actuator housing.
16. Turn the operator counterclockwise to screw the drive shaft into the rack until the drive shaft housing is tight against the actuator housing.
17. Fasten the drive shaft housing to the actuator housing with four screws.
18. Apply a liberal amount of lubricant to the gear sector and rack.
19. Set a new cover gasket on the housing, then install and fasten the top cover on the housing; make sure the scribe marks line up (non-submerged units only).
20. Install the actuator on the valve as described in the ACTUATOR INSTALLATION Section of this Instruction.

Changing Actuator Mounting Position

On 0350 thru 1850 valves the actuator can be mounted in 60° increments around the valve shaft. On 2050 valves the actuator can be mounted in 90o increments around the valve shaft.

To move the actuator mounting position in 60° increments from its present position on 0350 thru 1850 valves and 90° increments on 2050 valves, follow these steps.

1. Remove the actuator from the valve as described in the ACTUATOR REMOVAL Section of this Instruction.
2. Rotate the actuator to the desired position.
3. Install the actuator on the valve as described in the ACTUATOR INSTALLATION Section of this Instruction.