



POWERAC® CYLINDER ACTUATORS TECHNICAL SPECIFICATIONS



Materials of Construction

Item	Description	Material
B1	Housing	Cast Iron, ASTM A126 CL B
B2	Bearing	Bronze, ASTM B438
B3	Rack Bearing	Iron-Copper, ASTM B439-83 GR 4
B4	Pin	Zinc Plated Carbon Steel
B5	Rack	Nickel-Steel Powdered Metal, ASTM B783 FN-0208-80HT
B6	Lockwasher	Zinc Plated Carbon Steel
B7	Rack Screw	Zinc Plated Carbon Steel, SAE GR 5
B8	Gear	Nickel-Steel Powdered Metal, ASTM B783 FN-0208-80HT
B9	Square Collet Assembly	
B9A	Adjusting Screw	17-4PH Stainless Steel, ASTM 564 Type 6 Condition A
B9B	Wedge	17-4PH Stainless Steel, ASTM A747 Condition H900
B9C	O-Ring	Nitrile
B9D	Nut	18-8 Stainless Steel or 316 Stainless Steel
B9E	Lockwasher	18-8 Stainless Steel or 316 Stainless Steel
B9F	Pointer	Nickel Steel Powdered Metal, ASTM B783 FN-0208-80HT
B9G	Screw	18-8 Stainless Steel
B9H	Washer	18-8 Stainless Steel
B10	O-Ring	Nitrile
B11	Top Cover	Cast Iron, ASTM A126 CL B
B12	Bearing	Bronze, ASTM B438
B13	Gasket	Non-Asbestos Organic Fibers
B14	Washer	Zinc Plated Carbon Steel or 316 Stainless Steel
B15	Top Cover Screw	Zinc Plated Carbon Steel or 316 Stainless Steel
B16	Gasket	Non-Asbestos Organic Fibers
B17	End Cover	Cast Iron, ASTM A126 CL B
B18	Stud	Zinc Plated Carbon Steel or 316 Stainless Steel
B19	Lockwasher	Zinc Plated Carbon Steel or 316 Stainless Steel
B20	Nut	Zinc Plated Carbon Steel or 316 Stainless Steel
B21	Stop Screw	Zinc Plated Carbon Steel or 316 Stainless Steel
B22	Jam Nut	Zinc Plated Carbon Steel or 316 Stainless Steel
B24	Data Plate	302 Stainless Steel
B25	Drive Screw	Cadmium Plated Carbon Steel
C1	Cylinder Head	Cast Iron ASTM A126 CL B
C2	Bearing	Bronze, ASTM, B438-73
C3	Seal	PTFE-Nitrile

R1A & R2A

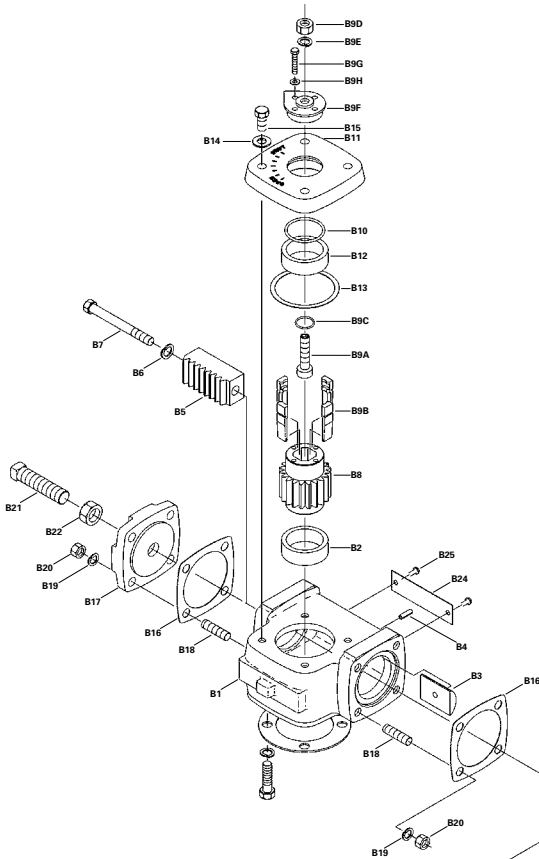

Double-Acting

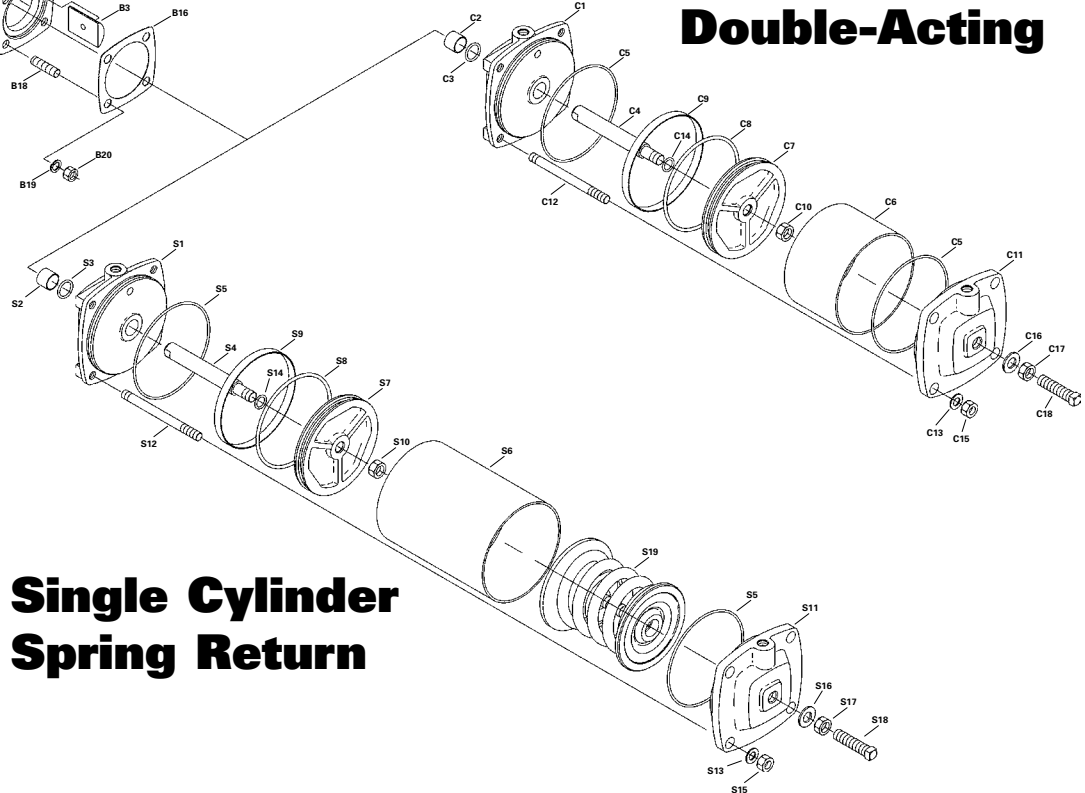

Single Cylinder Spring Return

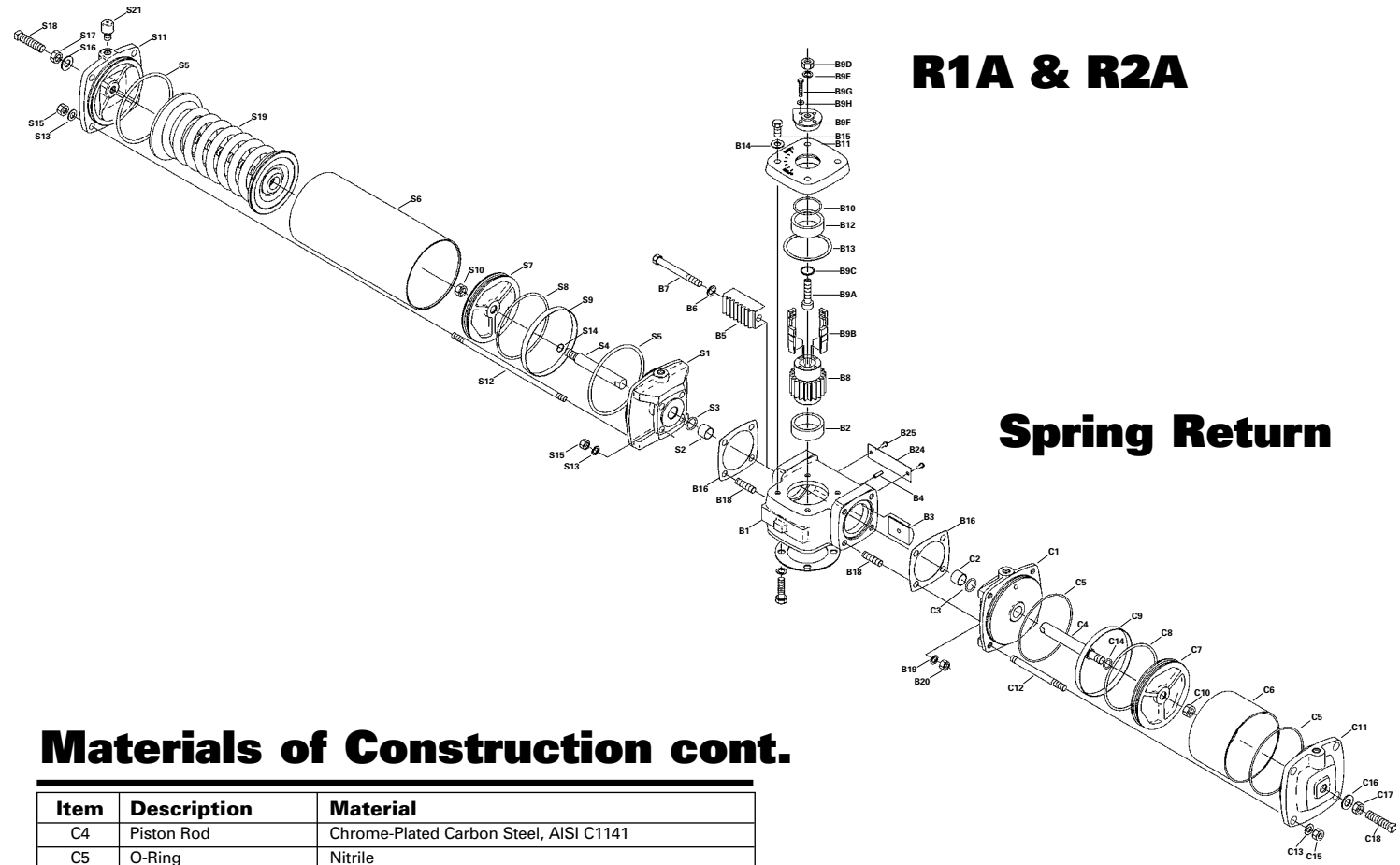

Materials of Construction cont.

Item	Description	Material
C4	Piston Rod	Chrome-Plated Carbon Steel, AISI C1141
C5	O-Ring	Nitrile
C6	Tube	Glass Filament Wound
C7	Piston	Cast Iron ASTM A126 CL B
C8	O-Ring	Nitrile
C9	Seal	PTFE
C10	Nut	Zinc Plated Carbon Steel
C11	Cylinder Cap	Ductile Iron, ASTM A536 65-45-12
C12	Tie Rod	Zinc Plated Carbon Steel or 316 Stainless Steel
C13	Washer	Zinc Plated Carbon Steel or 316 Stainless Steel
C14	O-Ring	Nitrile
C15	Nut	Zinc Plated Carbon Steel or 316 Stainless Steel
C16	Thread Seal	Steel and Nitrile
C17	Jam Nut	Zinc Plated Carbon Steel or 316 Stainless Steel
C18	Set Screw	Zinc Plated Carbon Steel or 316 Stainless Steel
S1	Cylinder Head	Cast Iron, ASTM A126 CL B
S2	Bearing	PTFE Fabric with Cadmium Plated Carbon Steel Backing
S3	Seal	PTFE-Nitrile
S4	Piston Rod	Chrome-Plated Carbon Steel, AISI C1141
S5	O-Ring	Nitrile
S6	Tube	Glass Filament Wound
S7	Piston	Cast Iron, ASTM A126 CL B
S8	O-Ring	Nitrile
S9	Seal	PTFE
S10	Nut	Zinc Plated Carbon Steel
S11	Cylinder Cap	Ductile Iron, ASTM A536 65-45-12
S12	Tie Rod	Zinc Plated Carbon Steel or 316 Stainless Steel
S13	Washer	Zinc Plated Carbon Steel or 316 Stainless Steel
S14	O-Ring	Nitrile
S15	Nut	Zinc Plated Carbon Steel or 316 Stainless Steel
S16	Thread Seal	Steel and Nitrile
S17	Jam Nut	Zinc Plated Carbon Steel or 316 Stainless Steel
S18	Stop Screw	Zinc Plated Carbon Steel or 316 Stainless Steel
S19	Spring Assembly	Silicone Manganese Spring – AISI 5160; Ductile Iron Cap and Base – ASTM A536, Grade 80-55-06; Carbon Steel Rod and Washer – Grade 2
S21	Breather	Brass with Sintered Bronze Filter

Dimensions

Double-Acting & Spring Return-Single Cylinder

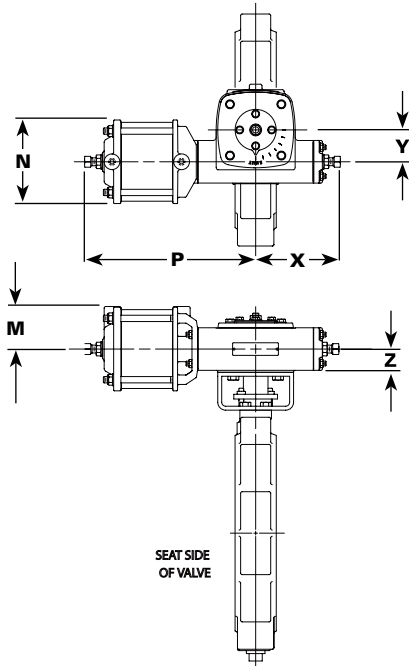

Double-Acting & Spring Return-Single Cylinder

Actuator	Dimensions					
	M	N	P	X	Y	Z
PR-R1A-PC4	2.31	4.50	12.12	5.75	1.47	1.50
	59	114	308	146	37	38
PR-R1A-PC6	3.38	6.62	12.62	5.75	1.47	1.50
	86	168	321	146	37	38
PR-R1-SC4A	3.88	4.50	15.38	5.75	1.47	1.50
	99	114	391	146	37	38
PR-R1-SC6A	4.94	6.62	16.38	5.75	1.47	1.50
	125	168	416	146	37	38
PR-R1-SC6B	4.94	6.62	17.69	5.75	1.47	1.50
	125	168	449	146	37	38
PR-R2A-PC6	3.38	6.62	16.00	7.50	2.53	1.84
	86	168	406	191	64	171
PR-R2A-PC8	3.38	10.25	16.12	7.50	2.53	1.84
	86	260	409	191	64	47
PR-R3A-PC8	4.81	10.25	19.25	9.69	3.84	2.31
	122	260	489	246	98	59
PR-R3A-PC10	5.88	11.75	19.25	9.69	3.84	2.31
	149	298	489	246	98	59

Spring Return-Double Cylinder

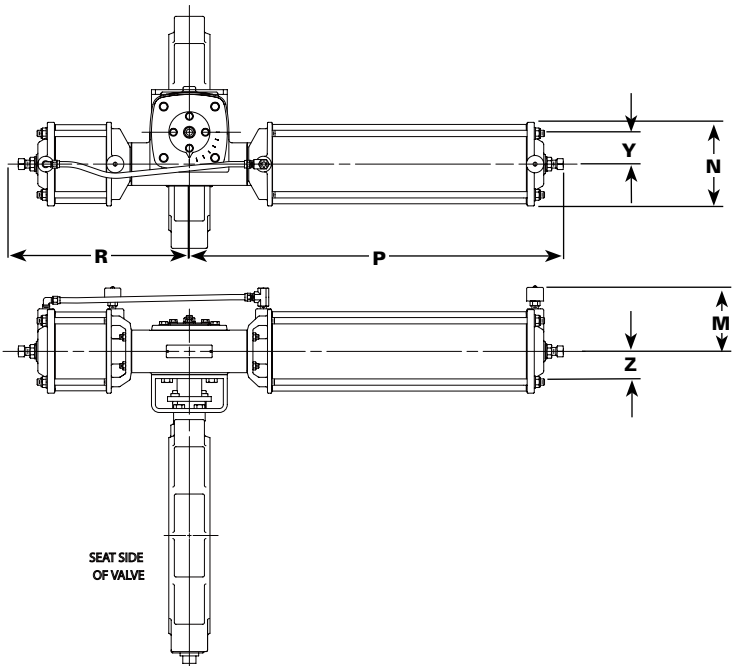

Spring Return-Double Cylinder

Actuator	Dimensions						
	M	N	P	R		Y	Z
				Spring-to-Close	Spring-to-Open		
PR-R1A-SC4	3.88	4.50	12.12	21	19.12	1.47	1.50
	99	114	308	533	486	37	38
PR-R1A-SC6	4.94	6.62	12.62	21.88	19.16	1.47	11.5
	126	168	321	556	487	37	38
PR-R2A-SC6	4.94	6.62	16.00	30.5	25.00	2.53	1.84
	126	168	406	775	635	64	47
PR-R2A-SC8	6.38	10.25	16.12	32.75	27.50	2.53	1.84
	162	260	409	832	698	64	47

Inches
Millimeter

Note: All dimensions are subject to change without notice. Request certified drawings for use in preparing piping layouts.

Actuator Mounting Positions

Double-Acting & Spring Return-Spring-to-Open Single Cylinder

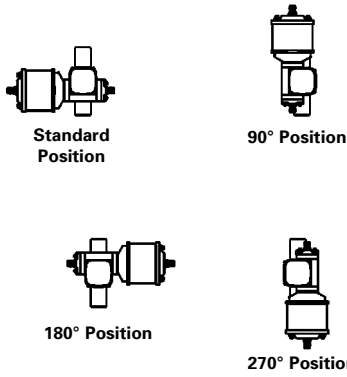

Spring Return Spring-to-Close-Single Cylinder

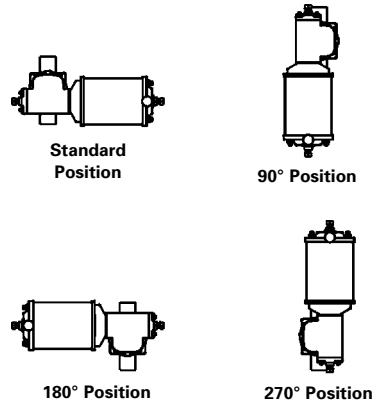

Spring Return Spring-to-Open-Double Cylinder

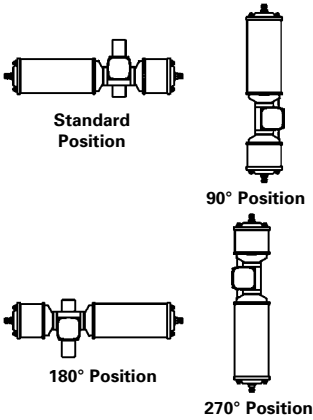

Spring Return Spring-to-Close-Double Cylinder

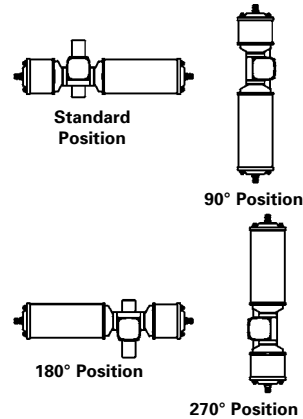

Actuator Torques & Weights

Double-Acting

Actuator Size	Torque-Ft-Lbs. (NM)		Weight LBS (KG)
	60 psi (4 Bar)	80 psi (5.5 Bar)	
PR-R1A-PC4	56 (76)	75 (102)	28 (13)
PR-R1A-PC6	126 (171)	170 (230)	42 (19)
PR-R2A-PC6	255 (346)	340 (461)	59 (27)
PR-R2A-PC8	450 (610)	600 (813)	82 (37)

Spring Return

Actuator Size	Torque Ft-Lbs. (NM) 60 psi (4 Bar)	Weight LBS (KG)	
		Spring-to-Open	Spring-to-Close
PR-R1A-SC4	56 (76)	50 (23)	53 (24)
PR-R1A-SC6	126 (171)	92 (42)	94 (43)
PR-R2A-SC6	255 (346)	114 (52)	129 (59)
PR-R2A-SC8	450 (610)	184 (83)	208 (94)
*PR-R1A-SC4A	56 (76)	36 (17)	38 (17)
*PR-R1A-SC6A	126 (171)	52 (24)	54 (25)
*PR-R1A-SC6B	126 (171)	56 (26)	58 (27)

*Single cylinder

Ordering

To order a PowerRac[®] actuator, select the actuator model from the appropriate valve style sizing charts. Specify mounting position on the line following the valve/actuator code. As reference information, the actuator code is defined in the following charts.

Double-Acting

Cylinder Type

Give cylinder type code as follows:

PR = PowerRac[®] Actuator
PRL = PowerRac[®] Actuator with Lockout

Gear Size

Give gear size code as follows:

R1A = 1" (25mm) Radius Gear
R2A = 2" (50mm) Radius Gear
R3A = 3" (80mm) Radius Gear

Cylinder Size

Give cylinder size code as follows:

PC4 = 4" (100mm) Diameter Cylinder
PC6 = 6" (150mm) Diameter Cylinder
PC8 = 8" (200mm) Diameter Cylinder
PC10 = 10" (250mm) Diameter Cylinder

Ordering Example:

BHP,2,L1,CS,TC,S2-S2-FT-TT*PR-R1A-PC4
180° actuator mounting

Spring Return

Cylinder Type

Give cylinder type code as follows:

PR = PowerRac[®] Actuator

Gear Size

Give gear size code as follows:

R1A = 1" (25mm) Radius Gear
R2A = 2" (50mm) Radius Gear

Cylinder Size

Give cylinder size code as follows:

Double Cylinder

SC4 = 4" (100mm) Diameter Cylinder
SC6 = 6" (150mm) Diameter Cylinder
SC8 = 8" (200mm) Diameter Cylinder

Single Cylinder

SC4A = 4" (100mm) Diameter Cylinder
SC6A = 6" (150mm) Diameter Cylinder
SC8A = 8" (200mm) Diameter Cylinder

Spring Action*

Give spring action code as follows:

D = Direct, Spring-to-Open
R = Reverse, Spring-to-Open

Spring Size*

Give spring size code as follows:

60 = 60 psi Minimum Rating

Ordering Example:

BHP,3,L1,S2,G1,S2NH-S5-NS-S2*PR-R1A-SC4-R-60
270° actuator mounting

* Note: Spring cylinders are not field reversible

Sales and Service

For information about our worldwide locations, approvals, certifications and local representative:

Web Site: www.dezurik.com E-Mail: info@dezurik.com



250 Riverside Ave. N. Sartell, Minnesota 56377 • Phone: 320-259-2000 • Fax: 320-259-2227

DeZURIK reserves the right to incorporate our latest design and material changes without notice or obligation. Design features, materials of construction and dimensional data, as described in this bulletin, are provided for your information only and should not be relied upon unless confirmed in writing by DeZURIK. Certified drawings are available upon request.