

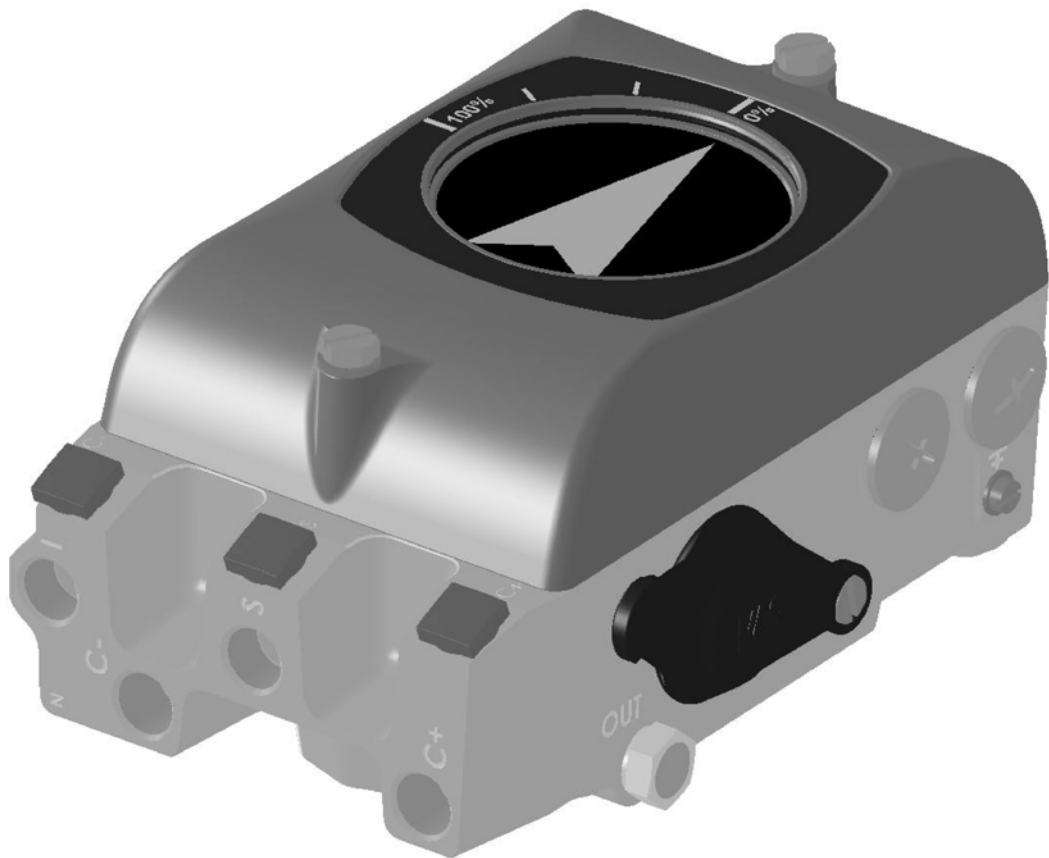

DeZURIK INSTRUCTIONS FOR FIELD
INSTALLATION OF VAC P200-P204
SERIES POSITIONER
ON G-SERIES ACTUATOR



Instructions

These instructions cover the steps necessary to install a VAC Positioner on a G-Series actuator. As the G-Series actuator is used on several DeZURIK products, follow the section of these instructions that matches your valve type. See Instruction D10471 for VAC positioner adjustments.

Safety Messages

All safety messages in the instructions are flagged with an exclamation symbol and the word Caution, Warning or Danger. These messages indicate procedures that must be followed exactly to avoid equipment damage, personal injury or death. Safety label(s) on the product indicate hazards that can cause equipment damage, personal injury or death.

Safety label(s) on the product indicate hazards that can cause equipment damage, personal injury or death. If a safety label becomes difficult to see or read, or if a label has been removed, please contact DeZURIK for replacement label(s).



WARNING!

Personnel involved in the installation or maintenance of valves should be constantly alert to potential emission of pipeline material and take appropriate safety precautions. Always wear suitable protection when dealing with hazardous pipeline materials. Handle valves, which have been removed from service with suitable protection for any potential pipeline material in the valve.

Inspection

Your VAC Positioner has been packaged to provide protection during shipment, however, it can be damaged in transport. Carefully inspect the unit for damage upon arrival and file a claim with the carrier if damage is apparent.

Parts

Recommended spare parts are listed on the assembly drawing. These parts should be stocked to minimize downtime.

Order parts from your DeZURIK sales representative, or directly from DeZURIK. When ordering parts, please include the 7-digit part number and 4-digit revision number (example: **9999999R000**) located on the data plate attached to the valve assembly. Also include the part name, the assembly drawing number, the balloon number and the quantity stated on the assembly drawing.

DeZURIK Service

DeZURIK service personnel are available to install, maintain and repair all DeZURIK products. DeZURIK also offers customized training programs and consultation services.

For more information, contact your local DeZURIK sales representative or visit our website at www.dezurik.com.

Table of Contents

Installation on PEC Eccentric Plug Valves - - - - -	4
Installation on PTW/PFW 3 & 4 Way Plug Valves - - - - -	7

DeZURIK

Field Installation of VAC P200-P204 Series Positioner on G-Series Actuator

Installation on PEC Eccentric Plug Valves

Carefully follow these steps to properly install the VAC Positioner on PEC Eccentric Plug valves with the G-Series actuator. It is necessary to Loctite the stud supplied with this kit into the top of the valve plug stem to prevent the stud from loosening when it drives the positioner. See the drawing sent with this kit for component identification.



CAUTION!

Before beginning installation of the positioner, discontinue pipeline flow and relieve pipeline pressure. Failure to relieve pipeline pressure may result in personal injury and/or flow system damage.

1. Discontinue pipeline flow.
-



CAUTION!

Moving parts from accidental operation of power actuator can cause personal injury or equipment damage. Disconnect and lock out power to actuator before servicing.

2. Disconnect and lock out the power supply to the actuator to prevent accidental operation of the actuator.
3. Remove the lock nut, spring washers, wrenching nut and pointer from the top of the actuator.
4. Unscrew the old stud that now extends from the top of the actuator. If the valve already has a switch or positioner mounted on it, the old stud may have been pinned to the plug stem. It is necessary to remove the actuator to reach the pin.
5. Remove the actuator as described in Instruction D10022.
6. Remove the pin and stud, then reinstall actuator as described in the ACTUATOR INSTALLATION section of Instruction D10022.
7. Clean the shorter threads of the stud supplied with the kit.
8. Apply removable Loctite 242 Thread Locking Compound to the shorter threads, then install and tighten the stud into the plug stem.
9. After the Loctite has set, slide the Stud Support over the stud and into the hex flats of the gear.
10. Place the spring washers on the Stud Support as shown in Figure 1.
11. Supplied with the kit are two hex lock nuts. Screw the thicker of the two nuts down the plug stud until the spring washers are completely compressed and the nut is tight, then back off the nut one turn.

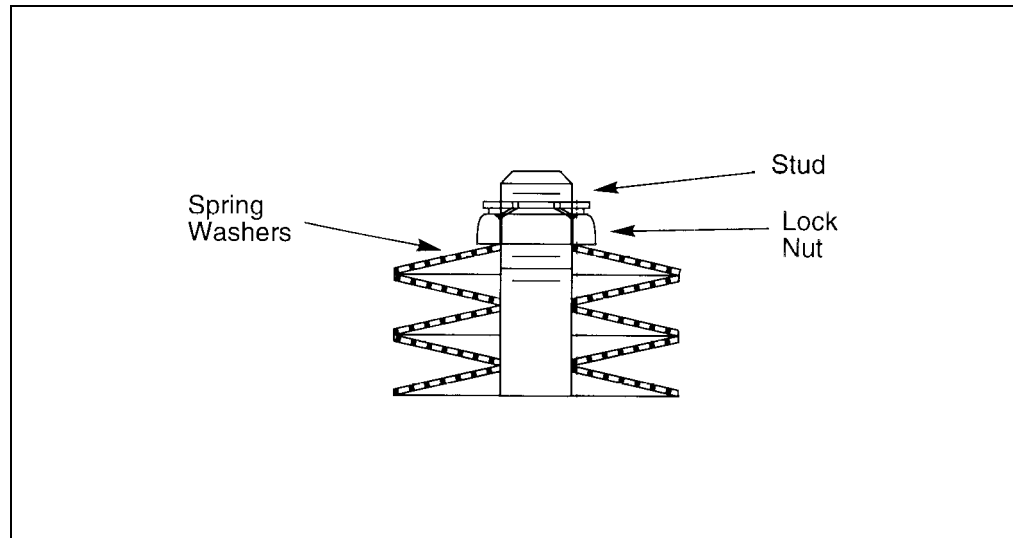
Installation on PEC Eccentric Plug Valves *(Continued)***Figure 1 — Spring Washer Arrangement**

12. Screw the thinner hex nut onto the stud until it touches the thicker nut.
13. Install the toothed lockwasher.
14. Place coupling block onto stud and tighten to 26 foot pounds minimum torque.
15. See the Assembly Drawing supplied with this kit for positioner and bracket orientation on the actuator, then mount the positioner to the bracket with the four metric screws and lockwashers provided.
16. Set the positioner and bracket assembly onto the valve, sliding the flats of the positioner shaft into the coupling block.

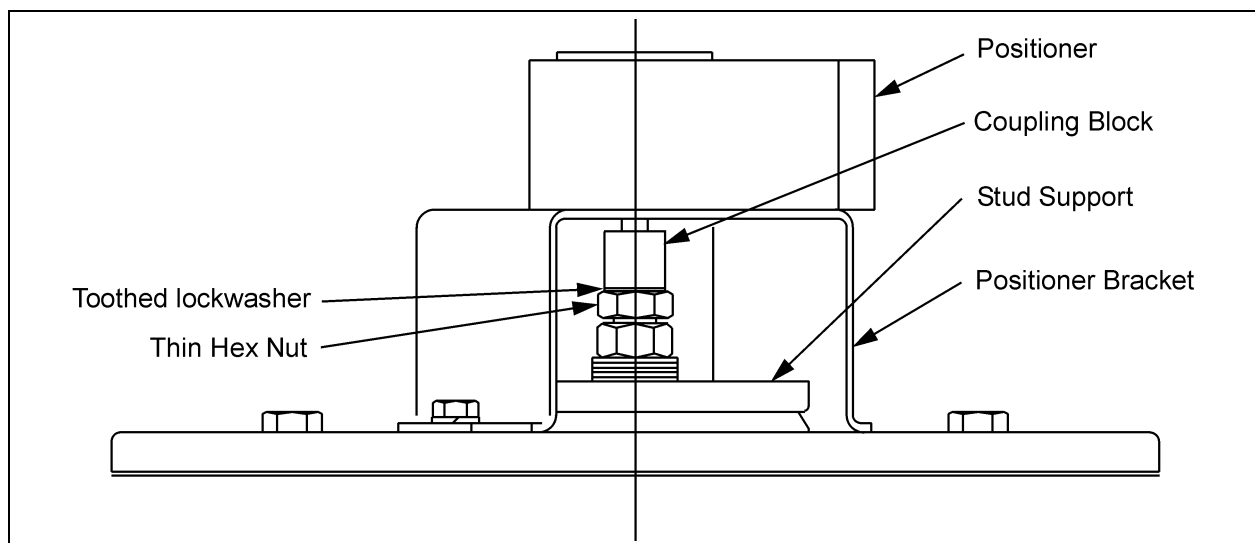
**Figure 2 — Coupling Block Location on Eccentric Valve**

DeZURIK

Field Installation of VAC P200-P204 Series Positioner on G-Series Actuator

Installation on PEC Eccentric Plug Valves *(Continued)*

17. If you are mounting the bracket to a G4 or G6 actuator (cover diameters of 7-1/8 inches or 8-1/8 inches, respectively), mount the bracket using two of the actuator cover screws as shown in the Assembly Drawing.
18. On G12 & G16 actuators (cover diameters of 15 inches and 19 inches, respectively), it is necessary to grind off some of the raised indicator marks on the actuator cover so the bracket can sit flat on the cover. It is also necessary to drill and tap two holes in the top of the cover for mounting the bracket. With all of the parts assembled thus far to aid in alignment, follow these steps:
 - a. Align the positioner and bracket assembly on the cover as shown on the Assembly Drawing.
 - b. Mark the required mounting hole locations using the bracket holes as a guide, then remove the positioner and bracket assembly from the coupling block.
 - c. Scribe a line on the side of the actuator cover and housing for alignment during reassembly, then remove the cover from the actuator.
 - d. Drill and tap two 3/8-16 N.C. holes through the cover on the marks made with the bracket.
 - e. Grind off some of the raised indicator marks on the cover where the bracket will sit.
 - f. Line up the scribe marks and install the cover on the actuator.
 - g. Mount the positioner and bracket to the cover using two screws and lockwashers.
19. Port connections vary depending on the action required by the valve and positioner. Connect the cylinder ports to positioner ports "C+" and "C-" for double acting cylinders, and to either "C+" or "C-" for spring return cylinders. On spring return cylinders, the unused "C" port in the positioner is plugged with a pipe plug.
20. Connect the instrument and supply air to the positioner and adjust the cam, span, zero, indicator and make any other adjustments as described in Instruction D10471.
21. When positioner adjustments are complete and the valve is operating properly, pipeline flow can be restored.

Installation on PTW/PFW 3 & 4 Way Plug Valves

Carefully follow these steps to install the VAC Positioner on PTW/PFW 3 & 4 Way Tapered Plug valves with the G-Series actuator. It is necessary to Loctite the stud supplied with this kit into the top of the valve plug stem to prevent the stud from loosening when it drives the positioner. See Assembly Drawing included in this kit for component identification.

**CAUTION!**

Before beginning installation of the positioner, discontinue pipeline flow and relieve pipeline pressure. Failure to relieve pipeline pressure may result in personal injury and/or flow system damage.

1. Discontinue pipeline flow.
-

**CAUTION!**

Moving parts from accidental operation of power actuator can cause personal injury or equipment damage. Disconnect and lock out power to actuator before servicing.

2. Disconnect and lockout the power supply to the actuator to prevent accidental operation of the actuator.
3. If the valve now has a positioner on it, remove the old positioner, bracket and positioner drive nut or linkage from the valve.
4. Unscrew the hex nut from the top of the wrenching square.
5. Remove the four socket head screws, and remove the wrenching square.
6. Note the position of the pointer, then remove the two socket head screws and slide the pointer off the actuator.
7. The plug adjusting nut holds the plug up to provide clearance between the plug face and the body seat. If the valve can be removed from the pipeline, measure the clearance with a feeler gage. If you have not removed or cannot remove the valve from the pipeline so you can measure the plug/seat clearance with a feeler gage, you must determine plug clearance by counting the number of turns to loosen the plug adjusting nut. Note the location of the wrench flats on the brass nut, then carefully turn the nut counterclockwise, counting the number of turns it takes until the flange of the nut just starts to clear the bearing washer. Record this number for use during reassembly.
8. Remove the plug adjusting nut from the stud, and slide the bearing washer off the valve.
9. Unscrew the old stud that now extends from the top of the actuator. If the valve already had a switch or positioner mounted on it, the old stud may have been pinned to the plug stem. It is necessary to remove the actuator to gain access to the pin.
10. Remove the actuator as described in Instruction D10191.

Installation on PTW/PFW 3 & 4 Way Plug Valves *(Continued)*

11. Remove the pin and stud, then reinstall actuator as described in the ACTUATOR INSTALLATION section of Instruction D10047.
12. Clean the shorter threads of the stud supplied with the kit.
13. Apply removable Loctite 242 Thread Locking Compound to the shorter threads, install and tighten the stud into the plug stem.
14. After the Loctite has set, install the bearing washer on top of the gear.
15. Screw the plug adjusting nut onto the stud until it touches the bearing washer.
16. Turn the plug adjusting nut clockwise the number of turns noted during disassembly, or until you get the clearance measured with the feeler gage in Step 7.
17. Set the pointer on the bearing washer so it fits down over the plug adjusting nut, then turn it until it is positioned as noted during disassembly. Fasten the pointer to the gear sector with the two shorter socket head screws.
18. Set the wrenching square on the pointer and fasten it to the gear sector with the four remaining socket head screws.
19. Screw the nut on the stud until it touches the wrenching square. Tighten the nut to lock the assembly in place.
20. See Figure 3. Screw the thin hex nut from the kit onto the stud until it touches the thicker nut.
21. Install the toothed lockwasher, then place coupling block onto stud and tighten to 26 foot pounds minimum torque.
22. Set the positioner and bracket assembly onto the valve, sliding the flats of the positioner shaft into the coupling block.

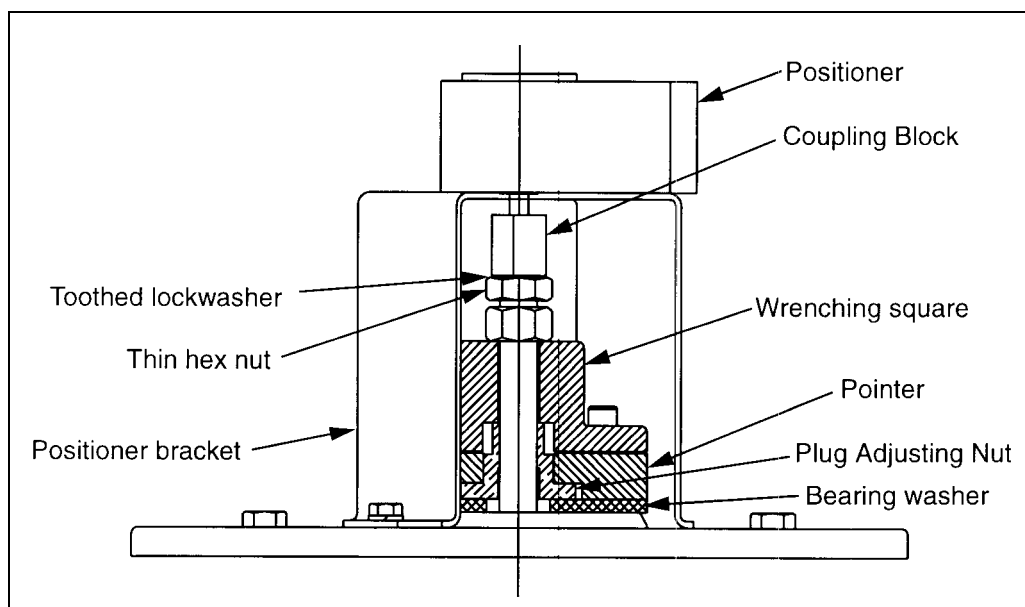
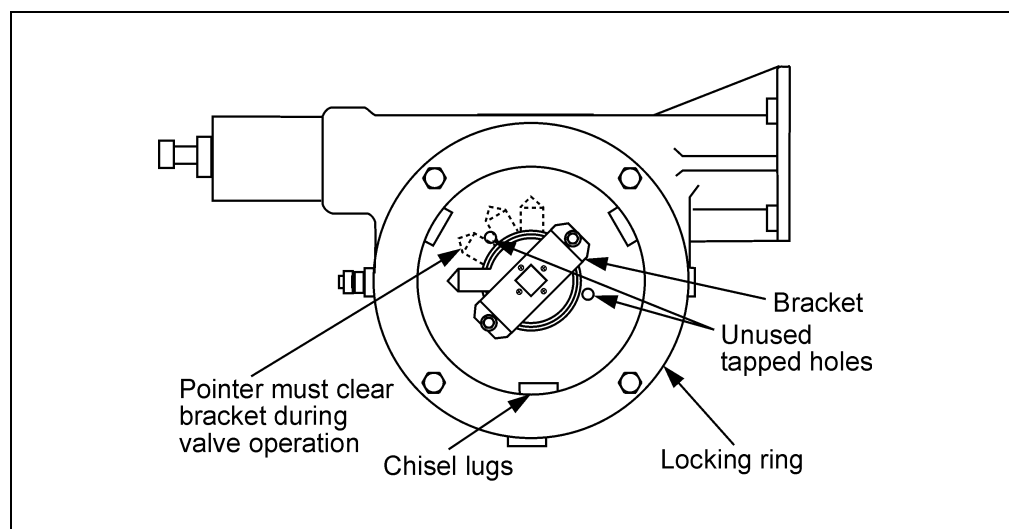

Figure 3 — Coupling Block Location on 3 & 4 Way Plug Valves

Installation on PTW/PFW 3 & 4 Way Plug Valves *(Continued)*

23. See the Assembly Drawing supplied with this kit for positioner and bracket orientation on the actuator, then mount the positioner to the bracket with the four metric screws and lockwashers provided.
24. If you are mounting the bracket to a G4 or G6 actuator (cover diameters of 7-1/8 inches or 8-1/8 inches, respectively), mount the bracket using two of the actuator cover screws as shown in the Assembly Drawing.
25. On G12 actuators (cover diameter of 15 inches), there are four 5/8-11 tapped holes that are plugged with socket head setscrews. Two of these setscrews will be used to mount the bracket as follows:
 - a. Find the two setscrews that are located directly across from each other and remove them. These setscrews were installed with Loctite and may be difficult to remove.
 - b. See Figure 4. Check the orientation of the bracket so it does not interfere with the pointer during valve operation. If the bracket will be hit by the pointer during valve operation, loosen the four hex head screws on the outer cover ring. Then using a hammer and chisel, rap on one of the three raised rectangular bosses to turn the cover to a position such that the pointer will not hit the bracket. When the cover is positioned properly, tighten the four hex head screws to lock the cover in place.
 - c. Mount the bracket to the cover using two socket head screws.
26. Port connections vary depending on the action required by the valve and positioner. Connect the cylinder ports to positioner ports "C+" and "C-" for double acting cylinders, and either "C+" or "C-" for spring return cylinders. On spring return cylinders, the unused "C" port in the positioner is plugged with a pipe plug.
27. Connect the instrument and supply air to the positioner and adjust the cam, span, zero, indicator and any other adjustments as described in Instruction D10471.
28. When positioner adjustments are complete and the valve is operating properly, pipeline flow can be restored.

**Figure 4 — Bracket Oriented to Clear Pointer During Valve Operation**