



# DeZURIK TEN-POSITION LEVER MANUAL ACTUATOR

Instruction D10316  
June 2011

# DeZURIK

## Ten-Position Lever Manual Actuator

---

### Instructions

These instructions provide information about Lever Actuators. They are for use by personnel who are responsible for installation, operation and maintenance of Lever Actuators.

### Safety Messages

All safety messages in the instructions are flagged with an exclamation symbol and the word Caution, Warning or Danger. These messages indicate procedures that must be followed exactly to avoid equipment damage, personal injury or death.

Safety label(s) on the product indicate hazards that can cause equipment damage, personal injury or death. If a safety label becomes difficult to see or read, or if a label has been removed, please contact DeZURIK for replacement label(s).



#### **WARNING!**

**Personnel involved in the installation or maintenance of valves should be constantly alert to potential emission of pipeline material and take appropriate safety precautions. Always wear suitable protection when dealing with hazardous pipeline materials. Handle valves, which have been removed from service with suitable protection for any potential pipeline material in the valve.**

---

### Inspection

Your Lever Actuator has been packaged to provide protection during shipment, however, it can be damaged in transport. Carefully inspect the unit for damage upon arrival and file a claim with the carrier if damage is apparent.

### Parts

Recommended spare parts are listed on the assembly drawing. These parts should be stocked to minimize downtime.

Order parts from your DeZURIK sales representative, or directly from DeZURIK. When ordering parts, please include the 7-digit part number and 4-digit revision number (example: **9999999R000**) located on the data plate attached to the valve assembly. Also include the part name, the assembly drawing number, the balloon number and the quantity stated on the assembly drawing.

### DeZURIK Service

DeZURIK service personnel are available to install, maintain and repair all DeZURIK products. DeZURIK also offers customized training programs and consultation services.

For more information, contact your local DeZURIK sales representative or visit our website at [www.dezurik.com](http://www.dezurik.com).

## Table of Contents

Description - - - - -	4
Operation - - - - -	4
Closed Position Adjustment - - - - -	4
Locking the Actuator	
<i>Padlocking for the small size lever</i> - - - - -	4
<i>Padlock for the medium and large size levers</i> - - - - -	5
Open Position (Optional) - - - - -	5
Removing Actuator - - - - -	5
Installing Actuator - - - - -	7
Changing Mounting Position - - - - -	7

### Description

The Ten-Position Lever is a manual actuator for 90° rotation of Butterfly Valves. The actuator holds the valve in the open or closed position, or in any of eight other equally-spaced intermediate positions. A lockout feature allows the actuator to be padlocked in any of the ten positions. There are three sizes of levers as shown in Figure 1.

An Adjustable Open Position Stop is available as an option. This device prevents the actuator from opening beyond a preset partially-open position.

### Operation

To operate the actuator, firmly grasp and squeeze the end of the handle and the lever to disengage the lever; then slowly rotate the handle to the desired valve position. Clockwise rotation closes the valve, and counterclockwise rotation opens the valve. Ensure that the lever is engaged in one of the 10 notches before releasing the handle.



#### **CAUTION!**

1. Close the valve slowly. Rapid closure of the valve can cause pipeline pressure surges that will damage pipeline equipment.
  2. Ensure that the lever is engaged in one of the 10 notches before releasing the handle. If the lever is not engaged, the valve can slam closed and cause pipeline pressure surges that will damage pipeline equipment.
- 

### Closed Position Adjustment

If the valve is not closed when the actuator is in the closed position, the closed position of the actuator may be adjusted as described below. Maintain a firm grip on the actuator during adjustment to prevent pipeline damage as described in the OPERATION section above. Refer to Figure 1 for component identification.

1. Loosen the two dial screws and place the valve—not the actuator—in the closed position.
2. Rotate the dial so that the handle points to “shut” and the lever engages with the last (most clockwise) notch in the dial.
3. Tighten the two dial screws to the torque shown in Table A.
4. Operate the actuator to the open and closed positions to confirm that the valve is closed when the actuator is in the closed position. Repeat steps 1 through 4 if necessary.

### Locking the Actuator

A lockout feature allows the actuator to be padlocked in any of the 10 actuator positions. To lock the actuator, insert the padlock (not included) between the lever and the handle as shown in Figure 1. See recommendations below.

#### ***Padlock for the small size lever:***

Master No. 510 or equivalent, with a 9/32" (7.1 mm) diameter removable shackle, 2" (50 mm) vertical clearance, and 13/16" (21 mm) horizontal clearance, as shown in Figure 1.

**Locking the Actuator** *(Continued)***Padlock for the medium and large size levers:**

Master No. 5 or equivalent, with a 3/8" (9.5 mm) diameter shackle, 2½" (64 mm) vertical clearance, and 15/16" (24 mm) horizontal clearance, as shown in Figure 1.

**Open Position Stop** (Optional)

The optional Adjustable Open Position Stop prevents the actuator from opening beyond a preset partially-open position. To adjust the stop:

1. Loosen the screw that mounts the stop to the dial.
2. Place the actuator in the desired partially-open position, with the lever engaged in one of the ten dial notches.
3. Rotate the stop so that the stop is against the handle.
4. Tighten the stop mounting screw to the torque shown in Table A.

**Table A: Fastener Torques**

Fastener Size	Carbon Steel		Stainless Steel	
	(ft lbs)	(Nm)	(ft lbs)	(Nm)
1/4-20	7 ± 1	9 ± 1	45 ± 6 (in lbs)	5.1 ± 0.7
5/16-18	14 ± 2	19 ± 3	8 ± 1	11 ± 1
3/8-16	26 ± 3	35 ± 4	15 ± 2	20 ± 3
1/2-13	63 ± 8	85 ± 11	38 ± 5	52 ± 7
M8 X 1.25	23 ± 3	31 ± 4	16 ± 2	22 ± 3
M10 X 1.5	47 ± 6	64 ± 8	33 ± 4	45 ± 5
M12 X 1.75	83 ± 10	113 ± 14	58 ± 8	79 ± 1

**Removing Actuator****WARNING!**

Flow in the pipeline with the actuator removed can allow the valve to slam closed and cause personal injury and/or damage to the flow system. Shut down the flow in the pipeline before removing the actuator.

Refer to Figure 1 for actuator component identification.

1. Shut down the flow in the pipeline.
2. Close the valve.
3. Loosen the screw that secures the handle to the valve shaft.
4. While squeezing the lever, lift and remove the handle from the valve shaft.
5. Remove the two dial screws and the dial.

# DeZURIK

## Ten-Position Lever Manual Actuator

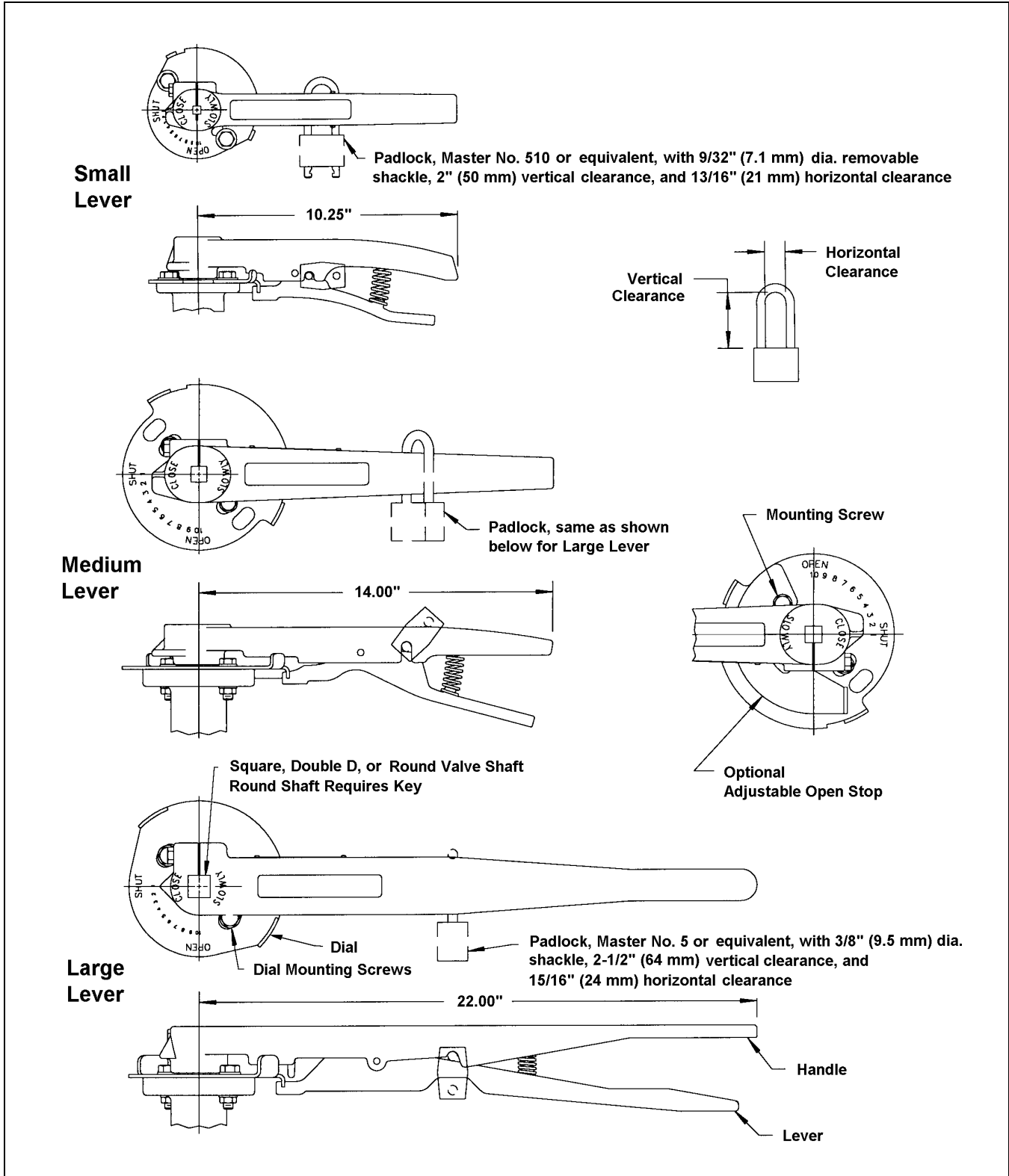

**Figure 1 – Actuator Components**

## Installing Actuator

Refer to Figure 1 for actuator component identification.

1. Select the desired actuator mounting position. The actuator may be mounted in any of two or four positions, as shown on the Installation Drawing for the Valve; however, the standard position shown is recommended—with the handle perpendicular to the pipeline when the valve and actuator are in the closed position.
2. Mount the dial to the top of the valve with the two screws. Tighten the screws finger tight.
3. If the valve has a round keyed shaft, lubricate the key with light grease, and place the key in the valve shaft.
4. Place the handle in position on the valve shaft, and against the dial.
5. Tighten the screw in the handle to the torque in Table A.
6. Adjust the closed position as described in the Closed Position Adjustment section.

## Changing Mounting Position

The actuator may be mounted on the valve in any of two or four mounting positions, as shown on the Installation Drawing for the valve. To change to a different mounting position:

1. Remove the actuator as described in the *Removing Actuator* section.
2. Determine the new mounting position for the actuator, and replace the actuator on the valve as described in the *Installing Actuator* section.