



VPB V-PORT BALL VALVES TECHNICAL SPECIFICATIONS

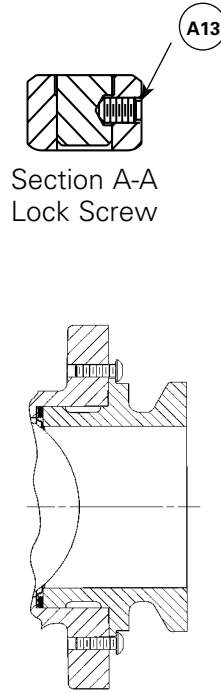
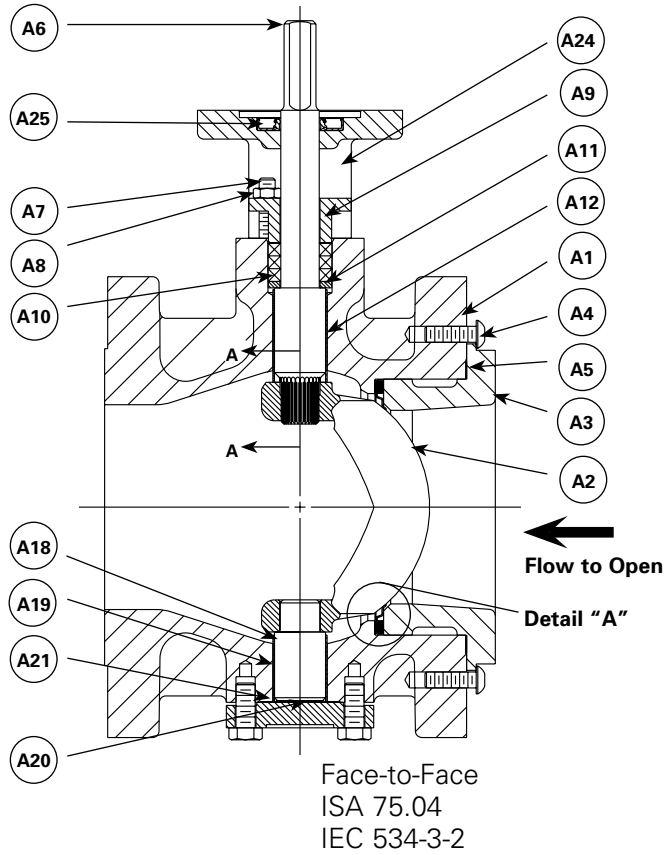

Table of Contents

Materials of Construction	3
Valve Selection	6
Valve Weights.....	6
Ordering.....	7
Lever Actuators	8
Manual Actuators	8
Cylinder Actuators	8
Diaphragm Actuators.....	8
Dimensions.....	9
Basic Valve	9
Lever.....	9
Tie Bolt & Bolt Lengths-Flangeless	10
Bolt Lengths-Flanged	11

Materials of Construction

Flanged Construction
 1-20" (25-500mm) Class 150
 1-12" (25-300mm) Class 300



Detailed "D"
 (Enlarged)

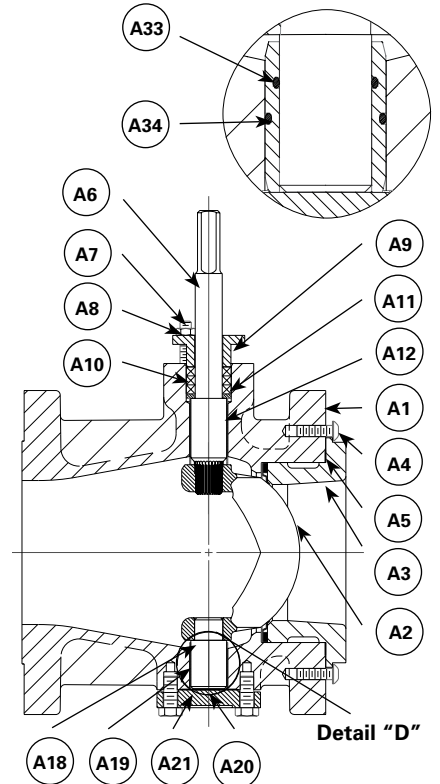

Flangeless Construction
 1-12" (25-300mm) Class 150

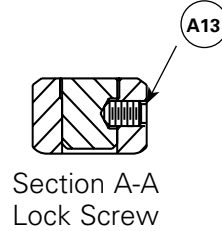
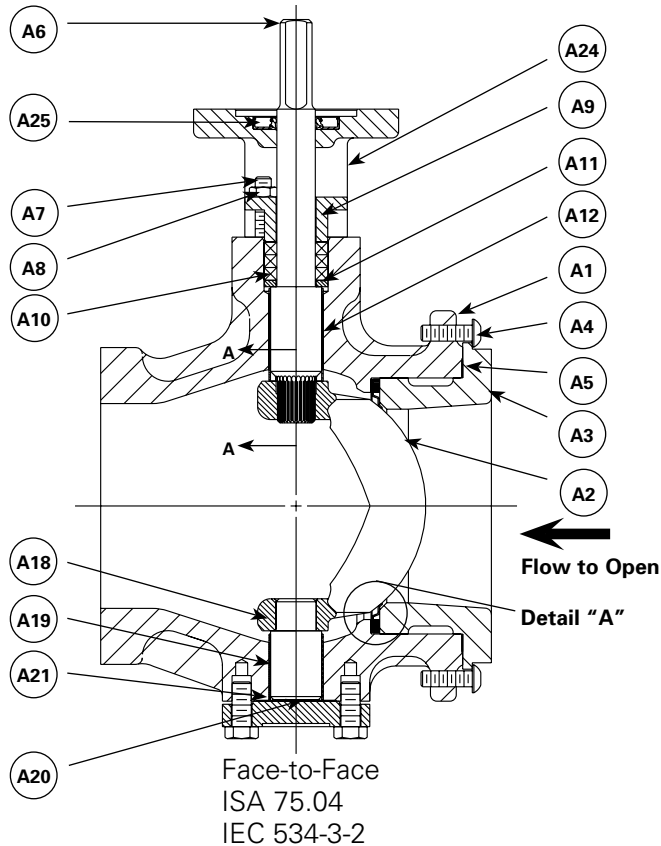

ISO 5752 - Series 3
 EN 558-1 - Series 3

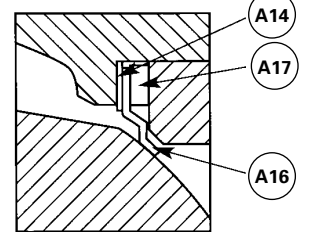

Flexible Metal Seat

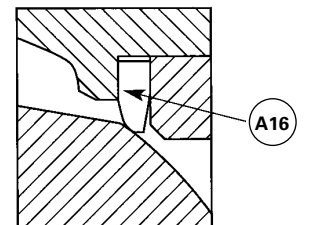

Reinforced PTFE Seat

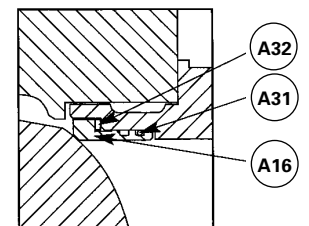

Rigid Metal Seat

Materials of Construction

316 and 317 Stainless Steel Bodies

Description	316 Stainless Steel Body (Class 300 only)	317 Stainless Steel Body
A1 Body	316 stainless steel, ASTM A351, Grade CF8M	317 stainless steel, ASTM A351, Grade CG8M
A2 Ball	317 stainless steel heat treated nickel overlay, ASTM A351, Grade CG8M	317 stainless steel heat treated nickel overlay, ASTM A351, Grade CG8M
	317 stainless steel with tungsten carbide overlay, ASTM A351, Grade CG8M	317 stainless steel with tungsten carbide overlay, A351, Grade CG8M
A3 Retainer	317 stainless steel, ASTM A351, Grade CG8M	317 stainless steel, ASTM A351, Grade CG8M
A4 Retainer Screw	18-8 stainless steel	18-8 stainless steel
A5 Retainer Gasket	Graphite	Graphite
A6 Upper Shaft	2205 Duplex stainless steel, ASTM A276	2205 Duplex stainless steel, ASTM A276
	17-4 PH stainless steel, ASTM A564, H900	17-4 PH stainless steel, ASTM A564, H900
A7/A8 Packing Stud/Nut	18-8 stainless steel	18-8 stainless steel
A9 Packing Gland	317 stainless steel, ASTM A351, Grade CG8M	317 stainless steel, ASTM A351, Grade CG8M
A10 Packing	PTFE or carbon graphite	PTFE or carbon graphite
A11 Packing Washer	317 stainless steel, ASTM A276	317 stainless steel, ASTM A276
A12 Upper Bearing	Reinforced PTFE Fabric	Reinforced PTFE Fabric
	440C stainless steel, ASTM A276	440C stainless steel, ASTM A276
	440C stainless steel, ASTM A276	Alloy 6, AMS 5387B, Stellite®
A13 Lock Screw	Alloy 20, B473	Alloy 20, B473
A14 Gasket (Metal Seated Only)	Graphite	Graphite
A16 Seat	Reinforced PTFE	Reinforced PTFE
	Flexible 317 stainless steel with heat treated electroless nickel overlay, ASTM A240	Flexible 317 stainless steel with heat treated electroless nickel overlay, ASTM A240
	Rigid 317 stainless steel with tungsten carbide overlay, ASTM A351, Grade CG8M or ASTM A240/A276	Rigid 317 stainless steel with tungsten carbide overlay, ASTM A351, Grade CG8M or ASTM A240/A276
	Rigid 317 stainless steel with heat treated nickel overlay, ASTM A351, Grade CG8M or ASTM A240/A276	Rigid 317 stainless steel with heat treated nickel overlay, ASTM A351, Grade CG8M or ASTM A240/A276
A17 Gasket (Metal Seated Only)	Graphite	Graphite
A18 Lower Shaft	2205 Duplex stainless steel, ASTM A276	2205 Duplex stainless steel, ASTM A276
	17-4 PH stainless steel, ASTM A564, H900	17-4 PH stainless steel, ASTM A564, H900
A19 Lower Bearing	Reinforced PTFE fabric	Reinforced PTFE fabric
	440C stainless steel, ASTM A276	440C stainless steel, ASTM A276
	Alloy 6, AMS 5387B, Stellite®	Alloy 6, AMS 5387B, Stellite®
A20 Thrust Bearing	Reinforced PTFE fabric	Reinforced PTFE fabric
A21 Gasket	Graphite	Graphite
A22 Cover	317 stainless steel, ASTM A351, Grade CG8M	317 stainless steel, ASTM A351, Grade CG8M
A23 Screws	18-8 stainless steel	18-8 stainless steel
A24 Adapter	Ductile iron, ASTM A536, Grade 65-45-12	Ductile iron, ASTM A536, Grade 65-45-12
A25 Adapter Seal	Nitrile	Nitrile
A27/A28 Adapter Screws/ Lock Washer (Not Shown)	316 stainless steel	316 stainless steel
A31 Seal (Rigid Seat Only)	Fluoroelastomer, PFA encapsulated	Fluoroelastomer, PFA encapsulated
A32 Spring (Rigid Seat Only)	17-7 PH stainless steel, ASTM A313	17-7 PH stainless steel, ASTM A313
	Inconel, ASTM B637 N07750	Inconel, ASTM B637 N07750
A33/34 Seal	Fluoroelastomer, PFA encapsulated	Fluoroelastomer, PFA encapsulated
	Kalrez®	Kalrez®

Materials of Construction

Hastelloy C & Carbon Steel Bodies

Description	Hastelloy C Body	Carbon Steel Body
A1 Body	Hastelloy C, ASTM A494, Grade CW2M	Carbon steel, ASTM A216, Grade WCB
A2 Ball	Hastelloy C with heat treated electroless nickel overlay ASTM A494 Grade CW2M	317 stainless steel with tungsten carbide overlay, A351, Grade CG8M 317 stainless steel with heat treated nickel overlay, A351, Grade CG8M
A3 Retainer	317 stainless steel, ASTM A351, Grade CG8M	317 stainless steel, ASTM A351, Grade CG8M
A4 Retainer Screw	18-8 stainless steel	18-8 stainless steel
A5 Retainer Gasket	Graphite	Graphite
A6 Upper Shaft	Hastelloy C, ASTM B574	17-4 PH stainless steel, ASTM A564, H900 2205 Duplex stainless steel, ASTM A276
A7/A8 Packing Stud/Nut	18-8 stainless steel	18-8 stainless steel
A9 Packing Gland	Hastelloy C, ASTM A494, Grade CW2M	317 stainless steel, ASTM A351, Grade CG8M
A10 Packing	PTFE or carbon graphite	PTFE or carbon graphite
A11 Packing Washer	Hastelloy C, ASTM B574/B575	317 stainless steel, ASTM A276
A12 Upper Bearing	Hastelloy C, ASTM B574/B575	Reinforced PTFE Fabric
		440C stainless steel, ASTM A276
		Alloy 6 AMS 5387B, Stellite®
A13 Lock Screw	Alloy 20, B473	Alloy 20, B473
A14 Gasket (Metal Seated Only)	Graphite	Graphite
A16 Seat	Rigid Hastelloy with heat treated electroless nickel overlay, ASTM A494, Grade CW2M or ASTM B574/B575	Reinforced PTFE
		Flexible 317 stainless steel with heat treated electroless nickel overlay, ASTM A240
		Rigid 317 stainless steel with tungsten carbide overlay, ASTM A351, Grade CG8M or ASTM A240/A276 Rigid 317 stainless steel with heat treated nickel overlay, ASTM A351, Grade CG8M or ASTM A240/A276
A17 Gasket (Metal Seated Only)	Graphite	Graphite
A18 Lower Shaft	Hastelloy C, ASTM B574	2205 Duplex stainless steel, ASTM A276
		17-4 stainless steel, ASTM A564, H900
A19 Lower Bearing	Hastelloy C, ASTM B574 or B575	Reinforced PTFE fabric
		440C stainless steel, ASTM A276
		Alloy 6, AMS 5387B, Stellite®
A20 Thrust Bearing (Only With PTFE Seat)	Reinforced PTFE fabric	Reinforced PTFE fabric
A21 Gasket	Graphite	Graphite
A22 Cover	Hastelloy C, ASTM A494, Grade CW2M	317 stainless steel, ASTM A351, Grade CG8M
A23 Screws	18-8 stainless steel	18-8 stainless steel
A24 Adapter	Ductile iron, ASTM A536, Grade 65-45-12	Ductile iron, ASTM A536, Grade 65-45-12
A25 Adapter Seal	Nitrile	Nitrile
A27/A28 Adapter Screws/ Lock Washer (Not Shown)	18-8 stainless steel	18-8 stainless steel
A31 Seal (Rigid Seat Only)	Fluoroelastomer, PFA encapsulated	Fluoroelastomer, PFA encapsulated
A32 Spring (Rigid Seat Only)	17-7 PH stainless steel, ASTM A313	17-7 PH stainless steel, ASTM A313
	Inconel, ASTM B637 N07750	Inconel, ASTM B637 N07750
A33/34 Seal	317 stainless steel with PTFE bonded fabric	317 stainless steel with PTFE bonded fabric
	Fluoroelastomer, PFA encapsulated	Fluoroelastomer, PFA encapsulated
	Kalrez®	Kalrez®

Valve Selection

Flow Characteristic

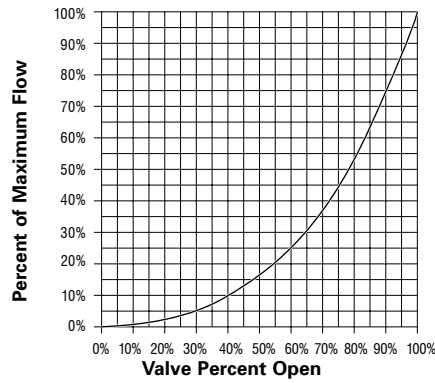

Shutoff

Seat	ANSI Class	Max. Shutoff Pressure Differential
		Flow to Open
Flexible Metal	IV	275 psi 1895 kPa
Reinforced PTFE	VI	275 psi 1895 kPa
Rigid Metal	IV	275 psi 1895 kPa

ANSI Body Rating/Face-to-Face

Class 150 Flanged 1-20" (25-500mm)	Flanged Class 150 ANSI B16.10 ISO 5752 PN 10/16 EN 558-1 PN 10/16 1-12" (25-300mm) only
	Flanged Class 150 ISA 75.04 or IEC 534-3-2: 1-20" (25-500mm)
	Flanged Class 150 Long Body B16.10, ISO 5752 and EN 558-1PN 10/16, 1-12" (25-300mm) except 2.5" (65mm)
Class 150 Flangeless 1-12" (25-300mm)	Flangeless Class 150 ISA 75.04 or IEC 534-3-2
Class 300 Flangeless 1-12" (25-300mm)	Flanged Class 300 ISA 75.04, IEC 534-3-2

Applicable Standards

ANSI/FCI 70-2	Control valve seat leakage
ANSI B16.5	Pipe flanges and flanged fittings for Class 150 and 300
ANSI B16.34	Pressure/temperature ratings for Class 150 and 300 valves
MSS-SP-25	Marking requirements
Bolting	ANSI 150 & 300, PN 10, 16, 25 & 40, JIS 10, 16 & 20
ISA S75.04	Face-to-Face dimensions
ANSI B16.10	Face-to-Face dimensions
IEC 534-3-2	Face-to-Face dimensions
ISO 5752 PN 10/16	Basic Series 3
	Face-to-Face dimensions
EN 558-1 PN 10/16	Basic Series 3
	Face-to-Face dimensions

Lever Actuator Weights

Infinite Position Lever	
Valve Size	lbs./kg.
1-3" 25-65mm	5 2.2
4" 100mm	9 4.1

Cv/Kv Values

Valve Size	100% Open	
	Seat Type	
	Flexible Metal & Rigid Metal	Reinforced PTFE
1" 25mm	36 31	40 35
1.5" 40mm	120 104	135 117
2" 50mm	210 182	235 203
2.5" 65mm	260 225	295 255
3" 80mm	360 311	420 363
4" 100mm	600 519	690 597
6" 150mm	1230 1060	1290 1120
8" 200mm	2015 1740	2190 1890
10" 250mm	3250 2810	3440 2980
12" 300mm	4225 3660	4390 3800
14" 350mm	5830 5040	6060 5240
16" 400mm	6490 5610	6715 5810
18" 450mm	9150 7920	9470 8190
20" 500mm	10915 9440	11300 9780

Valve Weights

Valve Size	Class 150 Flanged lbs./kg.	Class 150 Flangeless lbs./kg.	Class 300 Flanged lbs./kg.	Add for ANSI (Long Body) Face-to-Face lbs./kg.
1" 25mm	12 5	9 4	15 7	0.5 0.2
1.5" 40mm	17 8	12 5	24 11	2.0 0.9
2" 50mm	21 10	13 6	27 12	2.8 1.3
2.5" 65mm	32 15	20 9	40 18	-
3" 80mm	47 21	35 16	58 26	3.3 1.5
4" 100mm	63 29	42 19	70 36	3.5 1.5
6" 150mm	95 43	74 34	142 64	10.5 4.7
8" 200mm	152 69	116 53	208 94	15.3 7.0
10" 250mm	236 107	182 83	342 156	17.5 7.9
12" 300mm	368 167	314 142	516 234	11.3 5.1
14" 350mm	560 254	-	-	-
16" 400mm	695 315	-	-	-
18" 450mm	890 404	-	-	-
20" 500mm	1105 501	-	-	-

Ordering Information

To order, simply complete the valve order code from the information shown. An ordering example is shown for your reference.

Valve Style

Give valve style code as follows:

VPB = V-Port Ball Valve

Valve Size

Give valve size code as follows:

1 = 1" (25mm)	8 = 8" (200mm)
1.5 = 1.5" (40mm)	10 = 10" (250mm)
2 = 2" (50mm)	12 = 12" (300mm)
2.5 = 2.5" (65mm)	14 = 14" (350mm)
3 = 3" (80mm)	16 = 16" (400mm)
4 = 4" (100mm)	18 = 18" (450mm)
6 = 6" (150mm)	20 = 20" (500mm)

End Connection

Give end connection code as follows:

Flangeless

W1S = Class 150, ISA 75.04 and IEC 534-3-2 F-F
1-12" (25-300mm) valves

Flanged

F1S = Class 150, ISA 75.04, and IEC 534-3-2 F-F
1-20" (25-500mm) valves

F2S = Class 300, ISA 75.04, and IEC 534-3-2 F-F
1-12" (25-300mm) valves

F1L = Class 150, ANSI B16.10, ISO 5752 and EN 558-1 PN 10/16 F-F
1-12" (25-300mm) valves

F1A = Class 150, ANSI B16.10, ISO 5752 and EN 558-1 PN10/16
1-12" (25-300mm) excluding 2.5" (65mm) valve size (Long body)

Body Material

Give body material code as follows:

S3 = 317 stainless steel
S3 bodies must be ordered with S3NH or S3S ball material, S10 or S5 shaft, and S3, S3R, S3S or RT seat material

CS = Carbon Steel
CS bodies must be ordered with S3NH or S3 ball material, S10 or S5 shaft, and S3, S3S, 3R or RT seat material

S2 = 316 stainless steel, Class 300
S2 bodies must be ordered with S3NH or S3S ball material, S10 or S5 shaft, and either S3, S3S, S3R or RT seat material

HC = Hastelloy C
HC body must be ordered with HCNH ball, HC, HCC or TNC shaft, HCRI or RT seat material, and FT, HC, HCVS or HCKS bearings

Trim Combination

Give ball, shaft, and seat material codes as follows:

Ball Material:

S3NH = 317 stainless steel heat treated nickel overlay, 700°F (370°C)
S3S = 317 stainless steel with tungsten carbide overlay, 1000°F(540°C)
HCNH = Hastelloy C with heat treated electroless nickel overlay, 700°F (370°C)

Shaft Material:

S10 = 2205 Duplex stainless steel
S5 = 7-4 PH stainless steel (On Application)
HCC = Hastelloy C - solid bearings (On Application)
TNC = Titanium - solid bearing (On Application)

Seat Material:

S3 = 317 stainless steel heat treated electroless nickel overlay, 700°F (370°C)
S3R = Rigid 317 stainless steel with heat treated nickel overlay, 450° (230°C). Not available on F1L end connections
S3S = Rigid 317 stainless steel with tungsten carbide overlay, 450°F (230° C)
RT = Reinforced PTFE, 500° F (260° C)
S3RI = Rigid 317 stainless steel with heat treated electroless nickel overlay and Inconel spring, 450°F (230°C) (On Application)
S3SI = Rigid 317 stainless steel with tungsten carbide overlay and Inconel spring, 450 F (230°C) (On Application)
HCRI = Rigid Hastelloy C with heat treated electroless nickel overlay and Inconel spring, 450°F (230°C) (On application)

Bearing Material:

FT = 317 stainless steel with wire reinforced PTFE liner, 500°F (260°C)
S9 = 440C stainless steel bearings, 1000° F (540° C)
S9VS = 440C stainless steel bearings with Viton Seal, 450°F (230°C)
SL = Solid Stellite® alloy, 1000° F (540° C)
SLVS = Solid Stellite® with PFA/Viton seal, 450° F (230° C)
SLKS = Solid Stellite® with Kalrez® seal, 600° F (315° C)

Options

Give option codes as follows:

G1 = DIN 10 or BS4504/10 Drilling
G2 = DIN 16 or BS4504/16 Drilling
G3 = DIN 25 or BS4504/25 Drilling (F2S only)
G4 = DIN 40 or BS4504/40 Drilling (F2S only)
J1 = J1S 10 Flange Drilling (F1L or F1S only)
J6 = J1S 16 Flange Drilling (F1L or F1S only)
J2 = J1S 20 Flange Drilling (F2S only)

Ordering Example:

VPB,4,F1L,S3,TC,S3NH-S10-S3-FT*PR-R1A-PC4

Packing Material

Give packing material code as follows:

TC = PTFE chevron, 500° F (260° C)
G2 = Braided carbon graphite, 1000° F (540° C)

Note: Limited by seat temperature rating.

Actuators

Manual Actuators

Lever

Infinite position levers allow positioning of the ball in any desired position. They can be mounted in 90° increments.

An adjustable memory stop is standard on all infinite position levers. It allows the valve to be opened and closed to the same position.

Infinite Position Lever Sizing

Valve Size	Order Code	Shutoff Pressure
1-4" (25-100mm)	LI	285 psi (1965 kPa)

Infinite Position Lever Mounting Positions

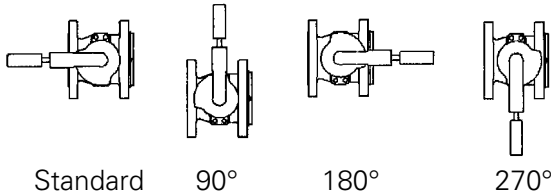

Ordering Example:

VPB,3,F1L,S3,TC,3S-S5-S3-FT*LI

Manual Gear Actuators

Manual gear actuators are available in cast iron construction. They feature sintered bronze bearings on each end of the input shaft for durability and performance.

Cylinder Actuators

PowerRac® Cylinder actuators are available as double-acting or spring return. They feature a high opening torque for on-off applications and also maintain a high operating torque throughout the full stroke for modulating service.



Diaphragm Actuators

Diaphragm actuators may be specified also. They're available with 40, 55, 85, 145 and 250 square inch (0.026m², 0.036m², 0.055m², 0.094m², 0.161m²) sizes and with 20, 35 or 60 psi (140, 240 or 410 kPa) spring options.



Dimensions

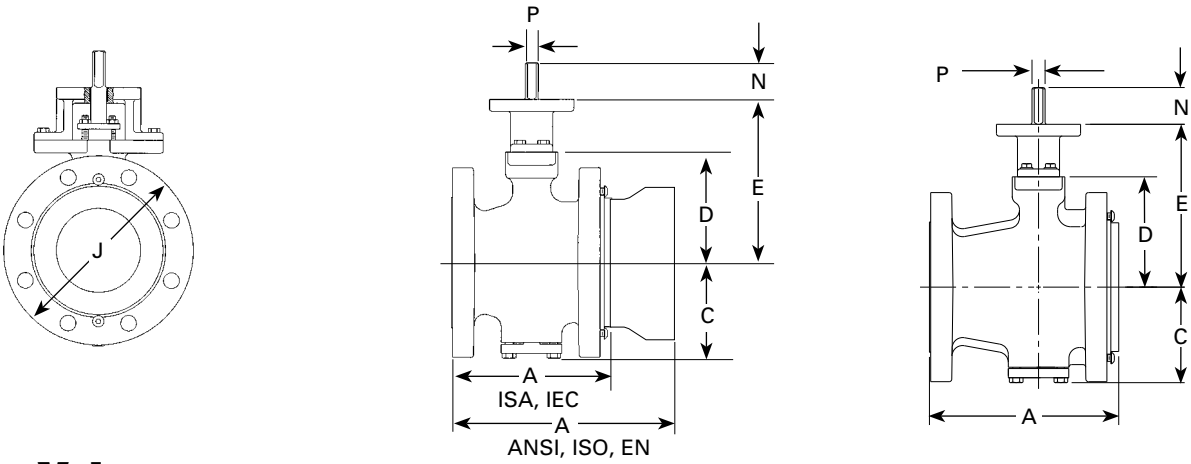

Basic Valve

Valve Size	A		C	D	E	J			N	P Diameter	P Square
	ISA IEC	ANSI ISO EN				Flanged Class 150	Flangeless Class 150	Flange Class 300			
1" 25mm	4.00 102	5.00 127	2.75 70	3.25 83	5.62 143	4.25 108	2.44 62	4.88 124	1.75 44	.62 16	.50 13
1.5" 40mm	4.50 114	6.50 165	2.94 75	3.47 88	5.84 148	5.00 127	3.06 78	6.12 155	1.75 44	.62 16	.50 13
2" 50mm	4.88 124	7.00 178	3.22 82	3.75 95	6.12 155	6.00 152	3.81 97	6.50 165	1.75 44	.62 16	.50 13
2.5" 65mm	5.50 140	7.50 191	3.75 95	4.44 113	6.94 176	7.00 178	4.38 111	7.50 190	1.75 44	.75 19	.62 16
3" 80mm	6.50 165	8.00 203	4.00 102	4.69 119	7.19 183	7.50 191	5.19 132	8.25 210	1.75 44	.75 19	.62 16
4" 100mm	7.62 194	9.00 229	4.56 116	5.25 133	7.75 197	9.00 229	6.38 162	10.00 254	1.75 44	.75 19	.62 16
6" 150mm	9.00 229	10.50 267	5.72 145	6.50 165	9.50 241	11.00 279	8.50 216	12.50 317	1.75 44	1.25 32	.94 24
8" 200mm	9.56 243	11.50 292	7.28 185	8.12 206	11.12 282	13.50 343	10.62 270	15.00 381	1.75 44	1.50 38	1.19 30
10" 250mm	11.69 297	13.00 330	8.91 226	9.50 241	13.38 340	16.00 406	13.12 333	17.50 444	1.75 44	2.00 51	1.62 41
12" 300mm	13.31 338	14.00 356	9.91 252	10.50 267	14.38 365	19.00 483	15.38 391	20.50 521	1.75 44	2.00 51	1.62 41
14" 350mm	15.75 400	—	10.86 276	11.47 291	15.34 390	21.00 533	—	—	1.75 44	2.00 51	1.62 41
16" 400mm	15.75 400	—	13.25 337	14.06 375	18.56 471	23.50 597	—	—	1.75 44	2.50 64	1.94 49
18" 450mm	18.00 457	—	14.44 367	15.25 387	19.75 502	25.00 635	—	—	1.75 44	2.50 64	1.94 49
20" 500mm	20.00 508	—	15.56 395	16.38 416	20.38 518	27.50 686	—	—	1.75 44	2.50 64	1.94 49

Lever

Valve Size	Dimensions	
	K	R
16" 400mm	11.25 286	1.75 44
16" 400mm	15.25 387	1.75 44

Inch
Millimeter

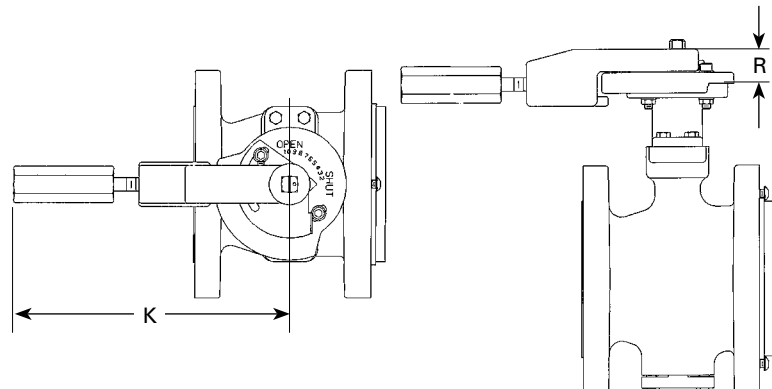

Note: All dimensions are subject to change without notice. Request certified drawings for use in preparing piping layouts.

Tie Bolt & Bolt Lengths — Flangeless Valves

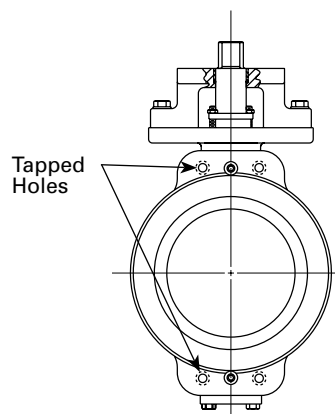
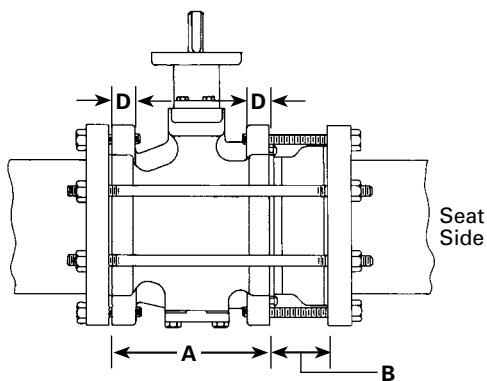

Valve Size	A	B		D
		F1L	F1S, F2S	
		ANSI, ISO & EN Face-to-Face	ISA & IEC Face-to-Face	
1" 25mm	3.69 94	1.31 33	0.31 8	.44 11
1.5" 40mm	4.19 106	2.31 59	0.31 8	.56 14
2" 50mm	4.57 116	2.43 62	0.31 8	.62 16
2.5" 65mm	4.94 125	2.56 66	0.56 15	.69 18
3" 80mm	5.94 151	2.06 52	0.56 15	.75 19
4" 100mm	7.06 179	1.94 50	0.56 15	.94 24
6" 150mm	8.50 216	2.00 51	0.50 13	1 25
8" 200mm	9.06 230	2.44 62	0.50 13	1.12 28
10" 250mm	11.07 281	1.93 49	0.62 16	1.19 30
12" 300mm	12.69 322	1.31 33	0.62 16	1.25 32

Valve Size	Quantity of Tapped Holes/Flange				
	ANSI 150	PN 10	PN 16	JIS 10	JIS 16
1" 25mm	—	—	—	—	—
1.5" 40mm	—	—	—	—	—
2" 50mm	—	—	—	—	4
2.5" 65mm	—	—	—	—	4
3" 80mm	—	—	—	4	4
4" 100mm	—	—	—	4	4
6" 150mm	—	—	—	—	4
8" 200mm	—	—	4	4	4
10" 250mm	4	4	4	4	4
12" 300mm	4	4	4	4	4

Tie Bolt Length

To determine the minimum tie bolt length on flangeless valves:

- add body length (dimension A from chart)
- add seat retainer length (dimension B from chart)
- add the two adjoining pipe flange thicknesses (customer determined)
- add the thicknesses of the two nuts (customer determined)

Bolt Length for Tapped Holes – Side Opposite Seat

To determine the minimum bolt length on flangeless valves for the side opposite the seat:

- add the tapped lug thickness (dimension D from chart)
- add the adjoining pipe flange thickness (customer determined)

Bolt Length for Tapped Holes – Seat Side

To determine the minimum bolt length on the seat side of flangeless valves:

- add the tapped lug thickness (dimension D from chart)
- add the seat retainer length (dimension B from chart)
- add the adjoining pipe flange thickness (customer determined)

Bolt Length for Tapped Holes – Side Opposite Seat

To determine the minimum bolt length on the side opposite the seat for those valves with tapped holes:

- add the valve flange thickness (dimension D from chart)
- add adjoining pipe flange thickness (customer determined)

Bolt Length for Tapped Holes – Seat Side

To determine the minimum bolt length on the seat side for those valves with tapped holes:

- add the valve flange thickness (dimension D from chart)
- add seat retainer length (dimension B from chart)
- add adjoining pipe flange thickness (customer determined)

Bolt Length – Side Opposite Seat

To determine the minimum bolt length on the side opposite the seat:

- add the valve flange thickness (dimension D from chart)
- add the adjoining pipe flange thickness (customer determined)
- add nut thickness (customer determined)

Bolt Length – Seat Side

To determine the minimum bolt length on the seat side of flanged valves:

- add the valve flange thickness (dimension D from chart)
- add seat retainer length (dimension B from chart)
- add adjoining pipe flange thickness (customer determined)
- add nut thickness (customer determined)

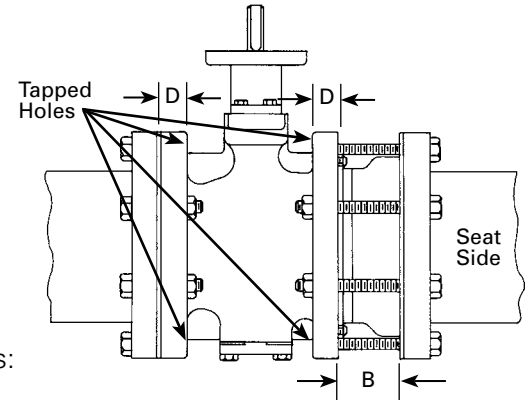

Bolt Lengths - Flanged Valves

Valve Size	Quantity of Tapped Holes/Flange					
	ANSI 150	ANSI 300	PN 10/16	PN 25/40	JIS 10	JIS 16/20
1" 25mm	—	—	—	—	4	4
1.5" 40mm	—	—	—	—	4	4
2" 50mm	—	4	—	—	4	4
2.5" 65mm	—	4	—	4	4	4
3" 80mm	—	—	—	—	8	4
4" 100mm	—	—	—	—	8	8
6" 150mm	—	4	—	—	8	4
8" 200mm	—	4	—	4	12	4
10" 250mm	—	—	—	—	12	—
12" 300mm	—	—	—	—	16	4
14" 350mm	—	—	—	—	16	—
16" 400mm	—	—	—	—	16	—
18" 450mm	—	—	—	—	—	—
20" 500mm	—	—	—	—	—	—

Valve Size	B		D	
	F1L	F1S, F2S	Flange Thickness	
	ANSI, ISO & EN Face-to-Face	ISA & IEC Face-to-Face	Class 150	Class 300
1" 25mm	1.31 33	0.31 8	.44 11	.69 18
1.5" 40mm	2.31 59	0.31 8	.56 14	.81 21
2" 50mm	2.43 62	0.31 8	.62 16	.88 22
2.5" 65mm	2.56 66	0.56 15	.69 18	1 25
3" 80mm	2.06 52	0.56 15	.75 19	1.12 28
4" 100mm	1.94 50	0.56 15	.94 24	1.25 32
6" 150mm	2.00 51	0.50 13	1 25	1.44 37
8" 200mm	2.44 62	0.50 13	1.12 28	1.62 41
10" 250mm	1.93 49	0.62 16	1.19 30	1.88 48
12" 300mm	1.31 33	0.62 16	1.25 32	2 51
14" 350mm	—	0.87 22	1.38 35	—
16" 400mm	—	1.12 28	1.44 37	—
18" 450mm	—	1.12 28	1.56 40	—
20" 500mm	—	1.12 28	1.69 43	—

Sales and Service

For information about our worldwide locations, approvals, certifications and local representative:

Web Site: www.dezurik.com E-Mail: info@dezurik.com



250 Riverside Ave. N. Sartell, Minnesota 56377 • Phone: 320-259-2000 • Fax: 320-259-2227

DeZURIK reserves the right to incorporate our latest design and material changes without notice or obligation. Design features, materials of construction and dimensional data, as described in this bulletin, are provided for your information only and should not be relied upon unless confirmed in writing by DeZURIK. Certified drawings are available upon request.