

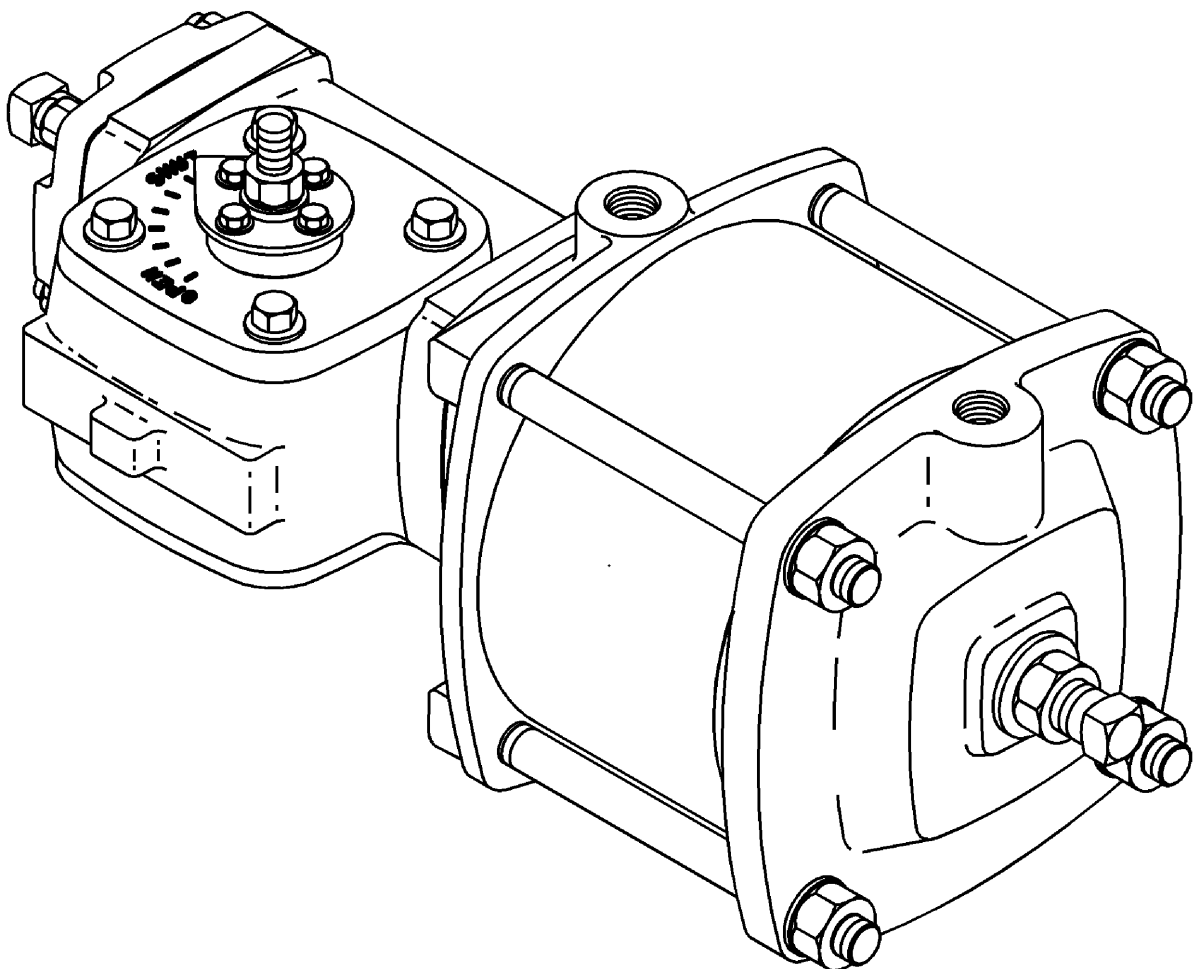

DeZURIK R1 AND R2 POWERRAC™ ACTUATORS



Instruction D10268
June 2011

DeZURIK

R1 and R2 POWERRAC™ Actuators

Instructions

These instructions provide installation, operation, and maintenance information for DeZURIK R1 AND R2 POWERRAC™ Actuators. They include procedures which, when carefully followed, help to ensure satisfactory performance of these actuators. All warnings and cautions included in these instructions must be followed to avoid personal injury and equipment damage.

These instructions are intended for use by personnel who are responsible for installation, operation or maintenance of R1 and R2 POWERRAC™ actuators.

Safety Messages

All safety messages in the instructions are flagged with an exclamation symbol and the word Caution, Warning or Danger. These messages indicate procedures that must be followed exactly to avoid equipment damage, personal injury or death. Safety label(s) on the product indicate hazards that can cause equipment damage, personal injury or death.

Safety label(s) on the product indicate hazards that can cause equipment damage, personal injury or death. If a safety label becomes difficult to see or read, or if a label has been removed, please contact DeZURIK for replacement label(s).



WARNING!

Personnel involved in the installation or maintenance of valves should be constantly alert to potential emission of pipeline material and take appropriate safety precautions. Always wear suitable protection when dealing with hazardous pipeline materials. Handle valves, which have been removed from service with suitable protection for any potential pipeline material in the valve.

Inspection

Your POWERRAC™ Actuator has been packaged to provide protection during shipment; however, it can be damaged in transport. Carefully inspect the unit for damage upon arrival and file a claim with the carrier if damage is apparent.

Parts

Recommended spare parts are listed on the assembly drawing. These parts should be stocked to minimize downtime.

Order parts from your DeZURIK sales representative, or directly from DeZURIK. When ordering parts, please include the 7-digit part number and 4-digit revision number (example: **9999999R000**) located on the data plate attached to the valve assembly. Also include the part name, the assembly drawing number, the balloon number and the quantity stated on the assembly drawing.

DeZURIK Service

DeZURIK service personnel are available to install, maintain and repair all DeZURIK products. DeZURIK also offers customized training programs and consultation services.

For more information, contact your local DeZURIK sales representative or visit our website at www.dezurik.com.

Table of Contents

Description - - - - -	4
Installation - - - - -	4
Operation- - - - -	5
Lubrication - - - - -	6
Position Stops - - - - -	7
Removing Actuator - - - - -	8
Actuator Disassembly - - - - -	8
Double-Acting Cylinder Disassembly - - - - -	10
Spring-Return Cylinder Disassembly - - - - -	11
Spring-Return Cylinder Reassembly - - - - -	12
Double-Acting Cylinder Reassembly - - - - -	13
Double-Acting Actuator Reassembly - - - - -	14
Spring-Return Actuator Reassembly - - - - -	18
Mounting Actuator - - - - -	20
Changing from Double-Acting to Spring-Return Spring-to-Close- - - - -	22
Changing from Double-Acting to Spring-Return Spring-to-Open- - - - -	22
Changing from Spring-Return Spring-to-Close to Double-Acting- - - - -	24
Changing from Spring-Return Spring-to-Open to Double-Acting- - - - -	24
Reversing Spring Action - - - - -	24
Changing Mounting Position - - - - -	24
Lockable Model - - - - -	25
<i>Unlocked Condition</i> - - - - -	25
<i>Locked Closed Position</i> - - - - -	25
<i>Locked Open Position</i> - - - - -	26
Troubleshooting - - - - -	28

Description

The DeZURIK R1 and R2 PowerRac™ actuators are quarter-turn, enclosed rack and gear cylinder actuators. The R1 and R2 PowerRac™ actuator are used for on-off or modulating control on valves that have a square or double-D shaft connection.

The R number designates the radius of the actuator gear. A choice of cylinder diameters is offered—4 and 6" (100 mm and 150 mm) on the R1 actuator, and 6 and 8" (150 mm and 200 mm) on the R2 actuator.

The R1 and R2 PowerRac™ actuator are available as double-acting actuators or as a spring-return actuators, either spring-to-open or spring-to-close. The spring action may be reversed by ordering the alternate spring-return cylinder assembly, and exchanging the positions of the two cylinders. The cylinder mounting interface is the same for all PowerRac™ actuators.

A lockable model of The DeZURIK PowerRac™ actuator is also available. Operation of the lockable model is described on page 19.

These instructions include information for all three actuator configurations, and for changing from one to another. See Figure 1 to identify the applicable configuration; refer to Figures 2 through 4 to identify the components within each configuration.

Installation

Pneumatic connections are required as shown in Figure 1, and as described below. All cylinder port connections are ¼" NPT.

Double-Acting Actuator

The double-acting actuator requires two pneumatic connections—one to each port on opposite ends of the cylinder. Air to the connection closest to the actuator drives the actuator clockwise, towards the “shut” position on the dial; air to the connection farthest from the actuator drives the actuator counterclockwise, towards the “open” position on the dial.

Spring-Return Actuator

The spring-return actuator requires one pneumatic connection—to the fitting on the tubing that connects the two cylinders. With a spring-to-open spring cartridge, air to the connection drives the actuator clockwise, towards the “shut” position on the dial; with a spring-to-close spring cartridge, air to the connection drives the actuator counterclockwise, towards the “open” position on the dial.

As the spring-return actuator is cycled, air is alternately exhausted and drawn in through two breathers—one on each cylinder as shown in Figure 1. The breathers must be protected from water because water inside of the actuator will cause sticking and premature wear of the internal components. If the actuator is located outdoors or in an area that will be hosed down, the breathers must be oriented vertically. The “umbrella” top of the breathers will then prevent water from being drawn in through the breathers. In locations that are submerged or subject to flooding, the breathers must be removed and remotely piped to a protected location.

Installation (continued)

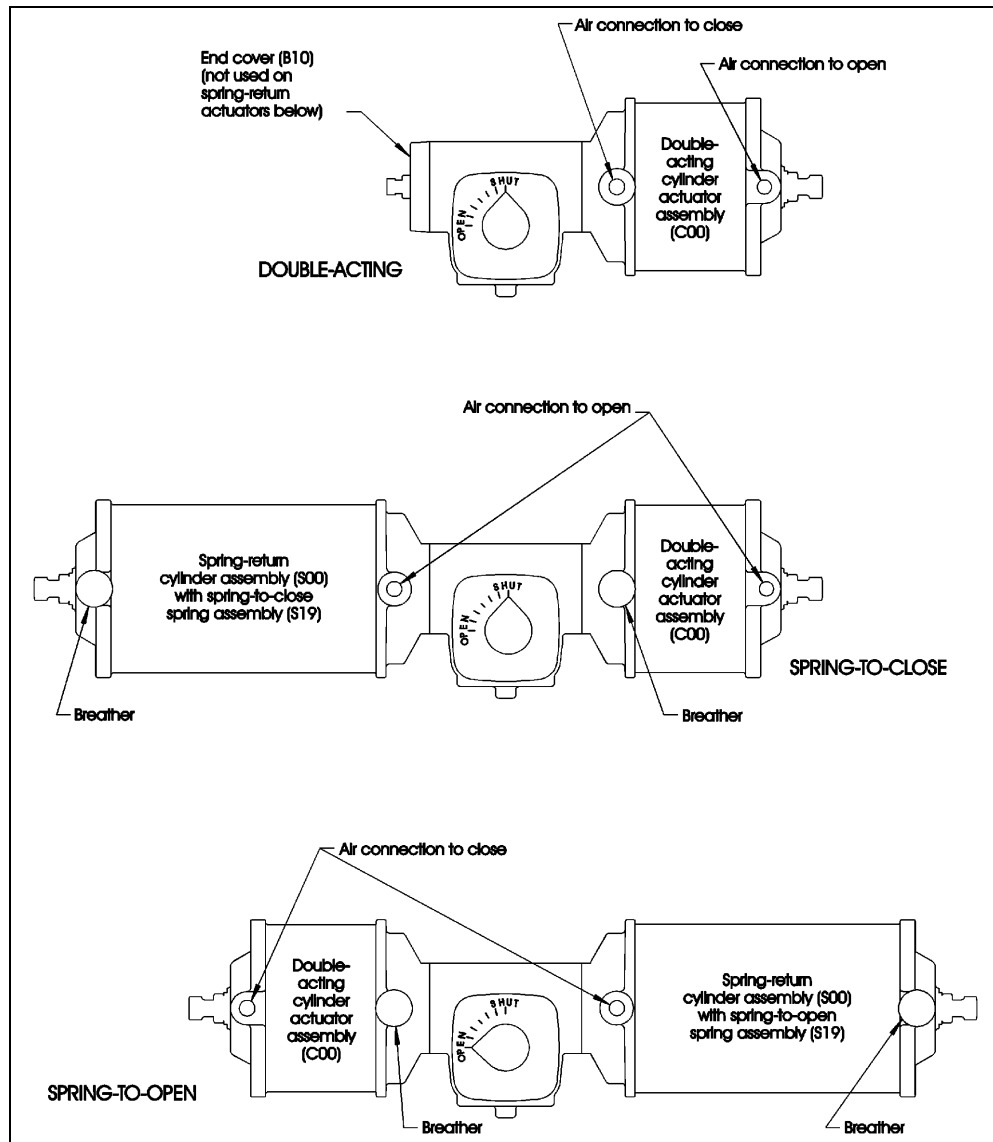

Figure 1—R1 and R2 PowerRac™ Configurations

Operation

The R1 and R2 PowerRac™ actuator is powered pneumatically, and rotates 90° between the open and closed positions, in the direction as described above.

The double-acting cylinder is sized for 60 psi or 80 psi (415 kPa or 550 kPa), and the spring-return cylinder is sized for a 60 psi (415 kPa) spring only.

All cylinders are limited to 100 psi (690 kPa) maximum.

Lubrication

The actuator has been lubricated at the factory and requires no routine lubrication. If the actuator is disassembled (see Figures 2 thru 4 for actuator parts identification);

apply a paint-like coating using one of these lubricants:

- Dow Corning Molykote No. 44 (**recommended**)
- Shell Retinax AM (alternate)
- Shell Lithall MDS (alternate)

to the following surfaces:

- Inside diameter of cylinder tube (C6 or S6)
- Chamfer for cylinder tube on cylinder cap (C11 or S11) and cylinder head of housing (C1 or S1)
- O-rings (C5 or S5, C8 or S8, and C14 or S14) and grooves
- Seals (C3 or S3 and C9 or S9) and grooves
- Thread seal (C16 or S16)
- Inside diameter of bearing (C2 or S2) located in cylinder head housing.
- Outside diameter of piston rod (C4 or S4).

apply a paint-like coating using one of these lubricants:

- Keystone Zeniplex-1 (**recommended**)
- Amoco Amolith Grease #1-EP (alternate)
- Amsoil GHD (alternate)
- Mobil Mobilux EP 1 (alternate)
- Petro-Canada Vultrex MPG EP 1 (alternate)
- Shell Alvania EP 1 (alternate)
- Texaco Multifak EP 1 (alternate)

to the following surfaces:

- Flat side of rack bearing (B3), before assembly
- Back side of rack (B5) that contacts rack bearing, before assembly
- Both bearing hubs of gear (B8), before assembly
- Top cover O-ring (B10) and groove in top cover (B11), before assembly
- Teeth in rack (B5) and gear (B8) after assembly (so witness marks are visible during assembly).

Position Stops

The adjustable open and closed position stops prevent the actuator from rotating beyond the open and closed positions of the valve.

Double Acting Actuator

The closed position stop is located in the cylinder cap, and the open position stop is located in the actuator end cover.

Spring-Return Actuators

With a spring-to-open spring cartridge, the closed position stop is located in the spring cylinder (the longer cylinder), and the open position stop is located in the other (shorter) cylinder.

With a spring-to-close spring cartridge, the open position stop is located in the spring cylinder (the longer cylinder), and the closed position stop is located in the other (shorter) cylinder.

Adjustments

If the actuator is factory-mounted on the valve, the stops are preset, and do not require further adjustment. If the actuator is not factory-mounted on the valve, or if the actuator is removed and/or disassembled, the stops will require adjustment as described below. Refer to the Valve Instructions for closed-position information, and adjust the stops after the actuator is mounted on the valve.

The adjustable stops are square head screws, secured with jam nuts, and located in the extreme ends of the actuator as shown in Figures 1 through 4.

To adjust either stop:

1. Loosen the jam nut, and turn the screw counterclockwise to increase the stroke, or clockwise to decrease the stroke.
2. After the stop is adjusted to the desired position, hold the screw from turning, and tighten the jam nut to the torque value shown in Table A.

Jam Nut	Carbon Steel		Stainless Steel	
	Foot Pounds	Newton Meters	Foot Pounds	Newton Meters
1/2" Nut on 4" Cylinder Cap	63 ± 8	85 ± 11	38 ± 5	52 ± 7
5/8" Nut on 6" Cylinder Cap	130 ± 20	176 ± 27	77 ± 10	104 ± 14
3/4" Nut on 8" Cylinder Cap	230 ± 30	312 ± 41	140 ± 18	190 ± 24
5/8" Nut on End Cover	130 ± 20	176 ± 27	77 ± 10	104 ± 14

Removing Actuator

Refer to Figure 2 for component identification.



WARNING!

Flow in the pipeline with the actuator removed can allow the valve to slam closed and cause personal injury and/or damage to the flow system. Shut down the flow in the pipeline before removing the actuator from the valve.

1. Shut down the flow in the pipeline.



WARNING!

Moving parts from unexpected operation of a powered actuator can cause personal injury or equipment damage. Disconnect and lock out power to the actuator before servicing.

2. Disconnect and lockout the pneumatic power to the actuator to prevent accidental operation of the actuator.
3. Release the collet assembly (B9) from the valve shaft by loosening the jam nut (B9D) and the hex socket set screw (B9A) that extends through the pointer (B9F) on top of the actuator.
4. Remove the four mounting screws (B26) that fasten the actuator to the valve.
5. Remove the actuator from the valve by lifting the actuator from the valve shaft.

Actuator Disassembly

Refer to Figures 2, 3 and 4 for component identification.

1. Remove the four pointer screws (B9G), and remove the collet assembly (B9), together with the pointer (B9F) from the actuator.
2. Remove the four top cover screws (B15) and remove the top cover (B11).
3. Remove the top cover gasket (B13) and the O-ring (B10).
4. Remove the gear (B8).
5. Remove the four cylinder assembly nuts (B20) and lockwashers (B19), and remove the cylinder assembly (C00) and gasket (B16).
6. Remove the rack screw (B7), the lockwasher (B6), and separate the rack (B5) from the piston rod (C4).
7. Remove the rack bearing (B3) from the pin (B4).
8. If the actuator is double-acting, remove the four end cover nuts (B20) the lockwashers (B19), the end cover (B17) and gasket (B16).
9. If the actuator is spring-return, remove the four cylinder assembly nuts (B20) lockwashers (B19), the spring-return cylinder assembly (S00) and the gasket (B16).

Actuator Disassembly (continued)

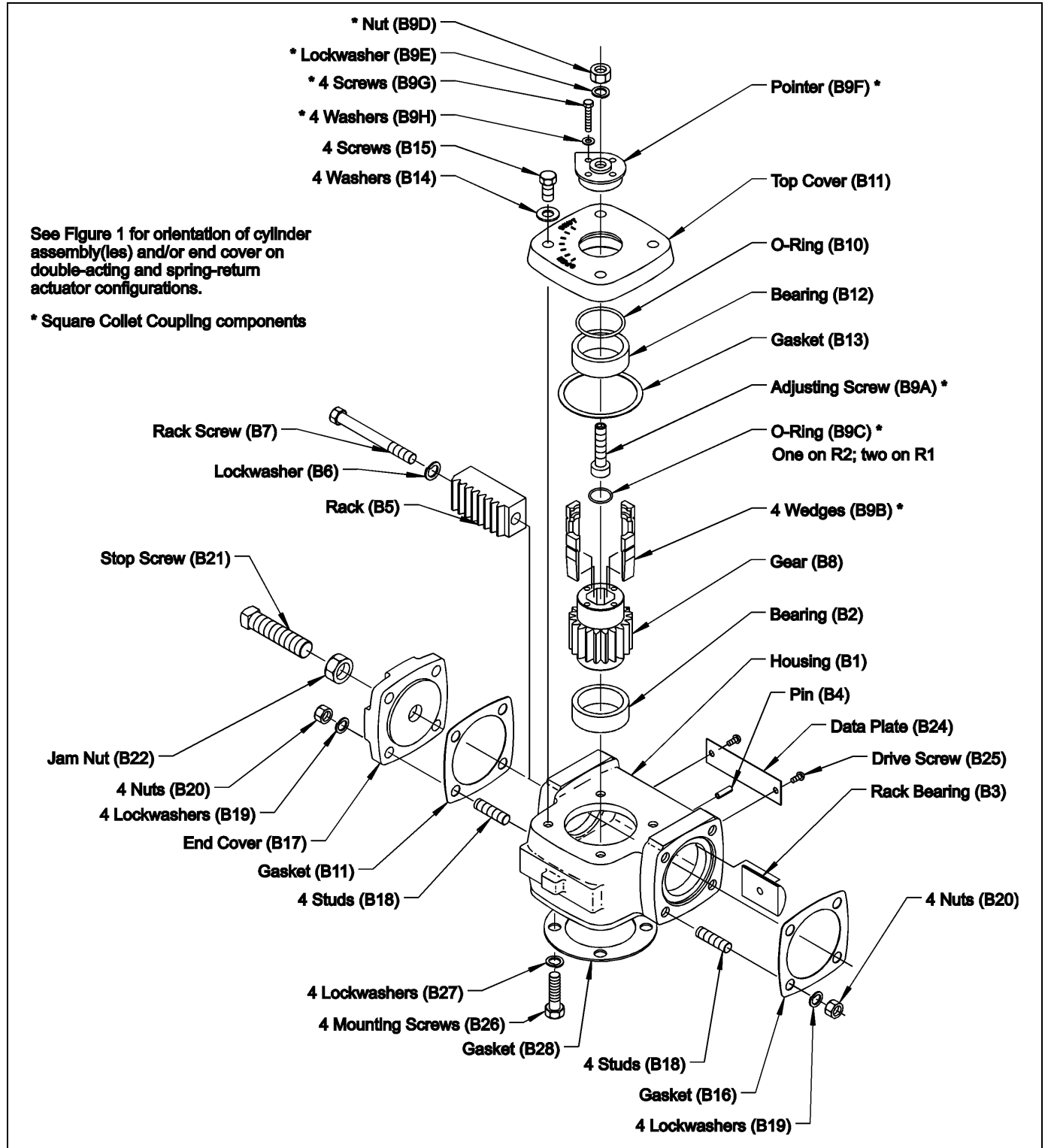

Figure 2—Actuator Assembly, Less Cylinders

Double-Acting Cylinder Disassembly

Refer to Figure 3 for component identification.

1. Remove the tie rod nuts (C15) and washers (C13) from the tie rods (C12).
2. Remove the cylinder cap (C11).
3. Push the piston rod (C4) through the cylinder head (C1), and remove the piston (C7) and piston rod (C4).
4. Remove the piston nut (C10), the piston (C7), and the O-ring (C14) from the piston rod (C4).
5. Remove the cylinder tube (C6) from the cylinder head (C1).
6. Remove the piston seal (C9) and the O-ring (C8) from the piston (C7).
7. Remove the piston rod seal (C3) from the cylinder head (C1).
8. Remove the two cylinder tube O-rings (C5) from the cylinder head (C1) and from the cylinder cap (C11).

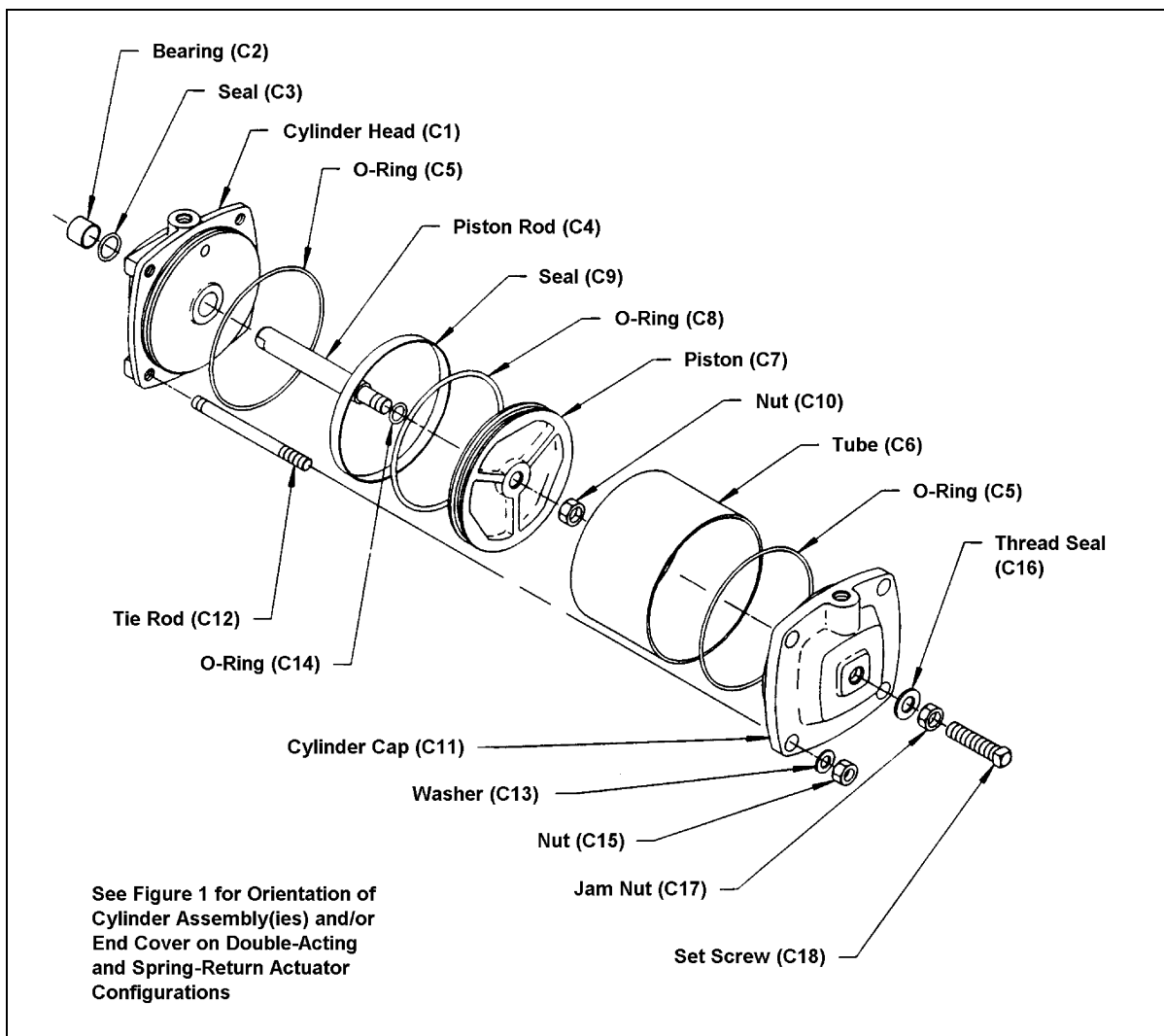

Figure 3—Double-Acting Cylinder Assembly

Spring-Return Cylinder Disassembly

Refer to Figure 4 for component identification.



DANGER!

The spring assembly (S19) contains a compressed spring that can cause death or personal injury if the cylinder tie rod nuts are removed while the spring force is on the tie rod nuts. DO NOT REMOVE THE CYLINDER TIE ROD NUTS UNLESS THE SPRING FORCE DECREASES TO ZERO!

1. Loosen the tie rod nuts (S15) on the tie rods (S12).

Note: Force from the spring assembly will be felt during the first few turns of the nuts. As the cylinder tie rod nuts are loosened, the force from the spring assembly must decrease to zero before the nuts can be removed from the tie rods. The nuts and washers (S13) may be removed safely after the force from the spring assembly decreases to zero. **If the spring force does not decrease to zero, re-tighten the nuts and contact the factory.**

2. Remove the cylinder cap (S11).
 3. Push the piston rod (S4) through the cylinder head (S1) so that the spring assembly (S19) is accessible.
-



DANGER!

The spring assembly (S19) contains a compressed spring that can cause death or personal injury if the assembly is taken apart. DO NOT DISASSEMBLE THE SPRING ASSEMBLY!

4. Remove the spring assembly (S19) carefully from the cylinder tube (S6).

Note: Do not damage the cylinder wall with the spring assembly during this step. **Do not disassemble the spring assembly!**

5. Remove the cylinder tube (S6), the piston (S7) and the piston rod (S4) from the cylinder head (S1).
6. Remove the piston (S7) and the piston rod (S4) from the cylinder tube (S6).
7. Remove the piston nut (S10), the piston (S7) and the O-ring (S14) from the piston rod (S4).
8. Remove the piston seal (S9) and the O-ring (S8) from the piston (S7).
9. Remove the piston rod seal (S3) from the cylinder head (S1).
10. Remove the two cylinder tube O-rings (S5) from the cylinder head (S1) and from the cylinder cap (S11).

Spring-Return Cylinder Reassembly

Clean and inspect all parts before reassembly. Refer to Figure 4 for component identification. See Figure 1 for orientation of cylinder assembly and end cover on spring-to-open and spring-to-close actuator configurations. See “*Lubrication*” section for lubricating requirements.

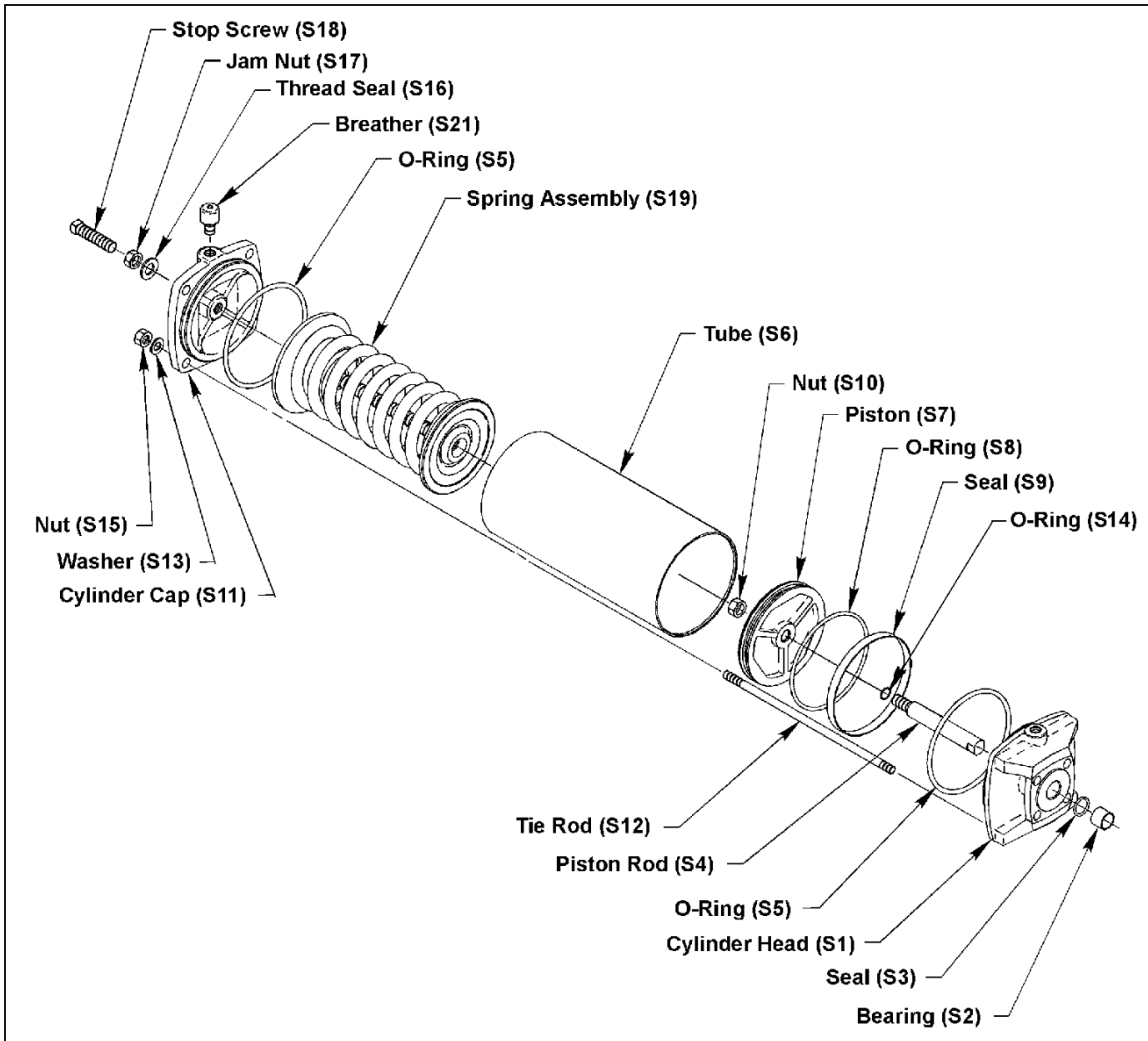

Figure 4—Cylinder Assembly

1. Replace worn parts, especially sealing components such as O-rings, other seals, and the cylinder tube.
2. Lubricate O-rings, other seals, and the cylinder tube walls.
3. With the O-ring and groove toward the piston rod, place the O-ring (S14), the piston (S7), and the nut (S10) on the piston rod (S4).

Spring-Return Cylinder Reassembly *(continued)*

4. Tighten the nut to 45 ± 5 foot pounds (61 ± 7 Nm).
5. Place the O-ring (S8) in the smaller groove of the piston (S7). Place the piston seal (S9) in the larger groove of the piston as far around the circumference as possible without stretching the seal. Angle the remaining portion of the seal, and carefully slip it over the edge of the piston and into the groove.
6. Place the piston rod seal (S3) in the cylinder head (S1).
7. Push the piston rod (S4) through the cylinder head (S1) so that the piston (S7) is against the cylinder head.
8. Place the two cylinder tube O-rings (S5) in the groove in the cylinder head (S1) and in the groove in the cylinder cap (S11).
9. Using care to avoid damage to the piston seal (S9), replace the cylinder tube following the appropriate steps for the size:
 - a. If the cylinder tube (S6) diameter is 6 or 8" (150 mm), place the cylinder tube over the piston (S7) at about a 45° angle. Carefully square the cylinder tube into alignment with the piston, and push the cylinder tube into position on the cylinder head (S1).
 - b. If the cylinder tube diameter is 4" (100 mm), push the cylinder tube on straight, without the angle.
10. Note the end of the spring assembly (S19) that has a 1 1/8" (29 mm) diameter machined hole. With the hole toward the piston (S7), carefully insert the spring assembly into the cylinder tube (S6) so that the hole fits over the piston nut (S10). Do not damage the cylinder wall with the spring assembly during this step.
11. Align the holes in the cylinder cap (S11) with the tie rods (S12) and insert the cylinder cap into the cylinder tube (S6). Place the tie rod nuts (S15) and washers (S13) on the tie rods. If the cylinder tube diameter is 4" (100 mm), tighten the nuts (5/16") to 12 ± 2 foot pounds (16 ± 3 Nm); if the cylinder tube diameter is 6" (150 mm), tighten the nuts (1/2") to 16 ± 2 foot pounds (22 ± 3 Nm).

Double-Acting Cylinder Reassembly

Clean and inspect all parts before reassembly. Refer to Figure 3 for component identification. See "Lubrication" section for lubricating requirements.

1. Replace worn parts, especially sealing components such as O-rings, other seals, and the cylinder tube.
2. Lubricate O-rings, other seals, and the cylinder tube walls.
3. With the O-ring and groove toward the piston rod, place the O-ring (S14), the piston (S7), and the nut (S10) on the piston rod (S4).
4. Tighten the nut to 45 ± 5 foot pounds (61 ± 7 Nm).
5. Place the O-ring (S8) in the smaller groove of the piston (S7). Place the piston seal (S9) in the larger groove of the piston as far around the circumference as possible without stretching the seal. Angle the remaining portion of the seal, and carefully slip it over the edge of the piston and into the groove.

Double-Acting Cylinder Reassembly *(continued)*

6. Place the piston rod seal (S3) in the cylinder head (S1).
7. Push the piston rod (S4) through the cylinder head (S1) so that the piston (S7) is against the cylinder head.
8. Place the two cylinder tube O-rings (S5) in the groove in the cylinder head (S1) and in the groove in the cylinder cap (S11).
9. Using care to avoid damage to the piston seal (S9), replace the cylinder tube following the appropriate steps for the size:
 - a. If the cylinder tube (S6) diameter is 6 or 8" (150 mm), place the cylinder tube over the piston (S7) at about a 45° angle. Carefully square the cylinder tube into alignment with the piston, and push the cylinder tube into position on the cylinder head (S1).
 - b. If the cylinder tube diameter is 4" (100 mm), push the cylinder tube on straight, without the angle.
10. Align the holes in the cylinder cap (S11) with the tie rods (S12) and insert the cylinder cap into the cylinder tube (S6). Place the tie rod nuts (S15) and washers (S13) on the tie rods. If the cylinder tube diameter is 4" (100 mm), tighten the nuts (5/16") to 12 ± 2 foot pounds (16 ± 3 Nm); if the cylinder tube diameter is 6" (150 mm), tighten the nuts (1/2") to 16 ± 2 foot pounds (22 ± 3 Nm).

Double-Acting Actuator Reassembly

Clean and inspect all parts before reassembly. Refer to Figure 3 for component identification. See "Lubrication" section for lubricating requirements.

1. Replace worn parts, especially sealing components such as O-rings and gaskets.
2. Lubricate the following surfaces:
 - The flat side of the rack bearing (B3)
 - Both bearing hubs of the gear (B8)
 - The top cover O-ring (B10) and the groove in the top cover (B11)
 - Both sides of the four wedges in the collet assembly (B9), and the mating four surfaces inside of the gear (B8).
 - The teeth in the rack (B5) and in the gear (B8)
3. Place the rack bearing (B3) on the pin (B4).

Note: A dab of grease on the curved side of the bearing will help hold it in place.
4. Note the witness mark(s) on the teeth near one end of the rack (B5). Assemble the end of the rack opposite the witness marks to the end of the double-acting piston rod (C4) with the rack screw (B7) and lockwasher (B6). Do not tighten the screw until step number 10.
5. With the pneumatic connections facing upwards (towards the top of the actuator), mount the cylinder assembly (C00) and the gasket (B16) to the housing (B1). Use the four studs (B18) on the left-hand side of the housing, as viewed when facing the data plate (B24) on the housing. Place the nuts (B20) and lockwashers (B19) on the studs. Tighten the nuts to 26 ± 3 foot pounds (35 ± 4 Nm) if carbon steel, or to 15 ± 2 foot pounds (20 ± 3 Nm) if stainless steel.

Double-Acting Actuator Reassembly *(continued)*

6. With the four tapped holes facing upwards, place the gear (B8) into the housing bearing (B2), and engage the gear teeth with the rack (B5) following the procedure applicable to your configuration:
 - **R1 Actuator on a Square valve shaft**

One tooth on the rack is marked with a raised dot that must mesh between two teeth with similar dots on the R1 gear, as shown in Figure 5.
 - **R2 Actuator on a Square valve shaft**

One tooth on the gear is marked with a raised dot that must mesh between two teeth with similar dots on the R2 rack, as shown in Figure 5.
 - **R1 Actuator on a Double-D valve shaft**

One tooth on the rack is marked with a raised dot that must mesh between one of two pair of teeth with similar dots on the R1 gear. The correct pair of teeth to use is shown in Figure 5, as determined by the desired actuator mounting position on the valve. The optional mounting positions are shown on the Valve Installation Drawing.
 - **R2 Actuator on a Double-D valve shaft**

Two non-adjacent teeth on the gear are marked with a raised dot. One of the marked gear teeth must mesh between the two adjacent teeth with similar dots on the R2 rack. The correct gear tooth to use is shown in Figure 5, as determined by the desired actuator mounting position on the valve. The optional mounting positions are shown on the Valve Installation Drawing.

Double-Acting Actuator Reassembly (continued)

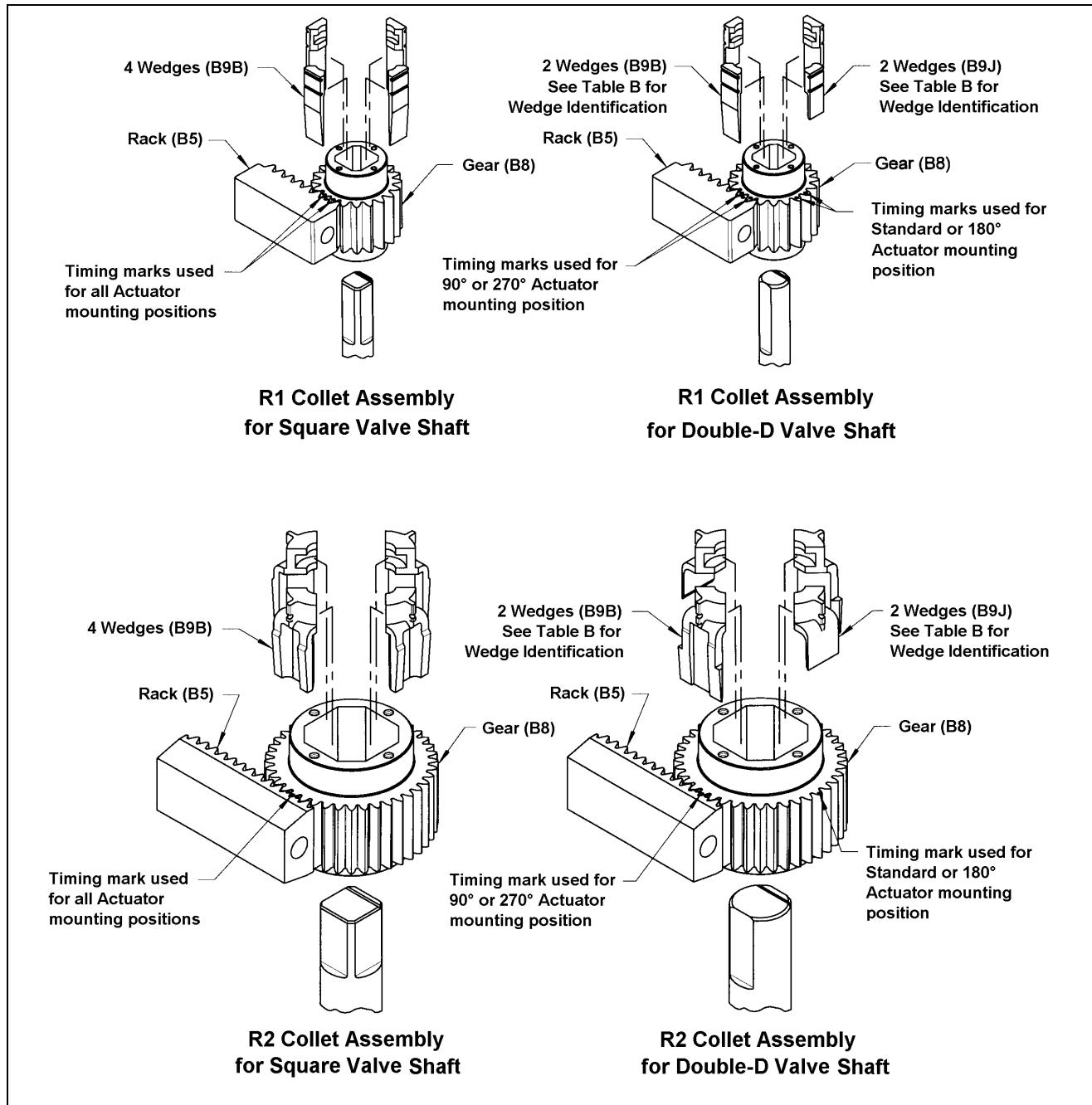

Figure 5—Collet Assembly and Gear Alignment

7. Place the O-ring (B10) in the groove of the top cover (B11).
8. Mount the top cover (B11) and gasket (B13) to the housing (B1) with the four screws (B15) and washers (B14). Tighten the nuts to 26 ± 3 foot pounds (35 ± 4 Nm) if carbon steel, or to 15 ± 2 foot pounds (20 ± 3 Nm) if stainless steel.
9. Place the actuator in the open position (with the piston rod C4 extended into the actuator) before the next step.

Double-Acting Actuator Reassembly *(continued)*

10. tighten the rack screw (B7):
 - On the R1 model, tighten the screw (3/8") to 35 ± 5 foot pounds (47 ± 7 Nm)
 - On the R2 model, tighten screw (1/2") to 89 ± 12 foot pounds (121 ± 16 Nm).
11. Turn the jam nut (B22) onto the stop screw (B21), and turn the stop screw into the center hole in the end cover (B17) until the end of the stop screw protrudes about 1/4" (6 mm) through the end cover. Turn the jam nut finger tight.
12. Mount the end cover (B17) and the gasket (B16) to the housing studs (B18) with the four nuts (B20) and lockwashers (B19). Tighten the nuts to 26 ± 3 foot pounds (35 ± 4 Nm) if carbon steel, or to 15 ± 2 foot pounds (20 ± 3 Nm) if stainless steel.
13. Turn the adjusting screw (B9A) in the collet assembly (B9) so that the four wedges are about 1/32" (0.8 mm) from the bottom of the pointer (B9F).
14. With the actuator in the open or closed position, place the collet assembly (B9) into the opening in the gear (B8), and align the pointer (B9F) with the corresponding position on the top cover (B11). Mount the pointer (B9F) to the gear with the four screws (B9G) and washers (B9H). On the R1 model, tighten the screws (#10-24) to 18 ± 2 inch pounds (2.0 ± 0.2 Nm); on the R2 model, tighten the screws (5/16") to 8 ± 1 foot pounds (11 ± 1 Nm).

Table B: Wedge Identification Numbers for Double-D Valve Shafts

Actuator Size	Dimension Across Shaft Flat, Nominal		Shaft Diameter, Nominal		Wedge Identification Number	
	Inches	mm	Inches	mm	For Two Wedges (B9B) on Shaft Flats	For Two Wedges (B9J) on Shaft Diameter
R1	0.353	9.00	0.434	11.02	6	5
	0.393	10.00	0.496	12.60	5	4
	0.471	12.00	0.621	15.77	4	3
	0.629	16.00	0.746	18.95	3	2
R2	0.629	16.00	0.746	18.95	13	12
	0.944	24.00	1.120	28.45	10	11
	1.259	32.00	1.495	37.97	9	7

Spring-Return Actuator Reassembly

Clean and inspect all parts before reassembly. Refer to Figure 4 for component identification. See “*Lubrication*” section for lubricating requirements.

1. Replace worn parts, especially sealing components such as O-rings and gaskets.
2. Lubricate the following surfaces:
 - The flat side of the rack bearing (B3)
 - Both bearing hubs of the gear (B8)
 - The top cover O-ring (B10) and the groove in the top cover (B11)
 - Both sides of the four wedges in the collet assembly (B9), and the mating four surfaces inside of the gear (B8)
 - The teeth in the rack (B5) and in the gear (B8)
3. Place the rack bearing (B3) on the pin (B4).

Note: A dab of grease on the curved side of the bearing will help hold it in place.
4. Note the witness mark(s) on the teeth near one end of the rack (B5). Assemble the end of the rack opposite the witness marks to the end of the double-acting piston rod (C4) with the rack screw (B7) and lockwasher (B6). Do not tighten the screw until step number 10.
5. With the pneumatic connections facing upwards (towards the top of the actuator), mount the cylinder assembly (C00) and the gasket (B16) to the housing (B1). Using the four studs (B18) on the side of the housing, place the nuts (B20) and lockwashers (B19) on the studs. Tighten the nuts to 26 ± 3 foot pounds (35 ± 4 Nm) if carbon steel, or to 15 ± 2 foot pounds (20 ± 3 Nm) if stainless steel.

Note: The cylinder assembly (C00) is mounted on the left-hand side of the housing for spring-to-close (as viewed when facing the data plate (B24) on the housing) and on the right-hand side for spring-to-open.
6. With the four tapped holes facing upwards, place gear (B8) into the housing bearing (B2), and engage the gear teeth with the rack (B5) according to configuration:
 - **R1 Actuator on a Square valve shaft**

One tooth on the rack is marked with a raised dot that must mesh between two teeth with similar dots on the R1 gear, as shown in Figure 6.
 - **R2 Actuator on a Square valve shaft**

One tooth on the gear is marked with a raised dot that must mesh between two teeth with similar dots on the R2 rack, as shown in Figure 6.
 - **R1 Actuator on a Double-D valve shaft**

One tooth on the rack is marked with a raised dot that must mesh between one of two pair of teeth with similar dots on the R1 gear. The correct pair of teeth to use is shown in Figure 6, as determined by the desired actuator mounting position on the valve. The optional mounting positions are shown on the Valve Installation Drawing.
 - **R2 Actuator on a Double-D valve shaft**

Two non-adjacent teeth on the gear are marked with a raised dot. One of the marked gear teeth must mesh between the two adjacent teeth with similar dots on the R2 rack. The correct gear tooth to use is shown in Figure 6, as determined by the desired actuator mounting position on the valve. The optional mounting positions are shown on the Valve Installation Drawing.

Spring-Return Actuator Reassembly (continued)

7. Place the O-ring (B10) in the groove of the top cover (B11).

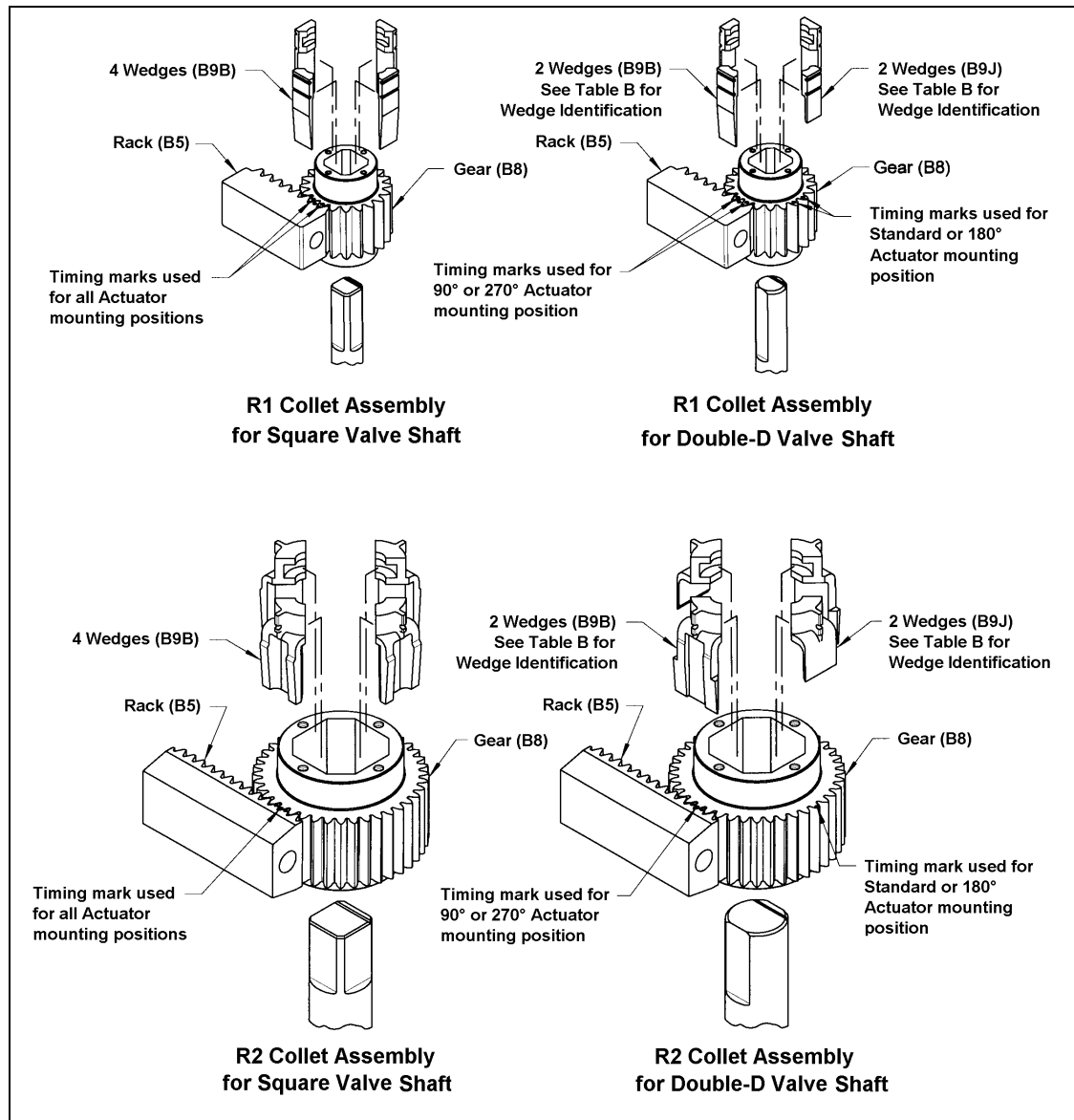

Figure 6—Collet Assembly and Gear Alignment

8. Mount the top cover (B11) and gasket (B13) to the housing (B1) with the four screws (B15) and washers (B14). Tighten the nuts to 26 ± 3 foot pounds (35 ± 4 Nm) if carbon steel, or to 15 ± 2 foot pounds (20 ± 3 Nm) if stainless steel.
9. Place the actuator open position for a spring-to-close actuator or the closed position for a spring-to-open actuator.
10. Tighten the rack screw (B7) as described in step 8.

Spring-Return Actuator Reassembly *(continued)*

11. Turn the jam nut (B22) onto the stop screw (B21), and turn the stop screw into the center hole in the end cover (B17) until the end of the stop screw protrudes about 1/4" (6 mm) through the end cover. Turn the jam nut finger tight.
12. Mount the spring-return cylinder (S00) and the gasket (B16) to the housing studs (B18) with the four nuts (B20) and lockwashers (B19). Tighten the nuts to 26 ± 3 foot pounds (35 ± 4 Nm) if carbon steel, or to 15 ± 2 foot pounds (20 ± 3 Nm) if stainless steel.
13. Turn the adjusting screw (B9A) in the collet assembly (B9) so that the four wedges are about 1/32" (0.8 mm) from the bottom of the pointer (B9F).
14. With the actuator in the open or closed position, place the collet assembly (B9) into the opening in the gear (B8), and align the pointer (B9F) with the corresponding position on the top cover (B11). Mount the pointer (B9F) to the gear with the four screws (B9G) and washers (B9H). On the R1 model, tighten the screws (#10-24) to 18 ± 2 inch pounds (2.0 ± 0.2 Nm); on the R2 model, tighten the screws (5/16") to 8 ± 1 foot pounds (11 ± 1 Nm).

Mounting Actuator

Refer to Figure 2 for component identification.

1. Determine which of the four actuator-to-valve mounting positions is desired, as shown on the Valve Installation Drawing.
2. Match the open or closed position of the valve with the open or closed position of the actuator.
3. Note the position of the word "open" on the top cover (B11).
4. Position the cover on the housing (B1) so that dial hash mark for "open" will be parallel with the pipeline when the valve is installed.

Note: One or more of the steps below may be required, depending upon the mounting position selected, the type of valve shaft, and the positions of the valve, actuator, and actuator cover.

- a. Rotate the valve shaft.
 - b. Stroke the actuator.
 - c. Select a different actuator-to-valve mounting position.
 - d. Remove and re-index the actuator cover: Remove the four cover screws (B15), rotate the cover, and replace the four cover screws (B15) and washers (B14). Tighten the screws to 15 ± 2 foot pounds (20 ± 3 Nm).
 - e. If the valve has a double-D shaft connection, the actuator may be mounted in the standard or 180° position with a given gear-timing configuration, or may be mounted in the 90° or 270° position with an alternative gear-timing configuration. To change to the other configuration, remove the cover screws (B15), the cover (B11), and the gear (B8). Then re-time the gear and replace the cover as described in steps 6 and 7 in the "Double-Acting Actuator Reassembly" section.
5. If the actuator does not include the collet assembly (B9), grease the assembly as described in the "Double-Acting Actuator Reassembly" section and install the assembly as explained in steps 13 and 14 in the same section.

Mounting Actuator *(continued)*

6. Place the gasket (B28) between the actuator and the valve, engage the actuator with the valve shaft in the desired mounting position, and slide the actuator onto the valve shaft.
Note: Certain high-temperature valves include and require a high-temperature gasket. If the valve includes a gasket, use the gasket included with the valve rather than the gasket included with the actuator.
7. Assemble the four actuator mounting screws (B26) with lockwashers (B27) up through the mounting holes in the top of the valve (or the actuator adaptor on the valve), through the gasket (B28), and into the threaded holes in the bottom of the actuator. Tighten the screws finger tight—so that the valve and actuator mounting surfaces are in contact, but are free to slide and self-center during the next step.
8. Tighten the adjusting screw (B9A) in the collet assembly (B9):
 - **For the R1 actuator**, tighten the screw to 16 ± 2 foot pounds (22 ± 3 Nm) if 3/8", or tighten to 22 ± 2 foot pounds (30 ± 3 Nm) if 1/2"
 - **For the R2 actuator**, tighten screw (1/2") to 40 ± 3 foot pounds (54 ± 4 Nm)
9. Tighten the four actuator mounting screws (B26):
 - **For the R1 actuator**, tighten the screws to 26 ± 3 foot pounds (35 ± 4 Nm) if carbon steel, or to 15 ± 2 foot pounds (20 ± 3 Nm) if stainless steel
 - **For the R2 actuator**, tighten the screws to 83 ± 10 foot pounds (113 ± 14 Nm) if carbon steel, or to 38 ± 5 foot pounds (52 ± 7 Nm) if stainless steel.
10. Loosen the adjusting screw (B9A) in the collet assembly (B9).
11. Re-tighten the four actuator mounting screws (B26) as described in step 6 above.
12. Tap the adjusting screw with a rubber mallet so that the gear (B8) bottoms out against the lower housing bearing (B2).
13. Begin to tighten the adjusting screw (B9A); as the adjusting screw becomes snug, repeat step 12. Finish tightening as described in step 8.
14. Tighten the adjusting screw jam nut (B9D):
 - **For the R1 actuator**, tighten the screw to 16 ± 2 foot pounds (22 ± 3 Nm) if 3/8", or tighten to 22 ± 2 foot pounds (30 ± 3 Nm) if 1/2".
 - **For the R2 actuator**, tighten screw (1/2") to 40 ± 3 foot pounds (54 ± 4 Nm).
15. Adjust the open and closed position stops as explained in the “*Open and Closed Position Stops*” section.
16. Operate the actuator and valve three full cycles to demonstrate that the unit operates smoothly in both directions. Do not exceed 100 psi (690 kPa) in cylinder(s).

Changing from Double-Acting to Spring-Return Spring-to-Close

1. Relieve the cylinder pressure, if any, to the actuator.
2. If an actuator accessory will be mounted on the actuator, refer to the Accessory Kit Instructions for cylinder orientation requirements. Certain actuator accessories require the cylinder ports to be rotated 180° to provide piping clearance.
3. Remove the end cover (B17) and gasket (B16) by removing the four nuts (B20) and lockwashers (B19). The end cover, including the stop screw (B21) and jam nut (B22), are not required on a spring-return actuator.
4. Loosen the jam nut (C17) and back out the stop screw (C18) on the double-acting cylinder assembly (C00).
5. Mount the spring-return cylinder assembly (S00) and gasket (B16) to the studs from which the end cover was removed. Use the same four nuts (B20) and lockwashers (B19). Tighten the nuts to 26 ± 3 foot pounds (35 ± 4 Nm) if carbon steel, or to 15 ± 2 foot pounds (20 ± 3 Nm) if stainless steel.
6. If actuator sizing requires a larger (or smaller) double-acting cylinder, replace the double-acting cylinder by following the steps below; however the locations of the two cylinders with respect to the actuator must remain unchanged.
7. Adjust the open and closed position stops as explained in the “*Open and Closed Position Stops*” section.

Changing from Double-Acting to Spring-Return Spring-to-Open

1. If the actuator is on a valve, remove the actuator from the valve as described in the “*Removing Actuator*” section.
2. If an actuator accessory will be mounted on the actuator, refer to the Accessory Kit Instructions for cylinder orientation requirements. Certain actuator accessories require the cylinder ports to be rotated 180° to provide piping clearance.
3. Remove the four pointer screws (B9G), and remove the collet assembly (B9) from the actuator.
4. Remove the four top cover screws (B15), and remove the top cover (B11) and gear (B8).
5. Remove the four cylinder assembly nuts (B20) and lockwashers (B19), and remove the cylinder assembly (C00).
6. Remove the end cover (B17) and gasket (B16) by removing the four nuts (B20) and lockwashers (B22). The end cover, including the stop screw (B21) and jam nut (B22), may be discarded.
7. Loosen the rack screw (B7), but do not remove the rack screw and rack (B5) from the piston rod (C4). Rotate the rack 180° on the rack screw.
8. Ensure that the rack bearing (B3) has stayed in position on the pin (B4). A dab of grease on the curved side of the rack bearing will help to hold it in place if necessary.

Changing from Double-Acting to Spring-Return Spring-to-Open *(continued)*

9. Mount the double-acting cylinder assembly and gasket (B16) to the studs from which the end cover was removed. Place the nuts (B20) and lockwashers (B19) on the studs. Tighten the nuts to 26 ± 3 foot pounds (35 ± 4 Nm) if carbon steel, or to 15 ± 2 foot pounds (20 ± 3 Nm) if stainless steel. Replace the gear (B8), and engage the teeth with the rack (B5) as follows:
 - **R1 actuator on a Square valve shaft**

One tooth on the rack is marked with a raised dot that must mesh between two teeth with similar dots on the R1 gear, as shown in Figure 5.
 - **R2 Actuator on a Square valve shaft**

One tooth on the gear is marked with a raised dot that must mesh between two teeth with similar dots on the R2 rack, as shown in Figure 5.
 - **R1 Actuator on a Double-D valve shaft**

One tooth on the rack is marked with a raised dot that must mesh between one of two pair of teeth with similar dots on the R1 gear. The correct pair of teeth to use is shown in Figure 5, as determined by the desired actuator mounting position on the valve. The optional mounting positions are shown on the Valve Installation Drawing.
 - **R2 Actuator on a Double-D valve shaft**

Two non-adjacent teeth on the gear are marked with a raised dot. One of the marked gear teeth must mesh between the two adjacent teeth with similar dots on the R2 rack. The correct gear tooth to use is shown in Figure 5, as determined by the desired actuator mounting position on the valve. The optional mounting positions are shown on the Valve Installation Drawing.
10. Mount the top cover (B11) and gasket (B13) to the housing (B1) with the four screws (B15) and washers (B14). Tighten the nuts to 26 ± 3 foot pounds (35 ± 4 Nm) if carbon steel, or to 15 ± 2 foot pounds (20 ± 3 Nm) if stainless steel.
11. Place the actuator in the open position (with the rack B5 extended into the actuator) before the next step.
12. Tighten the rack screw (B7). On the R1 actuator, tighten the screw (3/8") to 35 ± 5 foot pounds (47 ± 7 Nm); on the R2 actuator, tighten the screw (1/2") to 89 ± 12 foot pounds (121 ± 16 Nm).
13. Loosen the jam nut (C17) and back out the stop screw (C18) on the double-acting cylinder assembly (C00).
14. Mount the spring-return cylinder assembly (S00) and gasket (B16) to the same studs from which the double-acting cylinder assembly was removed. Place the nuts (B20) and lockwashers (B19) on the studs. Tighten the nuts to 26 ± 3 foot pounds (35 ± 4 Nm) if carbon steel, or to 15 ± 2 foot pounds (20 ± 3 Nm) if stainless steel.
15. Mount the collet assembly (B9) with the four screws (B9G) and washers (B9H). On the R1 actuator, tighten the screws (#10-24) to 18 ± 2 inch pounds (2.0 ± 0.2 Nm); on the R2 actuator, tighten the screws (5/16") to 8 ± 1 foot pounds (11 ± 1 Nm).
16. Replace the actuator on the valve as described in the "Mounting Actuator" section.

Changing from Spring-Return Spring-to-Close to Double-Acting

1. Relieve the cylinder pressure, if any, to the actuator.
2. Remove the four cylinder assembly nuts (B20) and lockwashers (B19), and remove the spring-return cylinder assembly (S00) and gasket (B16).
3. Mount the new end cover (B17) and gasket (B16) to the studs from which the cylinder assembly was removed. Use the same four nuts (B20) and lockwashers (B19). Tighten the nuts to 26 ± 3 foot pounds (35 ± 4 Nm) if carbon steel, or to 15 ± 2 foot pounds (20 ± 3 Nm) if stainless steel.
4. If actuator sizing requires a different sized cylinder, replace the double-acting cylinder by following the steps in the next section.

Changing from Spring-Return Spring-to-Open to Double-Acting

1. If the actuator is on a valve, remove the actuator from the valve as described in the *“Removing Actuator”* section.
2. Disassemble the actuator as described in the *“Actuator Disassembly”* section.
3. Assemble the actuator as described in the *“Double-Acting Actuator Reassembly”* section.
4. Replace the actuator on the valve as described in the *“Mounting Actuator”* section.

Reversing Spring Action

The spring action is not reversible with existing parts.

The spring action of a spring-return actuator may be reversed from spring-to-open to spring-to-close—or vice versa—as described below; however, a new cylinder assembly with the opposite action is required. Cylinder assemblies with opposite action are not interchangeable; thus a spring-to-close cylinder may not be used for spring-to-open, and a spring-to-open cylinder may not be used for spring-to-close.

1. If the actuator is on a valve, remove the actuator from the valve as described in the *“Removing Actuator”* section.
2. Disassemble the actuator as described in the *“Actuator Disassembly”* section.
3. Assemble the actuator as described in the *“Spring-Return Cylinder Reassembly”* section, except: (a) Reverse the locations of the two cylinder assemblies, and (b) Use the appropriate (spring-to-open or spring-to-close) spring assembly.
4. Replace the actuator on the valve as described in the *“Mounting Actuator”* section.

Changing Mounting Position

The actuator may be mounted in any of four positions on the valve.

The mounting position may be changed as follows:

1. Remove the actuator from the valve as described in the *“Removing Actuator”* section.
2. Replace actuator on the valve as described in the *“Mounting Actuator”* section.

Lockable Model

The double-acting and spring-return DeZURIK PowerRac™ R1 and R2 Actuators are each available as a lockable model that allows the actuator to be locked in either the open or closed position. The lockable model is identified by PRL in the catalog characteristic.

As shown in Figure 7, the lockable model has a notched gear (B8) and an enlarged housing (B1) that includes two lock screws (B64) and two jam nuts (B65). A lockout cover assembly (B60) is also included.



CAUTION!

The two lock screws (B64) must be in either the unlocked or the locked position as described in the following sections. The gear (B8) will be damaged if either of the stop screws is placed in an intermediate position between the unlocked and locked positions.

Unlocked Condition

Under normal unlocked running conditions, both of the lock screws are backed out of the housing to allow the gear to rotate freely in either direction. To be fully disengaged, the distance from the housing to the end of each lock screw must be at least 2¼" (57 mm) on the R1 actuator, and at least 3" (76 mm) on the R2 Actuator. To hold the lock screws in position, the jam nuts are tightened to 38 ± 5 foot pounds (52 ± 7 Nm) on the R1 Actuator, and to 77 ± 10 foot pounds (104 ± 14 Nm) on the R2 actuator.

Locked Closed Position

Follow the steps below to change the unit from the unlocked condition to the locked closed position. Refer to Figure 7 for component identification. Before proceeding, the open and closed position stops must be correctly adjusted as described in the Open and Closed Stops section.

1. Operate the actuator to the fully closed (clockwise) position.



WARNING!

Adjust only the left-side lock screw to lock the actuator in the closed position. Adjusting the wrong screw does not lock the actuator, and can result in personal injury or equipment damage.

2. Loosen the jam nut (B65) on the **left** side lock screw (B64), as viewed when facing the top of the heads of the lock screws. Hold the lock screw from turning, and turn the jam nut several turns counterclockwise, to the head of the lock screw.
3. Turn the **left** side lock screw clockwise several turns until resistance is felt from the lock screw contacting the notch in the gear (B8). Tighten the lock screw to 5 to 10 foot pounds (7 to 14 Nm) to assure that the lock screw is contacting the gear.
4. Turn the **left** side jam nut clockwise against the actuator housing. While holding the lock screw from turning, tighten the jam nut to 38 ± 5 foot pounds (52 ± 7) on the R1 Actuator, and to 77 ± 10 foot pounds (104 ± 14 Nm) on the R2 Actuator.
5. Place and lock the lockout cover assembly (B60) on head of the **left** side lock screw.

Lockable Model *(continued)*

Locked Open Position

Follow the steps below to change the unit from the unlocked condition to the locked open position. Refer to Figure 7 for component identification. Before proceeding, the open and closed position stops must be correctly adjusted as described in the Open and Closed Stops section.

1. Operate the actuator to the fully open (counterclockwise) position.



WARNING!

Adjust only the right-side lock screw to lock the actuator in the open position. Adjusting the wrong screw does not lock the actuator, and can result in personal injury or equipment damage.

2. the jam nut (B65) on the **right** side lock screw (B64), as viewed when facing the Loosen top of the heads of the lock screws. Hold the lock screw from turning, and turn the jam nut several turns counterclockwise, to the head of the lock screw.
3. Turn the **right** side lock screw clockwise several turns until resistance is felt from the lock screw contacting the notch in the gear (B8). Tighten the lock screw to 5 to 10 foot pounds to assure that the lock screw is contacting the gear.
4. Turn the **right** side jam nut clockwise against actuator housing. While holding the lock screw from turning, tighten the jam nut to 38 ± 5 foot pounds (52 ± 7 Nm) on the R1 Actuator, and to 77 ± 10 foot pounds (104 ± 14 Nm) on the R2 Actuator.
5. Place & lock the lockout cover assembly (B60) on head of the **right** side lockscrew.

Lockable Model (continued)

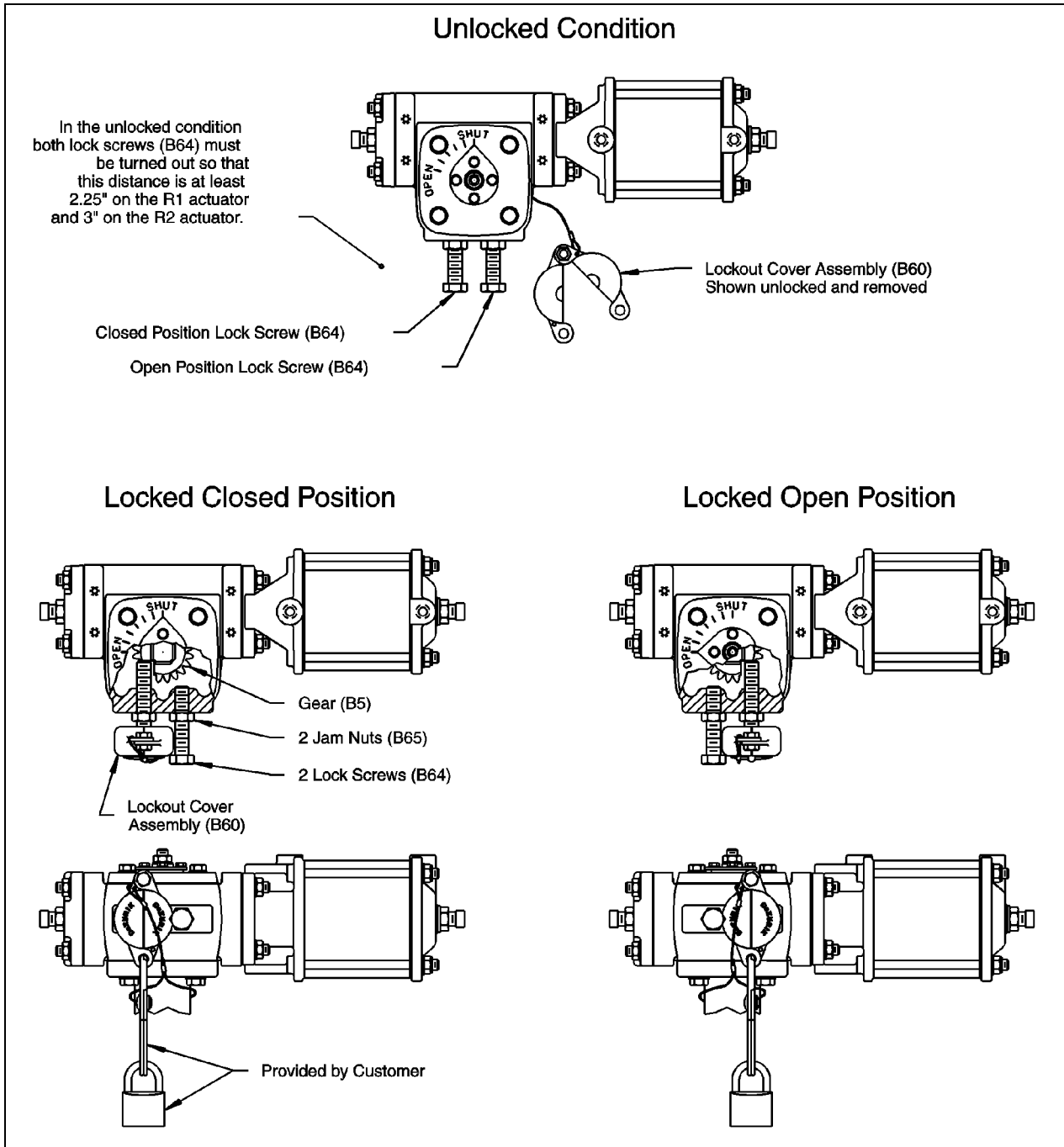

Figure 7 – Lockable Model Component Identification

Troubleshooting

Condition	Possible Cause	Corrective Action
Actuator closes to wrong position.	Closed position stop is set incorrectly.	Adjust closed position stop. See <i>Position Stops</i> section.
Actuator opens to wrong position.	Open position stop is set incorrectly.	Adjust open position stop. See <i>Position Stops</i> section.
Actuator will not fully operate valve.	Cylinder pressure is low.	Increase cylinder pressure. Do not exceed 100 PSI.
	Actuator is not sized correctly.	Use larger actuator.
	Piston seal in cylinder is leaking.	Replace piston seal(s).
	Cylinder has wrong spring assembly.	Use spring assembly with opposite action.
	Obstruction in valve is preventing closure.	Remove obstruction.
	Lockable model is locked.	Place in unlocked condition. See <i>Lockable Model</i> section.
Double-acting actuator rotates wrong direction.	Air connections to cylinder are incorrect.	Reverse air connections to cylinder.
Valve fails in wrong direction with spring-return actuator.	Actuator is assembled incorrectly.	Exchange locations of spring-return and double-acting cylinders.