



**ANSI/AWWA C540  
HYDRAULIC CYLINDER  
FOR T-SERIES ACTUATORS**

# DeZURIK

## ANSI/AWWA C540 Hydraulic Cylinder for T-Series Actuators

---

### Instructions

These instructions provide information about ANSI/AWWA C540 Hydraulic Cylinders. They are for use by personnel who are responsible for installation, operation and maintenance of ANSI/AWWA C540 Hydraulic Cylinders.

### Safety Messages

All safety messages in the instructions are flagged with an exclamation symbol and the word Caution, Warning or Danger. These messages indicate procedures that must be followed exactly to avoid equipment damage, personal injury or death.

Safety label(s) on the product indicate hazards that can cause equipment damage, personal injury or death. If a safety label becomes difficult to see or read, or if a label has been removed, please contact DeZURIK for replacement label(s).



#### **WARNING!**

**Personnel involved in the installation or maintenance of valves should be constantly alert to potential emission of pipeline material and take appropriate safety precautions. Always wear suitable protection when dealing with hazardous pipeline materials. Handle valves which have been removed from service with the assumption of pipeline material within the valve.**

---

### Inspection

Your ANSI/AWWA C540 Hydraulic Cylinder has been packaged to provide protection during shipment, however, it can be damaged in transport. Carefully inspect the unit for damage upon arrival and file a claim with the carrier if damage is apparent.

### Parts

Recommended spare parts are listed on the assembly drawing. These parts should be stocked to minimize downtime.

Order parts from your local DeZURIK sales representative, or directly from DeZURIK. When ordering parts, please include the 7-digit part number and 4-digit revision number (example: **9999999R000**) located on the data plate attached to the valve assembly. Also include the part name, the assembly drawing number, the balloon number and the quantity stated on the assembly drawing.

### DeZURIK Service

DeZURIK service personnel are available to install, maintain and repair all DeZURIK products. DeZURIK also offers customized training programs and consultation services.

For more information, contact your local DeZURIK sales representative or visit our website at [www.dezurik.com](http://www.dezurik.com).

**Table of Contents**

Description	-----	2
Supply	-----	2
Lubrication	-----	2
Tools Required	-----	2
Closed Position Adjustment	-----	2
Disassembly	-----	2
Reassembly	-----	3

# DeZURIK

## ANSI/AWWA C540 Hydraulic Cylinder for T-Series Actuators

---

**Description** The ANSI/AWWA C540 Water Hydraulic Double-Acting Cylinder, for use with T-Series Actuators, is intended for water hydraulic service. This cylinder can be used with pumpcheck accessories.

**Supply** The maximum cylinder supply pressure is 150 psi.

**Lubrication** The cylinder does not require a lubricant in the actuating medium. If the cylinder is disassembled, lubricate all seals, O-rings, the cylinder wall and piston seal using one of these lubricants.

- Dow Corning Molykote No. 44 (**recommended**)
- Shell Retinax AM (alternate)
- Shell Lithall MDS (alternate)

**Tools Required** The cylinder is assembled with SAE fasteners. Tools required for adjustment and disassembly include a set of combination wrenches, a flat-tipped screwdriver and a small hammer.



**WARNING!**

**This cylinder is a pressure vessel. Supply pressure must be disconnected from the cylinder and the cylinder completely relieved of pressure before disassembling the cylinder. Failure to release pressure may result in personal injury and/or damage to other equipment.**

---

**Closed Position Adjustment**

The set screw in the end of the cylinder is used to limit the cylinder stroke.

1. Pressurize the cylinder port nearest the actuator housing, closing the valve.
2. Relieve cylinder pressure. See Valve Instructions to determine closed position.
3. Loosen the lock nut and turn the set screw in the end of the cylinder in or out until the valve is in the correct closed position.
4. Reapply cylinder pressure to the port nearest the actuator housing, closing the valve, to ensure that stop is correctly set.
5. Lock the set screw in place with the nut. Be sure the thread seal is in place.

**Disassembly**

Follow the steps below to disassemble the cylinder.

1. Shut off the water pressure supply to the cylinder.
2. Relieve pressure in the cylinder.
3. Disconnect the tubing from the cylinder.
4. If the actuator is powered, disconnect and lock out the pneumatic, hydraulic, or electrical power to prevent accidental operation of the actuator.



**WARNING!**

**Moving parts from accidental operation of power actuator can cause personal injury or equipment damage. Disconnect and lock out power to actuator before servicing.**

---

**Disassembly**  
*(Continued)*

5. Remove nuts and washers from the tie rods.
6. Remove cylinder cap.
7. Remove O-ring from cylinder cap.
8. Pull cylinder tube off piston, rotating cylinder while pulling.
9. Remove tie rods from cylinder head.
10. Remove nut that holds piston on piston rod, then slide piston off.
11. Remove piston seal and O-ring from piston.
12. Remove the four screws that fasten the cylinder head to the actuator housing, then slide cylinder head off the piston rod.
13. Remove rod seal and O-ring from cylinder head.

**Reassembly**

1. Lubricate the rod seals, then push them into place in the cylinder head as shown in Figure 1. Be sure the grooves in the U-cups face the piston end of the cylinder head.

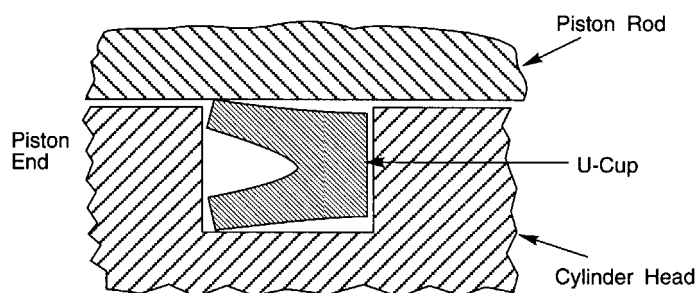

**Figure 1 –Piston Rod U-Cup Seal Placement**

2. Be sure the vent in the cylinder head is clear.
3. Carefully slide cylinder head over piston rod until head contacts actuator housing.
4. Used four screws to fasten the cylinder head to the housing.

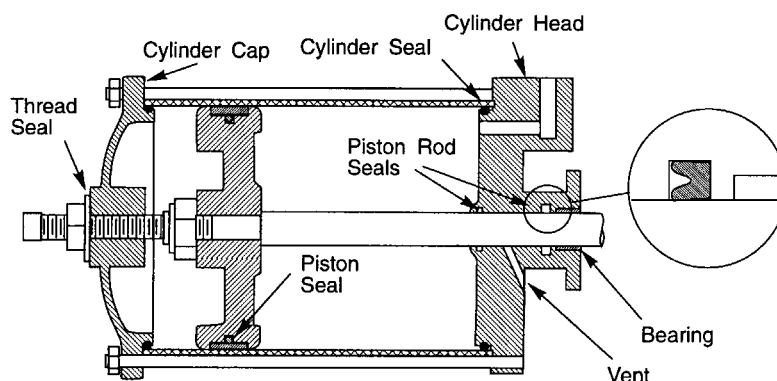

**Figure 2 –Cylinder Parts Location**

# DeZURIK

## ANSI/AWWA C540 Hydraulic Cylinder for T-Series Actuators

---

### Reassembly (Continued)

5. Lubricate the small O-ring, then slide it into the counterbore in the piston.
6. Slide piston onto piston rod so O-ring in piston faces the cylinder head.
7. Install nut that holds piston on piston rod, then tighten nut to 45 foot pounds.
8. Lubricate the medium sized O-ring, then stretch it onto the piston until it fits into the groove.
9. Lubricate piston seal, then slide it onto the piston without stretching it any more than necessary. The seal goes into the groove over the O-ring.
10. Lubricate, then stretch one of the large O-rings into the groove in the cylinder head.
11. On 6-inch and larger cylinders, remove one or two of the tie rods.
12. Lubricate the inside of the cylinder tube, then slide it over the piston. Start with the tube at a 45-degree angle to the piston and rotate the tube onto the piston. See Figure 3.
13. Be sure vent in cylinder head is clear.
14. Thread the tie rods into the cylinder head.
15. Lubricate, then stretch the other large O-ring into the groove in the cylinder cap.
16. Slide the cylinder cap over the tie rods and push the cap in until its O-ring slides into the cylinder tube.
17. Place washers and nuts on the tie rods and tighten the nuts to the torque shown in Table A.

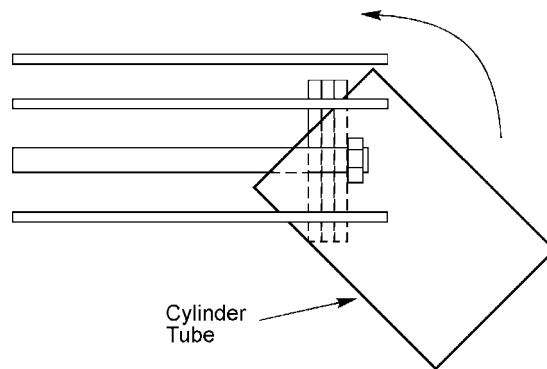

**Figure 3—Installing Cylinder Tube**

**Reassembly.**  
*(Continued)*

**Table A: Cylinder Rod Nut Torques**

Cylinder Size	Torque		
	(ft lbs)	(cm/kg)	(Nm)
3" & 4"	12	175	16
6" & 8"	16	225	22
10" & 12"	20	275	27

18. Check the open and closed position stops and readjust them if necessary. See the ADJUSTMENT section of these instructions and the OPEN POSITION ADJUSTMENT section of the actuator instructions.
19. If the actuator is powered, reconnect power to the actuator.