

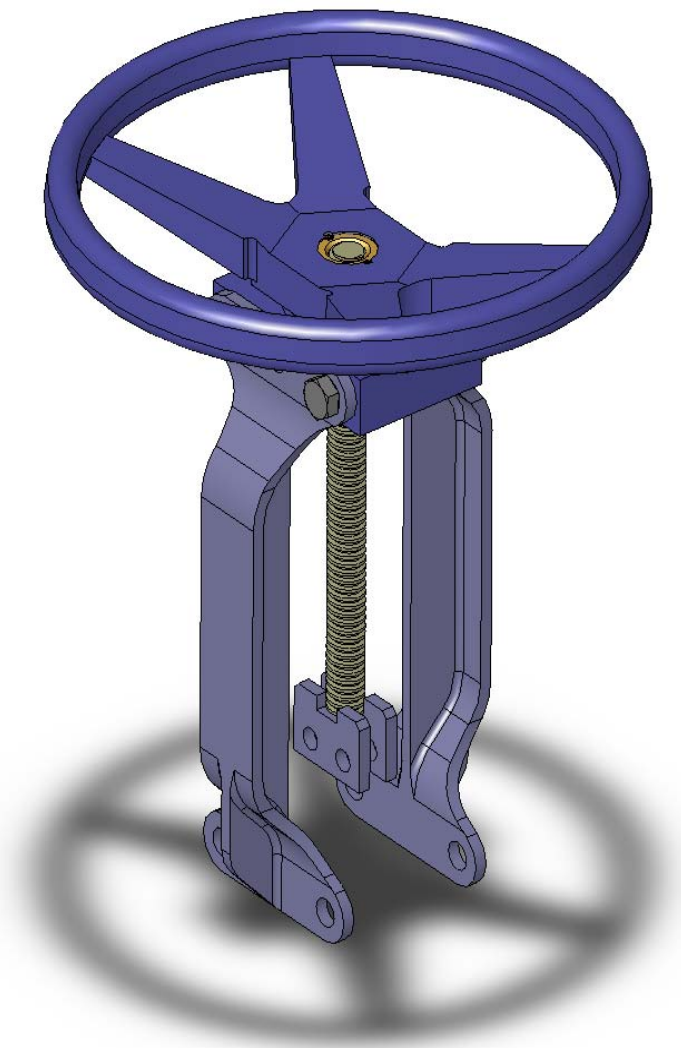

MANUAL ACTUATORS FOR GKU KNIFE GATE VALVES



Instruction **D10450**
March 2009

DeZURIK

Manual Actuators for GKU Knife Gate Valves

Instructions

These instructions provide information about manual actuators. They are for use by personnel who are responsible for installation, operation and maintenance of manual actuators.

Safety Messages

All safety messages in the instructions are flagged with an exclamation symbol and the word Caution, Warning or Danger. These messages indicate procedures that must be followed exactly to avoid equipment damage, personal injury or death.

Safety label(s) on the product indicate hazards that can cause equipment damage, personal injury or death. If a safety label becomes difficult to see or read, or if a label has been removed, please contact DeZURIK for replacement label(s).



WARNING!

Personnel involved in the installation or maintenance of valves should be constantly alert to potential emission of pipeline material and take appropriate safety precautions. Always wear suitable protection when dealing with hazardous pipeline materials. Handle valves, which have been removed from service with suitable protection for any potential pipeline material in the valve.

Inspection

Your manual actuator has been packaged to provide protection during shipment, however, it can be damaged in transport. Carefully inspect the unit for damage upon arrival and file a claim with the carrier if damage is apparent.

Parts

Recommended spare parts are listed on the assembly drawing. These parts should be stocked to minimize downtime.

Order parts from your local DeZURIK sales representative, or directly from DeZURIK. When ordering parts, please include the 7-digit part number and 4-digit revision number (example: **9999999R000**) located on the data plate attached to the valve assembly. Also include the part name, the assembly drawing number, the balloon number and the quantity stated on the assembly drawing.

DeZURIK Service

DeZURIK service personnel are available to install, maintain and repair all DeZURIK products. DeZURIK also offers customized training programs and consultation services.

For more information, contact your local DeZURIK sales representative or visit our website at www.dezurik.com.

Table of Contents

Lubrication -----	4
Operation -----	4
Actuator Disassembly (Handwheel) -----	4
Actuator Re-assembly (Handwheel) -----	6
Actuator Disassembly (Chainwheel) -----	7
Actuator Re-assembly (Chainwheel)-----	9
Actuator Disassembly (Extended Non-Rising Stem) -----	10
Actuator Re-assembly (Extended Non-Rising Stem) -----	12
Actuator Disassembly (Bevel Gear) -----	10
Actuator Re-assembly (Bevel Gear) -----	12

DeZURIK

Manual Actuators for GKU Knife Gate Valves

Lubrication

Lubricate the fitting near the top of the yoke monthly with a lithium-based grease.

Operation

Rotate the handwheel or chainwheel clockwise to close the valve.

Note: There is an arrow cast on the wheel to indicate direction of rotation.

Actuator Disassembly (Handwheel)

See Figure 1 for Parts Identification.

1. Discontinue flow and relieve pipeline pressure. Close the valve.



WARNING!

Pipeline pressure can cause personal injury or equipment damage. Relieve pipeline pressure before disassembling actuator.

2. Remove the 2 set screws (B14) holding the handwheel (B1) to the yoke sleeve (B5).
3. Unscrew the handwheel (B1) from the yoke sleeve (B5).
4. Lift off the thrust bearing (B4).
5. Remove the 2 nuts (B16) and screws (B15) holding the yokes (B7) to the yoke block (B2) and remove the yoke block.
6. Remove the screws (B10) holding the yokes (B7) to the body and remove the yokes.
7. Un-thread the yoke sleeve (B5) from the stem (B6).
8. Remove the 2 screws (B8) and nuts (B9) holding the stem (B6) to the gate and remove the stem.

DeZURIK
Manual Actuators for GKU Knife Gate Valves

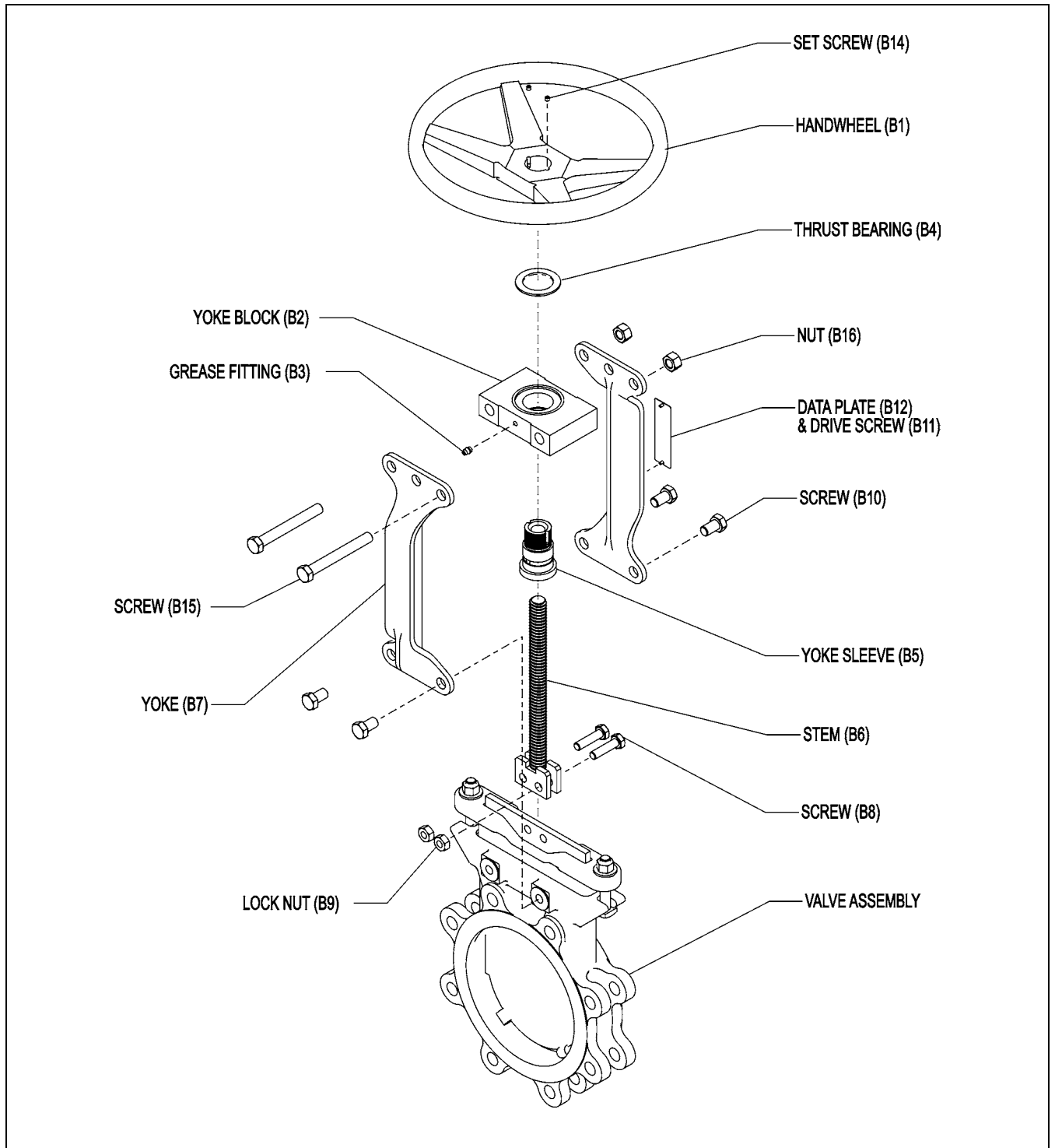

Figure 1—Handwheel Actuator Assembly

DeZURIK

Manual Actuators for GKU Knife Gate Valves

Actuator Re-assembly (Handwheel)

See Figure 1 for Parts Identification.

1. Close the valve.
2. Fasten the stem (B6) to the gate with 2 screws (B8) and nuts (B9).
3. Thread the yoke sleeve (B5) onto the stem (B6).
4. Fasten the yokes (B7) to the valve body but leave the screws (B10) slightly loose for now.
5. Install the yoke block (B2) onto the yoke sleeve (B5) making sure the raised diameter on the yoke block is outward toward the handwheel (B1).
6. Turn the yoke sleeve (B5) to align the holes in the yoke block (B2) with the holes in the yokes (B7), then install the 2 screws (B15) and nuts (B16) leaving them slightly loose for now.
7. Lubricate the thrust bearing (B4), then slide it onto the yoke sleeve (B5) and onto the top of the yoke block (B2).
8. Thread the handwheel (B1) onto the yoke sleeve (B5) until it is tight and the 2 set screw holes line up with the holes in the yoke sleeve.

Note: It will be necessary to hold the yoke sleeve (B5) from turning when tightening the handwheel (B1).

9. Install the 2 set screws (B14) to lock the handwheel (B1) in place.
10. Begin tightening the 4 screws (B10) holding the yokes (B7) to the valve body and the 2 screws (B15) and nuts (B16) holding the yokes (B7) to the yoke block (B2). Operate the valve full open and closed a few times and check for yoke mis-alignment or binding of the mechanism. Loosen and re-tighten the screws to correct any mis-alignment. All fasteners must be tight and the valve must operate without binding.
11. Pipeline pressure and flow can now be re-started. Check valve for packing leaks and adjust packing gland screws as needed to stop leakage. (See Valve Instruction manual).

Actuator Disassembly (Chainwheel)

See Figure 2 for Parts Identification.

1. Discontinue flow and relieve pipeline pressure. Close the valve.



WARNING!

Pipeline pressure can cause personal injury or equipment damage.

Relieve pipeline pressure before disassembling actuator.

2. Remove the 3 screws (B20) holding the chain guide retainer (B19) to the chainwheel (B17) and remove the retainer being careful to hold the chain guide from falling off.
3. Remove the chain guide (B18) from the chainwheel (B17).
4. Remove the 2 set screws (B14) holding the chainwheel (B17) to the yoke sleeve (B5).
5. Unscrew the chainwheel (B17) from the yoke sleeve (B5).
6. Lift off the thrust bearing (B4).
7. Remove the 2 nuts (B16) and screws (B15) holding the yokes (B7) to the yoke block (B2) and remove the yoke block.
8. Remove the screws (B10) holding the yokes (B7) to the body and remove the yokes.
9. Un-thread the yoke sleeve (B5) from the stem (B6).
10. Remove the 2 screws (B8) and nuts (B9) holding the stem (B6) to the gate and remove the stem.

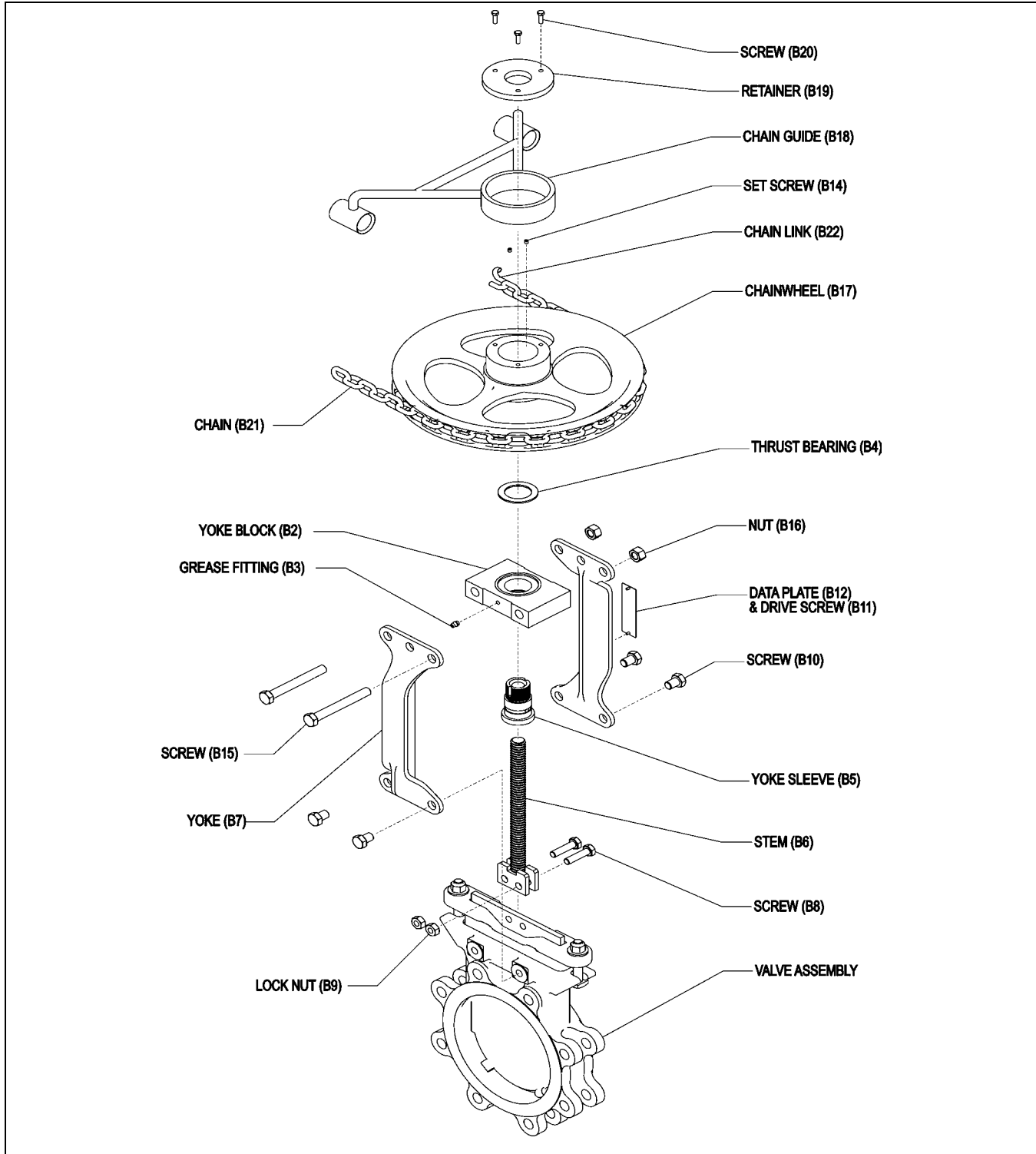

Figure 2—Chainwheel Actuator Assembly

Actuator Re-assembly (Chainwheel)

See Figure 2 for Parts Identification.

1. Close the valve.
2. Fasten the stem (B6) to the gate with 2 screws (B8) and nuts (B9).
3. Thread the yoke sleeve (B5) onto the stem (B6).
4. Fasten the yokes (B7) to the valve body but leave the screws (B10) slightly loose for now.
5. Install the yoke block (B2) onto the yoke sleeve (B5) making sure the raised diameter on the yoke block is outward toward the chainwheel(B17).
6. Turn the yoke sleeve (B5) to align the holes in the yoke block (B2) with the holes in the yokes (B7), then install the 2 screws (B15) and nuts (B16) leaving them slightly loose for now.
7. Lubricate the thrust bearing (B4), then slide it onto the yoke sleeve (B5) and onto the top of the yoke block (B2).
8. Thread the chainwheel (B17) onto the yoke sleeve (B5) until it is tight and the 2 set screw holes line up with the holes in the yoke sleeve.
Note: It will be necessary to hold the yoke sleeve (B5) from turning when tightening the chainwheel (B1).
9. Install the 2 set screws (B14) to lock the chainwheel (B17) in place.
10. Slide the chain guide (B18) onto the chainwheel hub, then fasten the retainer (B19) to the chainwheel (B17) with the 3 screws (B20).
Note: For safety, apply Loctite #222 Removable Threadlocker or equal to the 3 retainer screws (B20) as they are installed to prevent them from loosening during operation.
11. Begin tightening the 4 screws (B10) holding the yokes (B7) to the valve body and the 2 screws (B15) and nuts (B16) holding the yokes (B7) to the yoke block (B2). Operate the valve full open and closed a few times and check for yoke mis-alignment or binding of the mechanism. Loosen and re-tighten the screws to correct any mis-alignment. All fasteners must be tight and the valve must operate without binding.
12. Pipeline pressure and flow can now be re-started. Check valve for packing leaks and adjust packing gland screws as needed to stop leakage. (See Valve Instruction manual).

Actuator Disassembly (Extended Non-Rising Stem)

See Figure 3 for Parts Identification.

1. Discontinue flow and relieve pipeline pressure. Close the valve.



WARNING!

Pipeline pressure can cause personal injury or equipment damage.

Relieve pipeline pressure before disassembling actuator.

2. Remove the pin (B11) holding the handwheel (B1) or wrenching square (B10) to the extension shaft (B12).
3. Remove the 2 pins (B13) holding the extension shaft (B12) to the extension (B14).
4. Slide the extension shaft (B12) out of any bearing supports.
5. Remove the 2 pins (B2) holding the extension (B14) to the yoke sleeve (B5).
6. Lift the extension (B14) from the yoke sleeve (B5).
7. Lift off the thrust bearing (B4).
8. Remove the 2 nuts (B16) and screws (B15) holding the yokes (B7) to the yoke block (B2) and remove the yoke block.
9. Remove the screws (B10) holding the yokes (B7) to the body and remove the yokes.
10. Un-thread the yoke sleeve (B5) from the stem (B6).
11. Remove the 2 screws (B8) and nuts (B9) holding the stem (B6) to the gate and remove the stem.

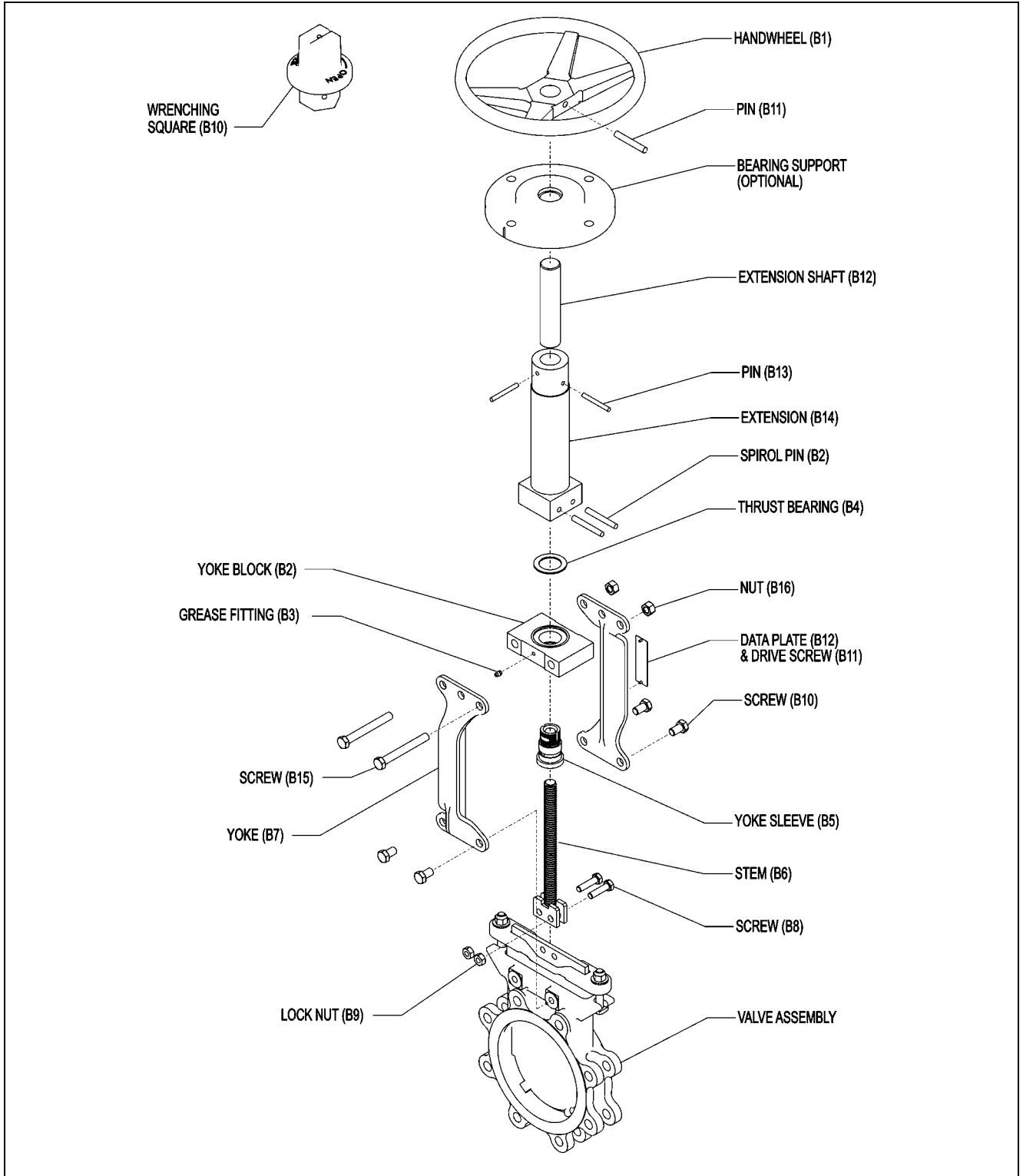



Figure 3—Extended Non-Rising Stem Actuator Assembly

Actuator Re-assembly (Extended Non-Rising Stem)

See Figure 3 for Parts Identification.

1. Close the valve.
2. Fasten the stem (B6) to the gate with 2 screws (B8) and nuts (B9).
3. Thread the yoke sleeve (B5) onto the stem (B6).
4. Fasten the yokes (B7) to the valve body but leave the screws (B10) slightly loose for now.
5. Install the yoke block (B2) onto the yoke sleeve (B5) making sure the raised diameter on the yoke block is outward toward the extension (B14).
6. Turn the yoke sleeve (B5) to align the holes in the yoke block (B2) with the holes in the yokes (B7), then install the 2 screws (B15) and nuts (B16) leaving them slightly loose for now.
7. Lubricate the thrust bearing (B4), then slide it onto the yoke sleeve (B5) and onto the top of the yoke block (B2).
8. Set the extension (B14) onto the yoke sleeve (B5), then turn it until the 2 side-by-side holes line up with the pin ways in the yoke sleeve.
9. Insert a 5/16" diameter bolt into one of the holes.

Note: This will prevent mis-alignment. If the holes are not aligned, the pin ways in the yoke sleeve (B5) could be damaged by the Spirol pins (B2).

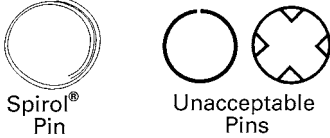
 <p>WARNING!</p> <p>This actuator has been designed to use only heavy-duty Spirol brand pins. The use of any other type of pin will result in actuator failure. See Figure 4.</p>	 <p>Figure 4—Pin Designs</p>
---	---

10. Drive a Spirol pin (B2) into the remaining hole in the extension (B14) until the end of the pin is flush with the outer surface of the extension.
11. Remove the 5/16" bolt installed in Step 10, then drive a Spirol pin (B2) into the hole.
12. Begin tightening the 4 screws (B10) holding the yokes (B7) to the valve body and the 2 screws (B15) and nuts (B16) holding the yokes (B7) to the yoke block (B2). Operate the valve full open and closed a few times and check for yoke mis-alignment or binding of the mechanism. Loosen and re-tighten the screws to correct any mis-alignment. All fasteners must be tight and the valve must operate without binding.
13. Slide the extension shaft (B12) into the top of the extension (B14) and install the 2 pins (B13).
14. Slide the handwheel (B21) or wrenching square (B10) onto the extension shaft (B12) and install the pin (B11).
15. Pipeline pressure and flow can now be re-started. Check valve for packing leaks and adjust packing gland screws as needed to stop leakage. (See Valve Instruction manual).

Actuator Disassembly (Bevel Gear)

See Figure 5 for Parts Identification.

1. Discontinue flow and relieve pipeline pressure. Close the valve.



WARNING!

Pipeline pressure can cause personal injury or equipment damage. Relieve pipeline pressure before disassembling actuator.

2. Remove the 4 screws (B13) holding the actuator (B5) to the collar (B2).
3. Unscrew the actuator (B5) from the stem (B6).
4. Lift off the thrust bearing (B4).
5. Remove the 2 nuts (B16) and screws (B15) holding the yokes (B7) to the yoke block (B2) and remove the yoke block.
6. Remove the screws (B10) holding the yokes (B7) to the body and remove the yokes.
7. Un-thread the yoke sleeve (B5) from the stem (B6).
8. Remove the 2 screws (B8) and nuts (B9) holding the stem (B6) to the gate and remove the stem.