

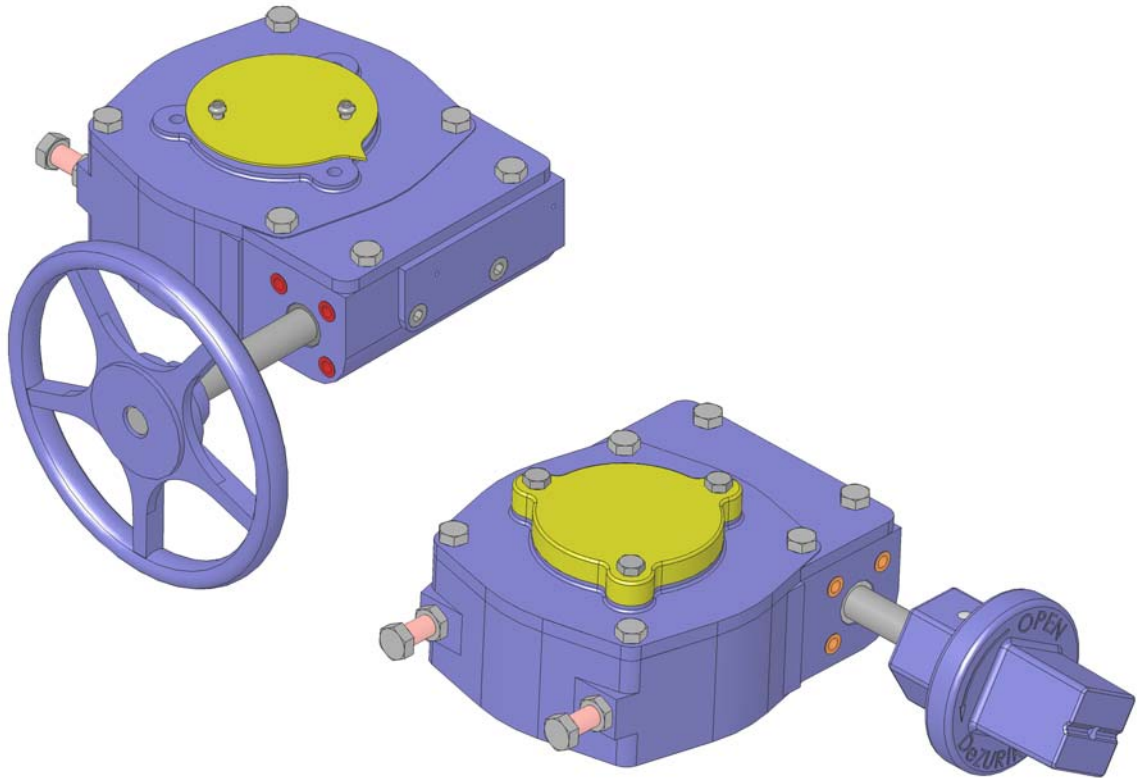

# **G-SERIES MANUAL ACTUATOR USED ON BAW BUTTERFLY VALVES**



Instruction **D10463**  
March 2009

# DeZURIK

## G-Series Manual Actuator used on BAW Butterfly Valves

---

### Instructions

These instructions provide information about G-Series Manual Actuators. They are for use by personnel who are responsible for installation, operation and maintenance of G-Series Manual Actuators.

### Safety Messages

All safety messages in the instructions are flagged with an exclamation symbol and the word Caution, Warning or Danger. These messages indicate procedures that must be followed exactly to avoid equipment damage, personal injury or death.

Safety label(s) on the product indicate hazards that can cause equipment damage, personal injury or death. If a safety label becomes difficult to see or read, or if a label has been removed, please contact DeZURIK for replacement label(s).



#### **WARNING!**

**Personnel involved in the installation or maintenance of valves should be constantly alert to potential emission of pipeline material and take appropriate safety precautions. Always wear suitable protection when dealing with hazardous pipeline materials. Handle valves, which have been removed from service with suitable protection for any potential pipeline material in the valve.**

---

### Inspection

Your G-Series Manual Actuator has been packaged to provide protection during shipment; however, it can be damaged in transport. Carefully inspect the unit for damage upon arrival and file a claim with the carrier if damage is apparent.

### Parts

Recommended spare parts are listed on the assembly drawing. These parts should be stocked to minimize downtime.

Order parts from your local DeZURIK sales representative, or directly from DeZURIK. When ordering parts, please include the 7-digit part number and 4-digit revision number (example: **9999999R000**) located on the data plate attached to the valve assembly. Also include the part name, the assembly drawing number, the balloon number and the quantity stated on the assembly drawing.

### DeZURIK Service

DeZURIK service personnel are available to install, maintain and repair all DeZURIK products. DeZURIK also offers customized training programs and consultation services.

For more information, contact your local DeZURIK sales representative or visit our website at [www.dezurik.com](http://www.dezurik.com).

**Table of Contents**

Description .....	4
Operation .....	4
Tools Required .....	4
Lubrication .....	4
Adjusting Position Stops	
<i>Adjusting the Open Position Stop</i> .....	6
<i>Adjusting the Closed Position Stop</i> .....	6
Removing Actuator .....	8
Installing Actuator .....	9
Actuator Disassembly and Assembly	
<i>Disassembling Actuator</i> .....	10
<i>Reassembling Actuator</i> .....	11
Changing Mounting Positions .....	12
Troubleshooting .....	13

# DeZURIK

## G-Series Manual Actuator used on BAW Butterfly Valves

---

### Description

The G-Series Manual Actuator is designed to operate a BAW Butterfly valve. External adjustable stops limit actuator stroke for both the open and closed valve positions. This actuator is available in two sizes: Size 6A and Size 12A. See Figure 1 to identify which unit you have.

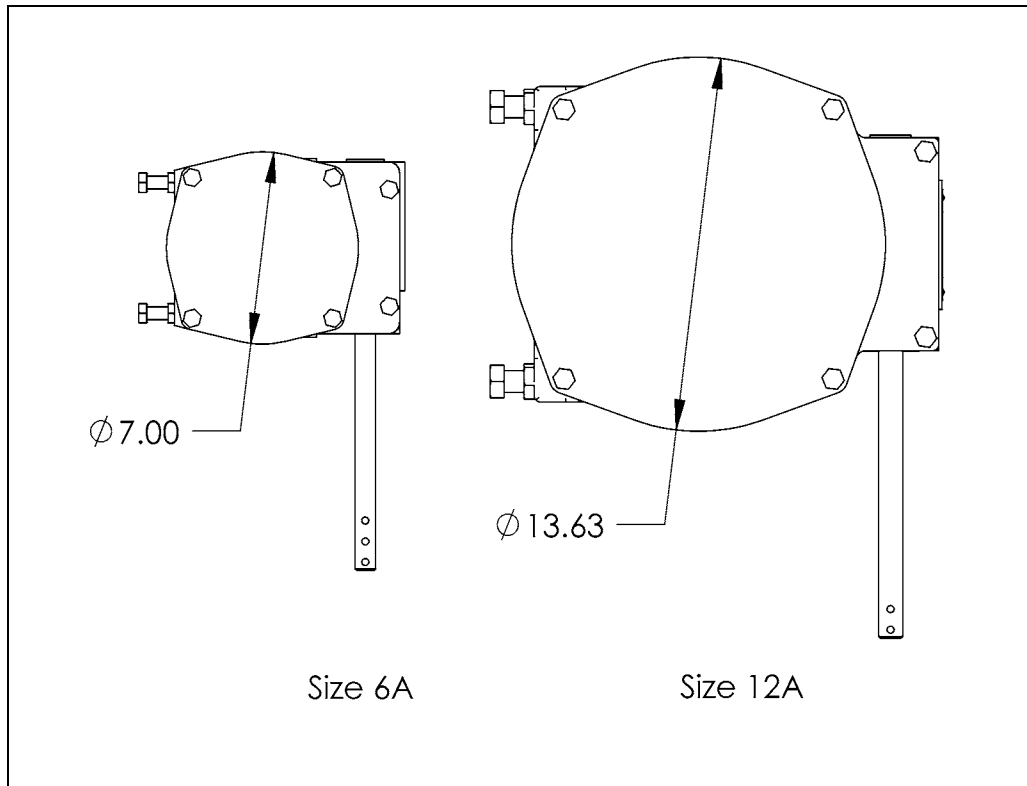

Figure 1 - Actuator Identification

### Operation

Rotating the operator (handwheel or 2" wrenching square) clockwise closes the valve. Counterclockwise rotation of the operator opens the valve. To actuate the valve from full open to full closed (or vice-versa), the Size 6A requires 13 revolutions and the Size 12A requires 19 revolutions of the operator.

### Tools Required

This actuator is assembled using metric fasteners. To service this unit, you should have a full set of combination or ratchet wrenches, Allen wrenches, flat tipped screwdrivers, a 1/4" pin punch and a dead blow hammer.

### Lubrication

The G-Series manual Actuator has been lubricated at the factory and requires no routine maintenance lubrication. If the actuator requires disassembly, see the ACTUATOR DISASSEMBLY AND ASSEMBLY section in this instruction for disassembly, lubrication and assembly procedures.

**Parts Identification**

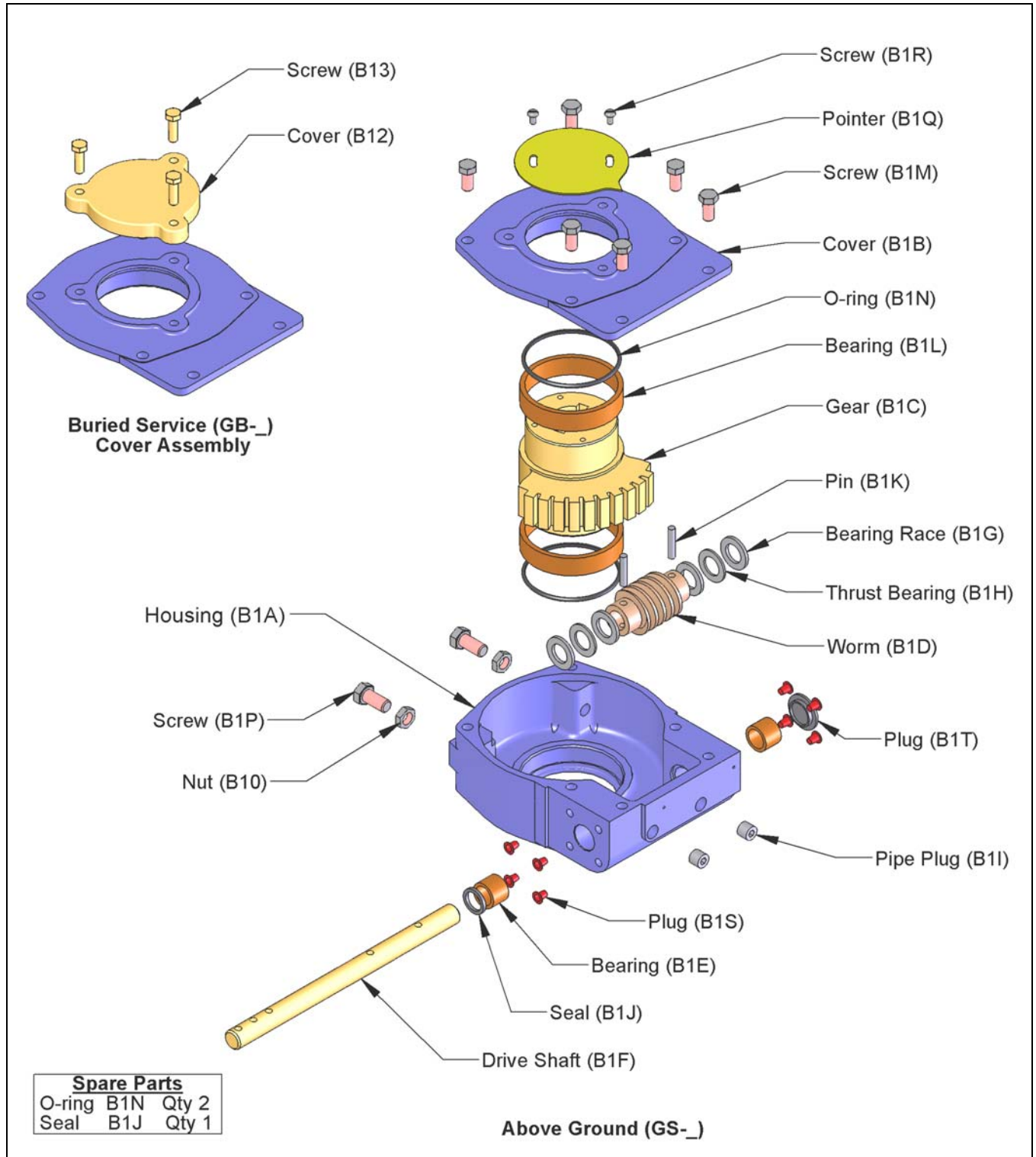

**Figure 2— Actuator Parts Identification**

### Adjusting Position Stops

The open and closed position stops prevent the valve disc from rotating beyond the optimum open and shutoff positions.

If the actuator is factory-mounted on the valve, the stops are preset, and do not require further adjustment. If the actuator is not factory mounted on the valve, or if the actuator has been removed, the stops will require adjustment as described below; also refer to the Valve Instructions for specific closed-position requirements for the valve.

***To adjust the closed position stop:*** (see Figure 4 for stop identification)



**WARNING!**

**Adjusting stops with flow in the pipeline can allow the valve to close causing personal injury and damaging the flow system.**

**Shut down the flow and relieve pipeline pressure before making stop adjustments.**

---

1. Discontinue flow and relieve pipeline pressure.
2. Loosen the nut on the closed position screw, and back out the screw about two turns.
3. Close the valve.
4. Turn the closed position screw clockwise until resistance is felt from the screw contacting the gear (B1C).
5. Prevent the screw from turning and tighten the nut against housing (B1A).
6. Pipeline flow may now be restored.

***To adjust the open position stop:*** (see Figure 4 for stop identification)



**WARNING!**

**Adjusting stops with flow in the pipeline can allow the valve to close causing personal injury and damaging the flow system.**

**Shut down the flow and relieve pipeline pressure before making stop adjustments.**

---

1. Discontinue flow and relieve pipeline pressure.
2. To visually determine when the valve is in the open position:  
**Above Ground Service (GS\_) actuator** - Remove the screws (B1R) and pointer (B1Q).  
**Buried Service (GB\_) actuator** - Remove the screws (B13) and cover (B12).
3. Loosen the nut on the open position screw, and back out the screw about two turns.

**G-Series Manual Actuator used on BAW Butterfly Valves**

**Adjusting Position Stops (Continued)**

4. Turn the handwheel or 2" wrenching square operator so the drive key/plug alignment is parallel to the valve flanges. See Figure 3 for valve open position.

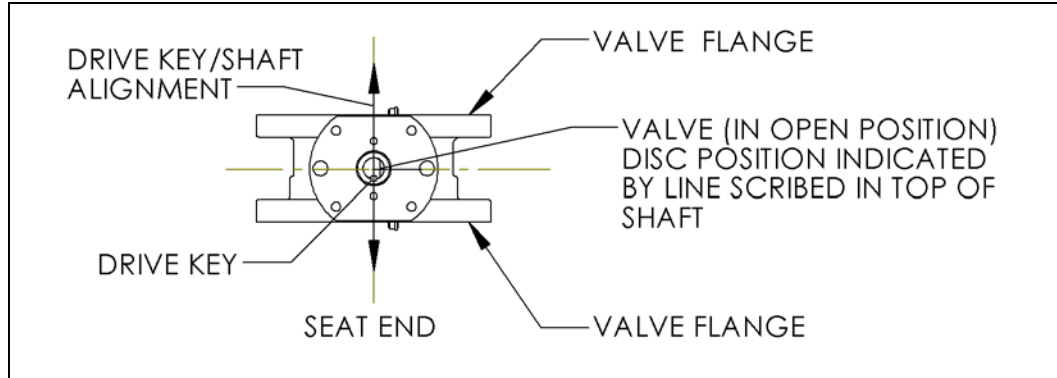
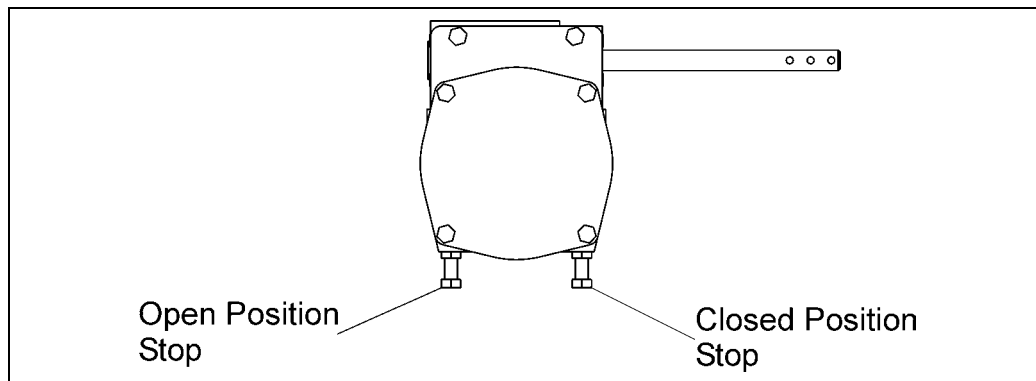

**Figure 3 – Valve Open Position**

5. Turn the open position screw clockwise until resistance is felt from the screw contacting the gear (B1C).
6. Prevent the screw from turning, and tighten the nut against housing (B1A).
7. **Above Ground Service (GS\_) actuator:** Replace the pointer (B1Q) so it is pointing at the OPEN mark on the cover (B1B) and tighten screws (B1R).

**Buried Service (GB\_) actuator:** Remove old sealant from cover (B12) and cover (B1B) mating mounting surfaces. Apply a bead of silicone sealant DOW RTV-732 (1055515) or similar to the cover (B12) and cover (B1B) mating surfaces. Fasten the cover (B12) to cover (B1B) with screws (B13).

8. Pipeline flow may now be restored.



**Figure 4 – Open and Closed Position Stop Identification**

### Removing Actuator

Refer to Figure 5 for connecting parts identification.

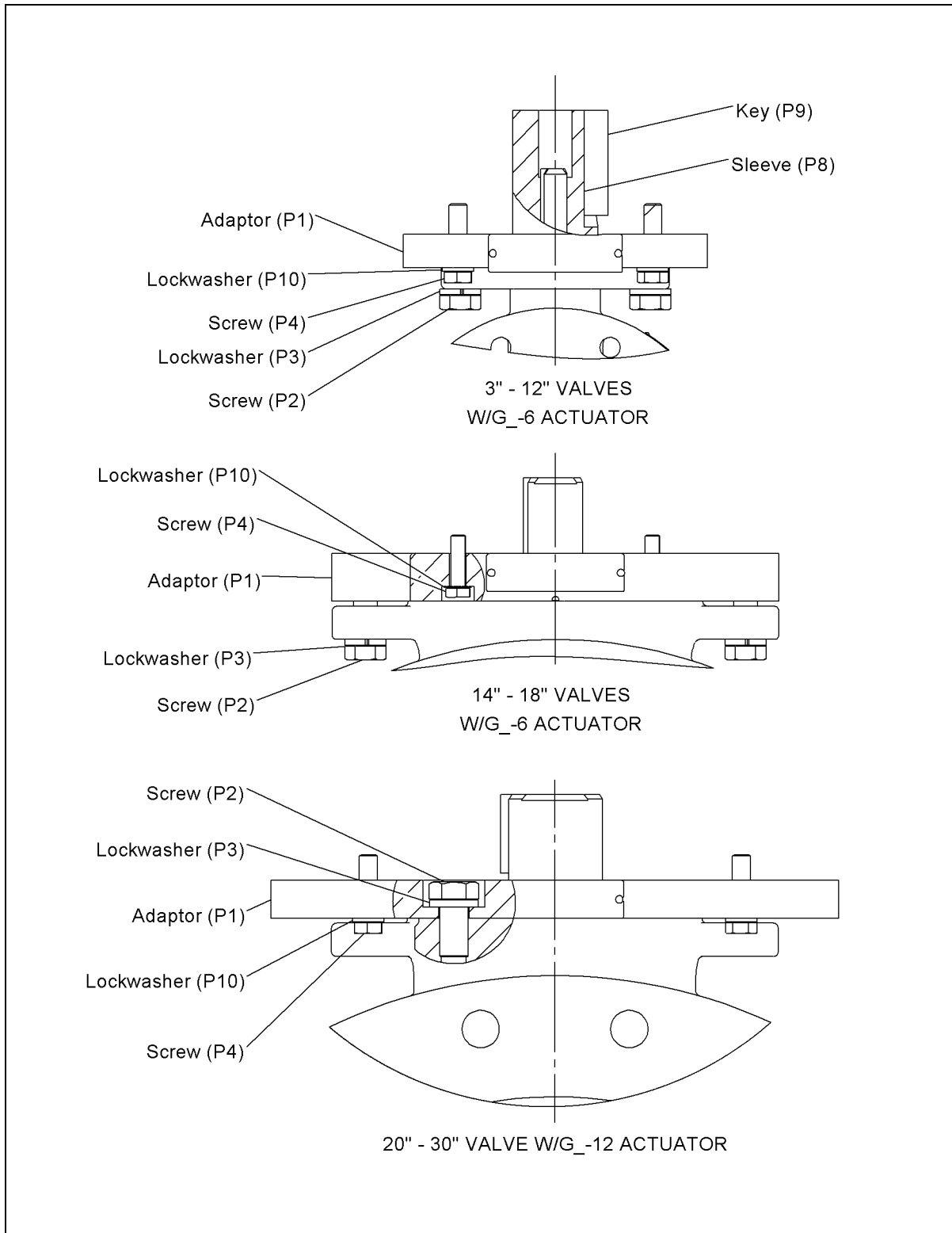

Figure 5 – Connecting Parts Identification

**Removing Actuator** *(Continued)*

---

**WARNING!**

**Flow in the pipeline with the actuator removed can slam the valve closed causing personal injury and damaging the flow system. Shut down the flow in the pipeline before removing the actuator from the valve.**

---

1. Discontinue flow and relieve pipeline pressure.
2. Close the valve.
3. Remove the four adaptor plate mounting screws (P4) and lockwashers (P10).
4. Remove the actuator from the adaptor plate (P1).
5. Do not lose the drive key used in the valve shaft and actuator gear.

**Installing Actuator**

Refer to Figure 2 and Figure 5 for parts identification.

1. Place the valve in the position it was in when the actuator was removed. Normally this will be in the closed position.
2. **For Buried Service (GB\_) actuators only:** Before reassembly, remove old sealant from all mating mounting surfaces. Apply a thin bead of silicone sealant DOW RTV-732 (1055515) or similar to the adaptor plate (P4) and the actuator housing (B1A) mounting surfaces.
3. **Above Ground Service (GS\_) actuator only:** Remove the screws (B1R) and pointer (B1Q).

**Buried Service (GB\_) actuator only:** Remove the screws (B13) and cover (B12).

4. Mount the actuator to the adaptor plate (P1) with the four mounting screws (P4) and lockwashers (P10). Tighten screws.
5. Insert the drive key into the valve shaft/gear (B1C) keyway.
6. **Above Ground Service (GS\_) actuator only:** Fasten the pointer (B1Q) to the gear (B1C) with the two screws (B1R).

**Buried Service (GB\_) actuator only:** Remove old sealant from cover (B12) and cover (B1B) mating mounting surfaces. Apply a bead of silicone sealant DOW RTV-732 (1055515) or similar to the cover (B12) and cover (B1B) mating surfaces. Fasten the cover (B12) to cover (B1B) with screws (B13).

7. Check the closed position stop setting and readjust if necessary as described in the STOP ADJUSTMENT Section of this Instruction.
8. Pipeline flow may now be restored.

### Actuator Disassembly and Assembly

Under normal operating conditions the G-Series actuator does not require routine maintenance. If the actuator has excessive wear or has been damaged, it is recommended that the actuator be replaced, not repaired.

Use the following procedure for replacing leaking seals and o-rings. Refer to Figure 2 for component identification.

#### Actuator Disassembly:

---



#### **WARNING!**

**Flow in the pipeline with the actuator removed can slam the valve closed causing personal injury and damaging the flow system. Shut down the flow in the pipeline before removing the actuator from the valve.**

---

1. Discontinue flow and relieve pipeline pressure.
2. Close the valve.
3. Remove the actuator from the valve as described in the REMOVING ACTUATOR FROM VALVE Section of this Instruction.
4. **Above Ground Service (GS\_) actuator only:** Note the position of the pointer (B1Q), then remove the screws (B1R) and pointer.  
  
**Buried Service (GB\_) actuator only:** Remove screws (B13) and cover (B12).
5. Remove the screws (B1M) and cover (B1B).
6. Remove the o-ring (B1N) thru the top of the cover (B1B).
7. Note the position of the gear (B1C) in the housing (B1A), then slide the gear (B1C) out of the housing.
8. Remove the two pipe plugs (B1I) from the housing (B1A).
9. Rotate the drive shaft (B1F) until the pins (B1K) line up with the pipe plug holes in the housing (B1A).
10. Drive both pins (B1K) thru the worm (B1D) and drive shaft (B1F).
11. Slide the drive shaft (B1F) out of the housing (B1A).
12. Remove the seal (B1J) from the housing (B1A).
13. Remove the o-ring (B1N) thru the bottom of the housing (B1A).
14. Remove old gasket sealant from the top of the housing (B1A) and bottom of the cover (B1B).

**Buried Service (GB\_) actuator only:** Remove old gasket sealant from the bottom of the housing (B1A), top of adaptor plate (P1), top of cover (B1B) and bottom of cover (B12) mating surfaces.

**Actuator Assembly:**

1. Install a new seal (B1J) into the housing (B1A).
2. Slide the drive shaft (B1F) into the housing (B1A) and thru bearing race (B1G), thrust bearing (B1H), bearing race (B1G), worm (B1D), bearing race (B1G), thrust bearing (B1H) and bearing race (B1G).
3. Rotate the drive shaft (B1F) until the pin holes in the drive shaft and the worm (B1D) line up.
4. Drive the two pins (B1K) thru the worm (B1D) and drive shaft (B1F).
5. Apply removable thread sealant to the threads of pipe plugs (B1I) and install the pipe plugs flush or below the surface of the housing (B1A).
6. Apply a light film of grease to a new o-ring (B1N) and insert it into the groove in the bottom of the housing (B1A).
7. Grease the bearing (B1L) in the housing (B1A) and slide the gear (B1C) into the bearing in the position noted in Step 7. of the ACTUATOR DISASSEMBLY section.
8. **Above Ground Service (GS\_) actuator only:** Apply a liberal amount of Lithium based grease such as Shell Alvania EP2 or Mobilux EP2 to the gear (B1C), bearings (B1L) and worm (B1D).  
  
**Buried Service (GB\_) actuator only:** Pack the housing (B1) full of Lithium based grease such as Shell Alvania EP2 or Mobilux EP2.
9. Apply a light film of grease to a new o-ring (B1N) and insert into groove in the cover (B1B).
10. Apply a bead of silicone sealant DOW RTV-732 (1055515) or similar to the housing (B1A) or cover (B1B) mating surface. Grease the bearing (B1L) in the cover, slide the cover onto the gear (B1C) and fasten with screws (B1M) to the housing.
11. Insert the drive key into the valve shaft/gear (B1C) keyway.
12. **Above Ground Service (GS\_) actuator only:** Fasten the pointer (B1Q) to the gear (B1C) with the two screws (B1R) in the position noted in Step 4. of the ACTUATOR DISASSEMBLY section.  
  
**Buried Service (GB\_) actuator only:** Apply a bead of silicone sealant DOW RTV-732 (1055515) or similar to the cover (B12) or cover (B1B) mating surface. Fasten the cover (B12) to cover (B1B) with screws (B13).
13. Install the actuator on the valve as described in the REPLACING ACTUATOR ON VALVE Section of this Instruction.

# DeZURIK

## G-Series Manual Actuator used on BAW Butterfly Valves

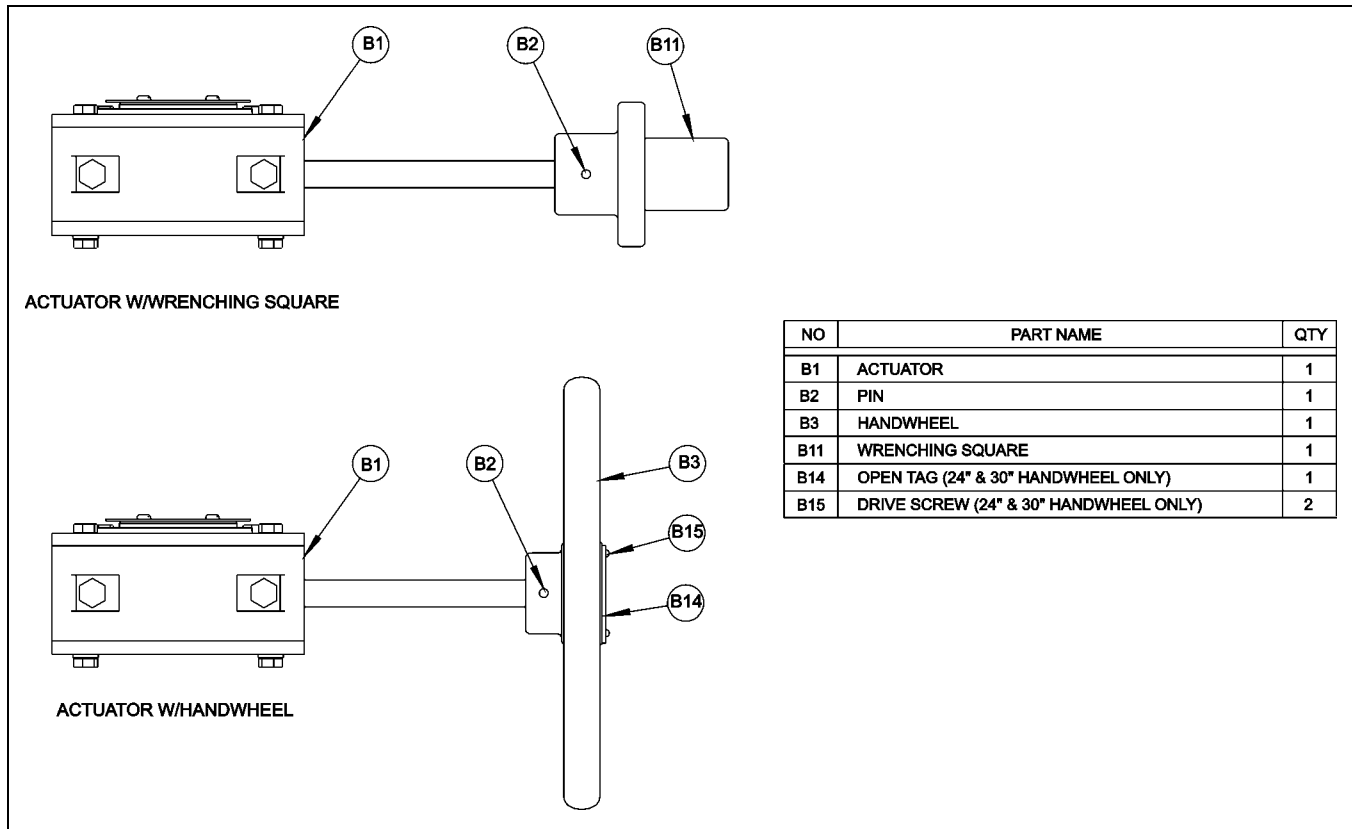

Figure 6 – Operator Component Identification

## Changing Mounting Positions

The actuator can be mounted in 90° increments around the valve shaft.

To move the actuator mounting position in 90° increments from its present position, follow these steps.

1. Remove the actuator from the valve as described in the REMOVING ACTUATOR FROM VALVE Section of this Instruction.
2. Rotate the actuator to the desired position.
3. Install the actuator on the valve as described in the REPLACING ACTUATOR ON VALVE Section of this Instruction.

**Troubleshooting**

<b>Condition</b>	<b>Possible Cause</b>	<b>Corrective Action</b>
Actuator closes to wrong position	Closed position stop is set incorrectly	Adjust closed position stop. See <i>Adjusting Position Stops</i> section
	Pointer is installed incorrectly.	Rotate pointer to correct position.
Actuator opens to wrong position	Open position stop is set incorrectly	Adjust open position stop. See <i>Adjusting Position Stops</i> section
	Pointer is installed incorrectly.	Rotate pointer to correct position.
High operating torque.	Misalignment of adaptor.	Check valve-adaptor-actuator alignment and adjust.
	Misalignment of ENK extension.	Check valve-extension-actuator alignment and adjust.
	Bent actuator input shaft.	Replace actuator.