

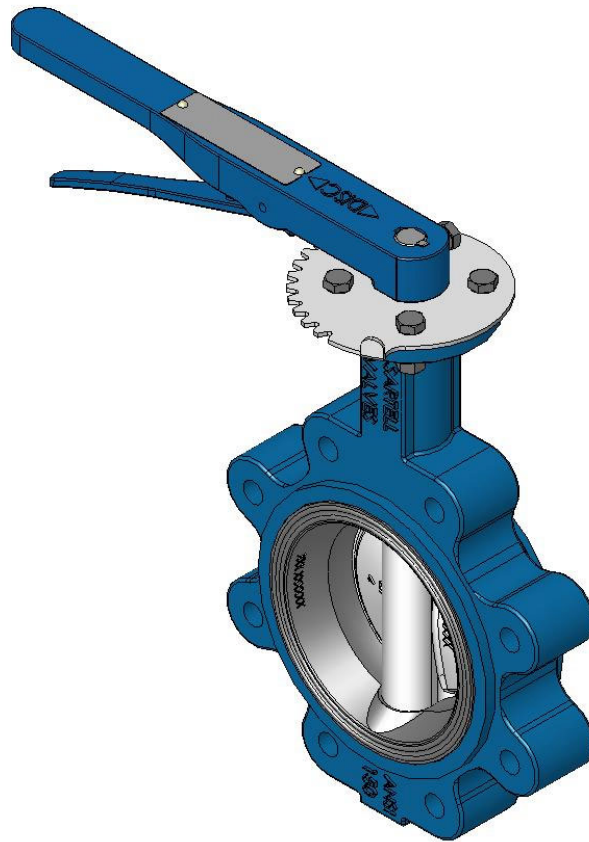

DeZURIK TEN-POSITION LEVER ACTUATOR USED ON BOS BUTTERFLY VALVES



Instruction D10461
June 2011

DeZURIK

Ten-Position Lever Actuator Used On BOS Butterfly Valves

Instructions

These instructions provide information about Lever Actuators. They are for use by personnel who are responsible for installation, operation and maintenance of Lever Actuators.

Safety Messages

All safety messages in the instructions are flagged with an exclamation symbol and the word Caution, Warning or Danger. These messages indicate procedures that must be followed exactly to avoid equipment damage, personal injury or death.

Safety label(s) on the product indicate hazards that can cause equipment damage, personal injury or death. If a safety label becomes difficult to see or read, or if a label has been removed, please contact DeZURIK for replacement label(s).



WARNING!

Personnel involved in the installation or maintenance of valves should be constantly alert to potential emission of pipeline material and take appropriate safety precautions. Always wear suitable protection when dealing with hazardous pipeline materials. Handle valves, which have been removed from service with suitable protection for any potential pipeline material in the valve.

Inspection

Your Lever Actuator has been packaged to provide protection during shipment; however, it can be damaged in transport. Carefully inspect the unit for damage upon arrival and file a claim with the carrier if damage is apparent.

Parts

Recommended spare parts are listed on the assembly drawing. These parts should be stocked to minimize downtime.

Order parts from your local DeZURIK sales representative, or directly from DeZURIK. When ordering parts, please include the 7-digit part number and 4-digit revision number (example: **9999999R000**) located on the data plate attached to the valve assembly. Also include the part name, the assembly drawing number, the balloon number and the quantity stated on the assembly drawing.

DeZURIK Service

DeZURIK service personnel are available to install, maintain and repair all DeZURIK products. DeZURIK also offers customized training programs and consultation services.

For more information, contact your local DeZURIK sales representative or visit our website at www.dezurik.com.

Table of Contents

Description - - - - -	4
Operation - - - - -	4
Locking Device - - - - -	4
Removing Actuator - - - - -	5
Installing Actuator - - - - -	5
Changing Mounting Position - - - - -	5

Description

The Ten-Position Lever is a manual actuator for 90° rotation of BOS Butterfly Valves. The actuator holds the valve in the open or closed position, or in any of eight other equally spaced intermediate positions.

Operation

To operate the actuator, firmly grasp and squeeze the end of the handle (B1-1) and the lever (B1-2) to disengage the lever from the dial (B7); then slowly rotate the handle to the desired valve position. Clockwise rotation closes the valve, and counterclockwise rotation opens the valve. Ensure that the lever is engaged in one of the 10 notches before releasing the handle. Refer to Figure 1 for parts identification.



CAUTION!

Close the valve slowly. Rapid closure of the valve can cause pipeline pressure surges that will damage pipeline equipment.

Ensure that the lever is engaged in one of the 10 notches before releasing the handle. If the lever is not engaged, the valve can slam closed and cause pipeline pressure surges that will damage pipeline equipment.

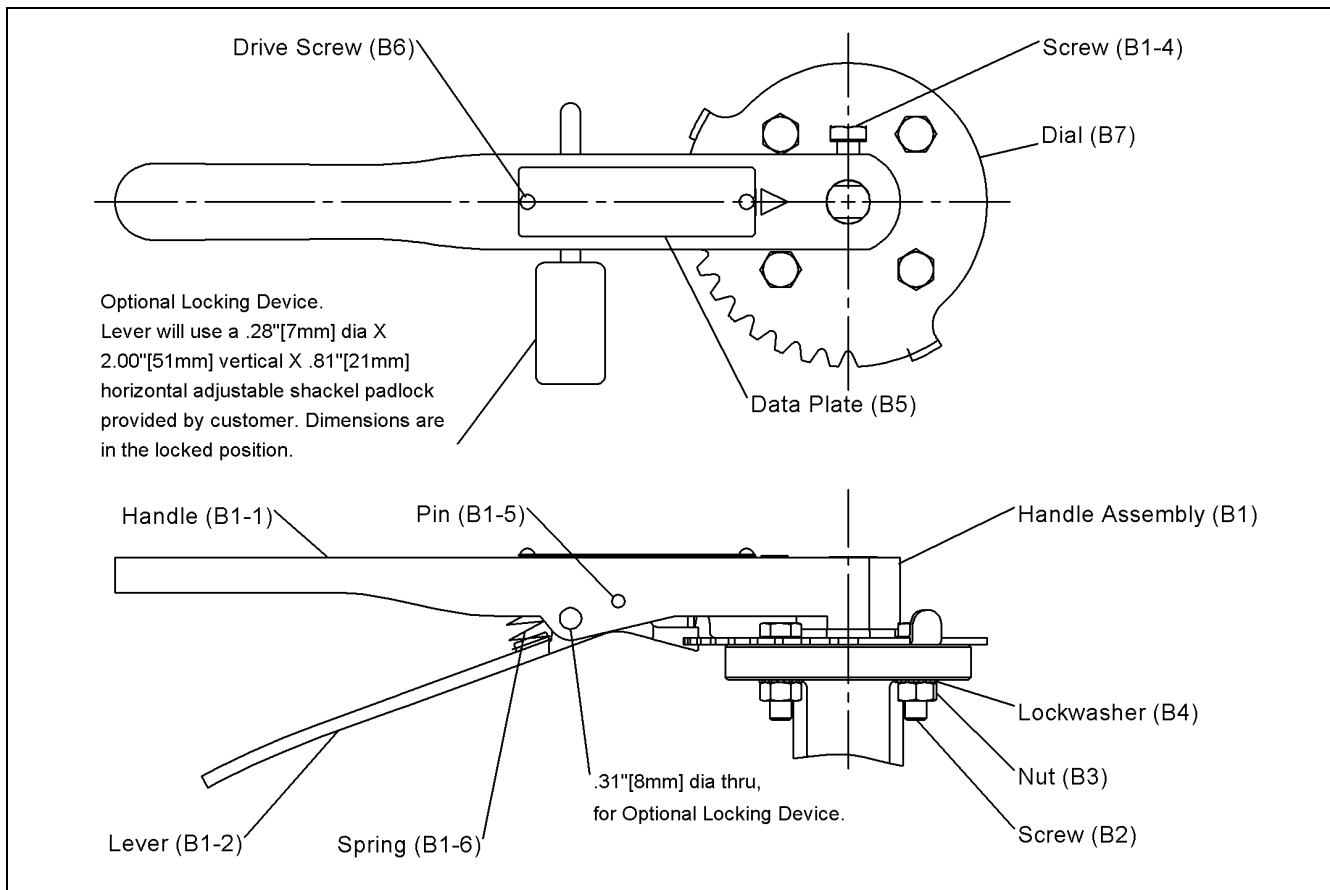

Figure 1— Parts Identification

Locking Device

A lockout feature allows the actuator to be padlocked in any of the 10 actuator positions. To lock the actuator, insert the padlock (not included) between the lever and the handle as shown in Figure 1. See recommendations below.

Padlock for the small size lever:

Master No. 510 or equivalent, with a .28" (7.1 mm) diameter removable shackle, 2.00" (50 mm) vertical clearance, and .81" (21 mm) horizontal clearance, as shown in Figure 2.

Padlock for the medium size levers:

Master No. 5 or equivalent, with a .38" (9.5 mm) diameter shackle, 2.50" (64 mm) vertical clearance, and .94" (24 mm) horizontal clearance, as shown in Figure 2.

Removing Actuator

Refer to Figure 1 for parts identification.



WARNING!

Flow in the pipeline with the actuator removed can allow the valve to slam closed and cause personal injury and/or damage to the flow system. Shut down the flow in the pipeline before removing the actuator.

1. Shut down the flow in the pipeline.
2. Close the valve.
3. Loosen the screw (B1-4) that secures the handle assembly (B1) to the valve shaft.
4. While squeezing the lever (B1-2), lift and remove the handle assembly (B1) from the valve shaft.
Note: Some valve sizes have double-D shafts and some have keyed shafts. Take care not to lose the key on valves with keyed shafts.
5. Remove the nuts (B3), lockwashers (B4) and screws (B2) from the dial (B7).
6. Remove the dial (B1-3) from the valve.

Installing Actuator

Refer to Figure 1 for parts identification.

1. Select the desired actuator mounting position. The actuator may be mounted on the valve in the standard or 180° mounting positions, as shown on the Installation Drawing for the valve.
2. Mount the dial (B7) to the top of the valve with the screws (B2), lockwashers (B4) and nuts (B3). Tighten the screws finger tight.
Note: Some valve sizes have double-D shafts and some have keyed shafts. Make sure the key is in the valve shaft before mounting the actuator on valves with keyed shafts.
3. Place the handle assembly (B1) in position on the valve shaft, and flush with the top of the valve shaft. Ensure that the lever is engaged in one of the notches.
4. Tighten the screw (B1-4) in the handle (B1-1).
5. Tighten the screws (B2), lockwashers (B4) and nuts (B3).

Changing Mounting Position



WARNING!

Flow in the pipeline with the actuator removed can allow the valve to slam closed and cause personal injury and/or damage to the flow system. Shut down the flow in the pipeline before removing the actuator.

The actuator may be mounted on the valve in the standard or 180° mounting positions, as shown on the Installation Drawing for the valve. To change to a different mounting position:

1. Remove the actuator as described in the *“Removing Actuator”* section.
2. Move the actuator to the opposite mounting position and replace the actuator on the valve as described in the *“Installing Actuator”* section.