

**SARTELL**  Valves &  
Controls

**3-20" BAW**  
**BUTTERFLY VALVES**  
WITH TRANSFER MOLDED SEAT

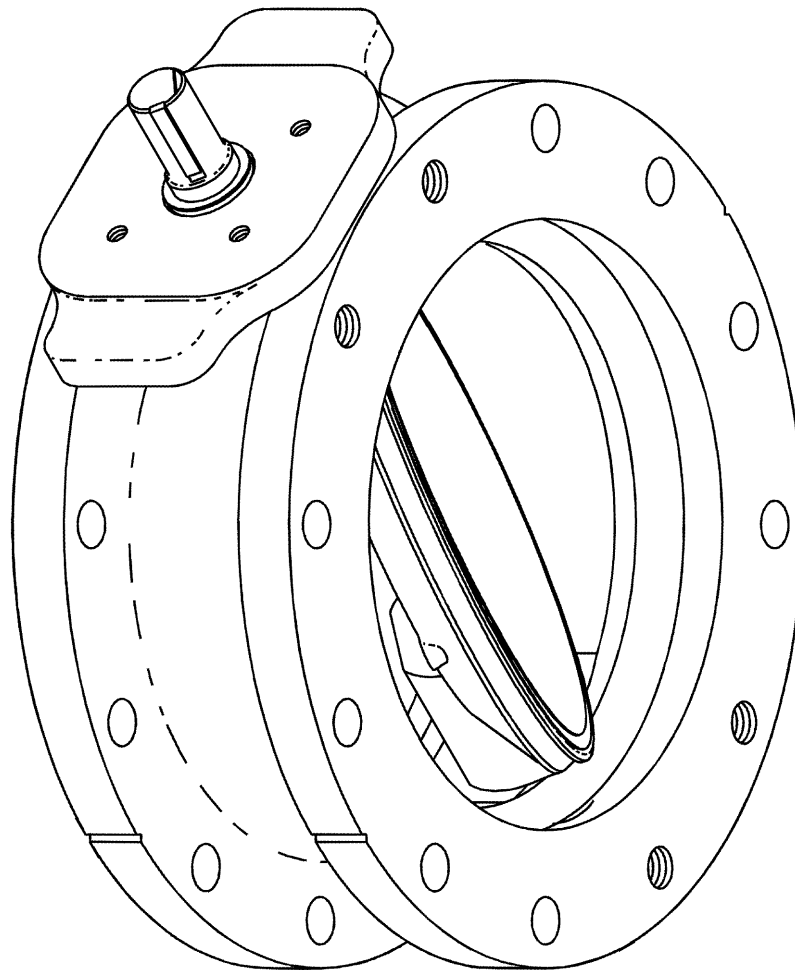

Instruction **DS10386**  
August 2008

## Instructions

These instructions provide installation, operation and maintenance information for BAW Butterfly Valves. They are for use by personnel who are responsible for installation, operation and maintenance of BAW Butterfly Valves.

## Safety Messages

All safety messages in the instructions are flagged with an exclamation symbol and the word Caution, Warning or Danger. These messages indicate procedures that must be followed exactly to avoid equipment damage, personal injury or death. Safety label(s) on the product indicate hazards that can cause equipment damage, personal injury or death.

Safety label(s) on the product indicate hazards that can cause equipment damage, personal injury or death. If a safety label becomes difficult to see or read, or if a label has been removed, please contact SARTELL Valves & Controls for replacement label(s).



### **WARNING!**

**Personnel involved in the installation or maintenance of valves should be constantly alert to potential emission of pipeline material and take appropriate safety precautions. Always wear suitable protection when dealing with hazardous pipeline materials. Handle valves, which have been removed from service with suitable protection for any potential pipeline material in the valve.**

---

## Inspection

Your BAW Butterfly Valve has been packaged to provide protection during shipment, however, it can be damaged in transport. Carefully inspect the unit for damage upon arrival and file a claim with the carrier if damage is apparent.

## Parts

Recommended spare parts are listed on the assembly drawing. These parts should be stocked to minimize downtime.

Order parts from your local SARTELL Valves & Controls sales representative, or directly from SARTELL Valves & Controls. When ordering parts, please include the 7-digit part number and 4-digit revision number (example: **9999999R000**) located on the data plate attached to the valve assembly. Also include the part name, the assembly drawing number, the balloon number and the quantity stated on the assembly drawing.

## SARTELL Valves & Controls Service

SARTELL Valves & Controls service personnel are available to install, maintain and repair all SARTELL Valves & Controls products. SARTELL Valves & Controls also offers customized training programs and consultation services.

For more information, contact your local SARTELL Valves & Controls sales representative or visit our website at [www.sartellvalves.com](http://www.sartellvalves.com).

## Table of Contents

Description - - - - -	4
Handling - - - - -	4
Maintenance - - - - -	4
Lubrication - - - - -	4
Installation - - - - -	5
<i>Requirements</i> - - - - -	5
<i>Installing Valves using Class 200 PVC</i> - - - - -	6
<i>Installing All Valves</i> - - - - -	7
Operation - - - - -	7
<i>Disc Position Indicator</i> - - - - -	7
<i>Position Stops</i> - - - - -	7
Drawings - - - - -	8
Adjusting Packing - - - - -	10
<i>Valves without Packing Gland</i> - - - - -	10
<i>Valves with Packing Gland</i> - - - - -	10
Replacing Packing	
<i>Valves without Packing Gland</i> - - - - -	11
<i>Valves with Packing Gland</i> - - - - -	11
Removing Valve - - - - -	12
Disassembling Valve - - - - -	13
<i>Removing the Disc/Shaft from Body</i> - - - - -	13
Reassembling Valve - - - - -	13
Replacing Bearings - - - - -	15
Troubleshooting - - - - -	16

## **Description**

The 3-20" BAW AWWA Butterfly Valve is a resilient seated bi-directional valve that meets all class 150 requirements of ANSI/AWWA standard C504. Flanged and mechanical joints are offered. Pressure and temperature ratings are shown on the valve data plate

## **Handling**

Lifting the valve improperly may damage it. Do not fasten lifting devices to the actuator, disc or through the seat opening in the body. Lift the valve with slings, chains or cables fastened around the valve body, or fastened to bolts or rods through bolt holes in the flanges.

## **Maintenance**

This valve is assembled using standard SAE fasteners. To service this valve, you should have a full set of combination wrenches, flat tipped screwdrivers, Allen wrenches, a torque wrench, sockets, chisels, a hooked tool for removing the packing and a dead blow hammer.

## **Lubrication**

The valve is lubricated at the factory, and does not require routine lubrication. When installing valve or if maintenance is required, refer to the appropriate sections for lubrication requirements and use an NSF 61 approved lubricant (such as Dow Corning 111 or Phoenix 505).

Refer to the actuator instructions for actuator lubrication requirements.

## Installation

Mount the actuator on the valve before installation. For a SARTELL Valves & Controls actuator, see actuator instructions.

For other actuators:

- On valves with non-adjustable packing, the actuator interface must include a retaining plate for the packing.
- On valves with adjustable packing, the actuator interface must provide clearance for the packing gland and access for packing adjustment. Dimensional requirements are shown on the installation drawing for the valve.

Lifting the valve improperly may damage it. Do not fasten lifting devices to the actuator, disc or through the seat opening in the body. Lift the valve with slings, chains or cables fastened around the valve body, or fastened to bolts or rods through bolt holes in the flanges.

Refer to the installation drawing for dimensions and to identify components.

## Requirements



### CAUTION!

**PVC pipe that does not meet AWWA standards may damage the valve. If PVC pipe is used with mechanical joint valves, the pipe O.D. must comply with AWWA C905-97, Table 2 "PVC PIPE WITH CAST IRON PIPE EQUIVALENT O.D.'S."**

---

- Flanged connections require mating flanges that comply with ASME/ ANSI B16.1 Class 125 or Class 150. Flange gaskets are also required.
- Mechanical joints must comply with ANSI/AWWA C111/A21.11.
- To reduce the effects of downstream disturbances, install the valve at least the distance of eight pipe diameters downstream from the closest elbow or pump.
- If valve is used in pumpcheck applications, install the valve with the seat end nearer the pump.
- If possible, install the valve with the shaft horizontal to provide self-cleaning action.

**Installation (Continued)**

**Installing Valves using Class 200 PVC**

When installing valves with mechanical joint ends on Class 200 (DR 14 or higher) PVC pipe, call SARTELL Valves & Controls customer service if you have any problems or questions with this procedure

1. Chamfer the ID of the pipe as shown in Table A to provide clearance for the valve disc.

**Table A: Chamfer Requirements**

Valve Size	Pipe Pressure Class	Pipe Dimension Ratio	Chamfer Seat Side	Chamfer Opposite Seat	Min. Chamfer Dia. (in)	Chamfer Angle
4	200	14	No	No	N/A	N/A
6	200	14				
8	200	14				
10	200	14	Yes	No	9.62"	30°
12	200	14	Yes	No	11.75"	30°
14	200	21	Yes	No	13.75"	30°
	235	18	Yes	No	13.88"	30°
	305	14	Yes	Yes	14.00"	30°
16	165	25	No	No	N/A	N/A
	200	21				
	235	18	Yes	No	15.68"	30°
	305	14	Yes	Yes	15.88"	30°
18	165	25	No	No	" N/A	N/A
	200	21				
	235	18	Yes	No	17.38"	30°
	305	14	Yes	Yes	17.50"	30°
20	165	25	Yes	Yes	41.50"	20°
	200	21	Yes	No	19.56"	30°
	305	18	Yes	No	19.56"	30°

\*Call SARTELL Valves & Controls customer service if you have any questions on this procedure.

2. Cycle the valve for three full open–close cycles to ensure disc fully clears the pipe.

## Installation (Continued)

### Installing All Valves

1. Thoroughly clean the pipeline, valve and flanges of all debris, which could damage the seat, disc or bearings.
2. Open the valve, clean the seat and sealing edge of the disc, then apply a paint-like coating of an NSF 61 approved lubricant (such as Dow Corning 111 or Phoenix 505) to the seat.
3. Close the valve and tighten the bolts evenly in a crisscross pattern.

**Note:** Ensure the pipeline, valve and flanges are properly aligned. Do not use the valve to force the pipeline into position.

Due to varying conditions during shipment, storage, handling and installation, it is recommended that each valve be tested while the valve is accessible in the pipeline.

## Operation

Turning the valve shaft clockwise closes the valve. The valve is fully closed when the disc is centered on the seat; valve is fully open when the disc is 90° counterclockwise from the closed position.

### Disc Position Indicator

The indicator notch on top of the valve shaft corresponds with the seat side of the disc. The location of the indicator notch is shown in Figure 1.

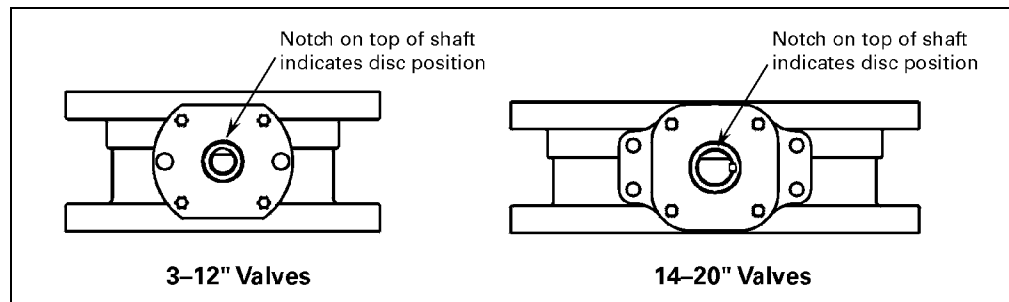
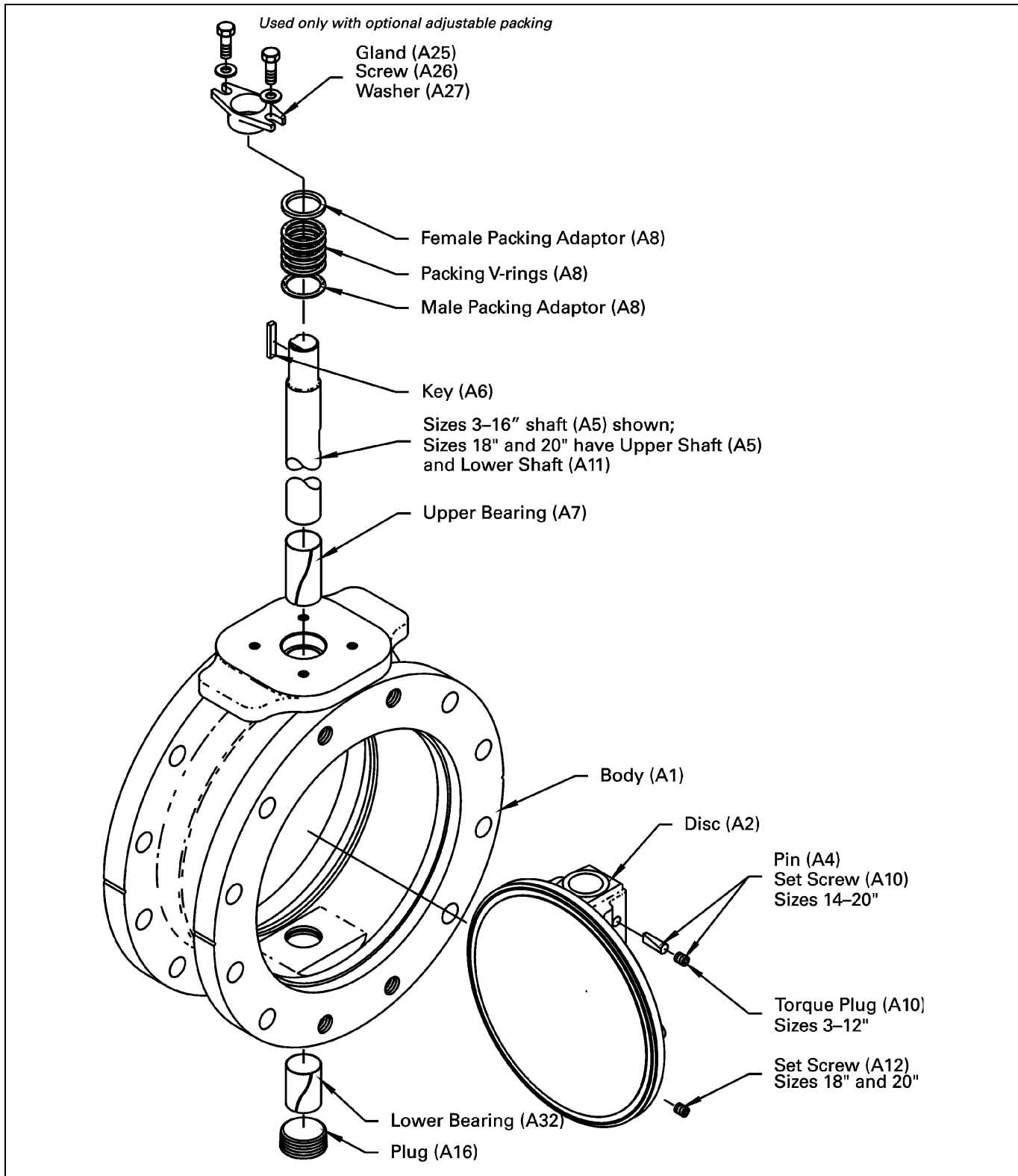

**Figure 1—Disc Indicator Location**

### Position Stops

The valve actuator is connected to the valve shaft and positions the disc at the open, closed or intermediate positions. Installed SARTELL Valves & Controls actuators come with the position stops pre-adjusted. For other actuators, refer to actuator instructions to adjust the position stops.

**Drawings**



**Figure 2—Disassembled 3-20" AWWA Butterfly Valve**

**Drawings** (Continued)

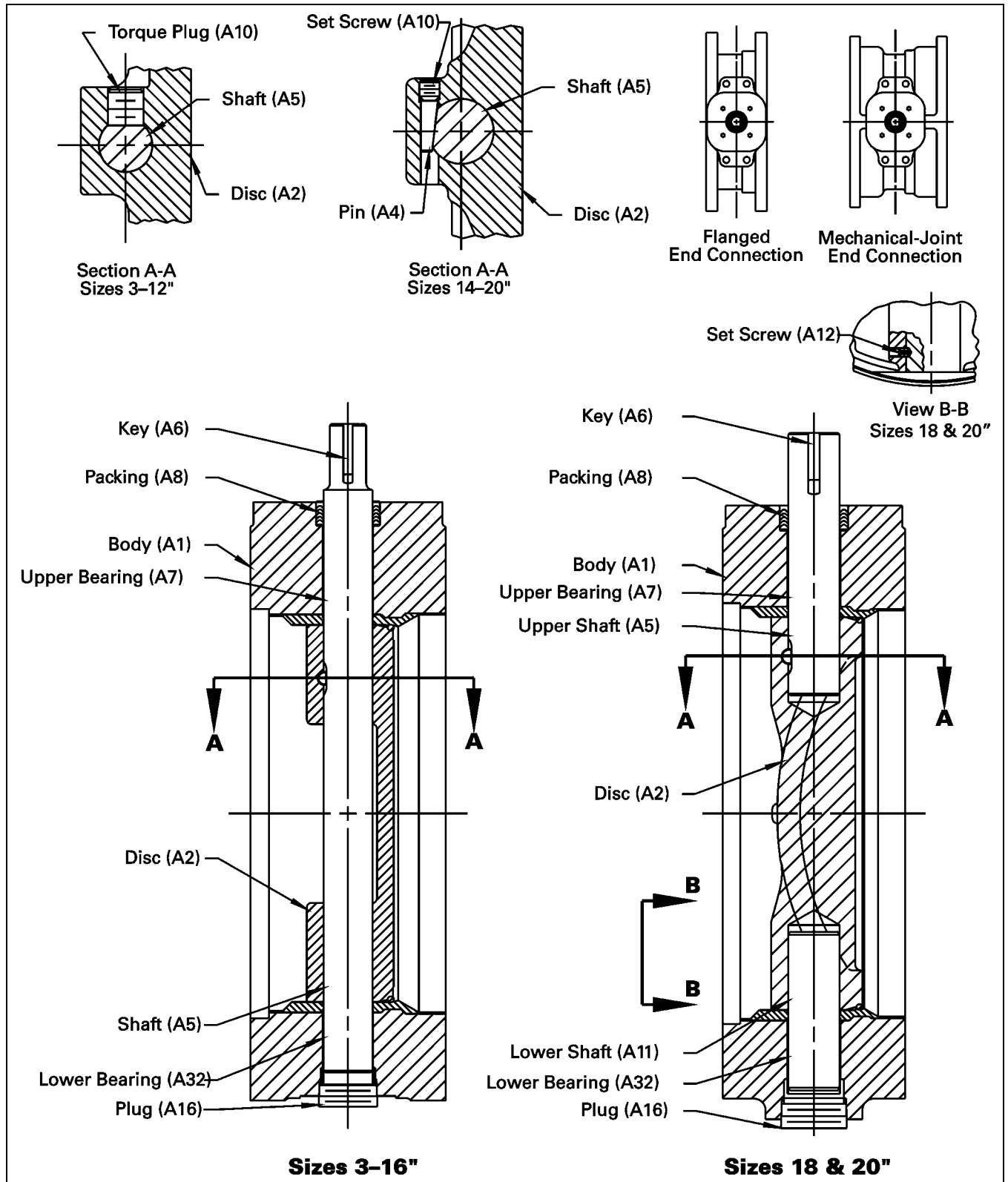

**Figure 3—Assembled 3-20" AWWA Butterfly Valve**

## Adjusting Packing

See Figure 2 to identify parts.

### *Valves without Packing Gland*

---



**WARNING!**

**Removing the valve while the pipeline is under pressure can cause personal injury or equipment damage. Relieve pipeline pressure before removing the valve.**

---

1. Relieve the pressure in the pipeline and close the valve.
- 



**WARNING!**

**Accidental operation of power actuator can cause personal injury or equipment damage. Disconnect and lock out power to actuator before servicing.**

---

2. If the actuator is powered, disconnect and lock out the pneumatic, hydraulic or electrical power to prevent accidental operation of the actuator.
3. Remove the actuator (and adapter, if included) from the valve.
4. Slide spacers down the valve shaft so that they protrude 1/32–1/16" above the body.  
**Note:** Spacers can be Garlock style 7857/260 rock hard rubber; Grade A, D or E Bronze; or 316 stainless steel.
5. Replace the actuator on the valve.
6. If packing continues to leak, replace the packing.

### *Valves with Packing Gland*

If the packing leaks on valves with a packing gland, tighten the packing gland nuts just enough to stop the leak; over-tightening will cause excessive operating torques and premature packing wear. If the leak cannot be stopped by tightening the packing nuts, replace the packing.

## Replacing Packing

### Valves without Packing Gland

---



**WARNING!**

**Removing the valve while the pipeline is under pressure can cause personal injury or equipment damage. Relieve pipeline pressure before removing the valve.**

---

1. Relieve the pressure in the pipeline and close the valve.
- 



**WARNING!**

**Accidental operation of power actuator can cause personal injury or equipment damage. Disconnect and lock out power to actuator before servicing.**

---

2. If the actuator is powered, disconnect and lock out the pneumatic, hydraulic, or electrical power to prevent accidental operation of the actuator.
3. Remove the actuator (and adaptor if included) from the valve
4. Remove all of the packing rings (A8) from the packing chamber with a hooked tool.
5. Apply a paint-like coat of an NSF 61 approved lubricant (such as Dow Corning 111 or Phoenix 505) to the inside and outside diameters of the new packing, then install the new packing one ring at a time.

**Note:** Start each chevron ring into the packing chamber at a slight angle and push each ring carefully into position so that the sealing lips do not bend over. Push the packing firmly into place. Do not use a sharp or pointed tool.

6. Replace the actuator adaptor (if included) and the actuator on the valve.

### Valves with Packing Gland

---



**WARNING!**

**Removing the valve while the pipeline is under pressure can cause personal injury or equipment damage. Relieve pipeline pressure before removing the valve.**

---

1. Relieve the pressure in the pipeline and close the valve.
- 



**WARNING!**

**Accidental operation of power actuator can cause personal injury or equipment damage. Disconnect and lock out power to actuator before servicing.**

---

2. If the actuator is powered, disconnect and lock out the pneumatic, hydraulic, or electrical power to prevent accidental operation of the actuator.

## Replacing Packing *(Continued)*

3. Remove the actuator (and adaptor if included) from the valve.
4. Remove the two screws (A26) and the gland (A25).
5. Pull all of the packing rings (A8) from the packing chamber with a hooked tool.
6. Apply a paint-like coat of an NSF 61 approved lubricant (such as Dow Corning 111 or Phoenix 505) to the inside and outside diameters of the new packing, then install the new packing one ring at a time.

**Note:** Start each chevron ring into the packing chamber at a slight angle and push each ring carefully into position so that the sealing lips do not bend over. Push the packing firmly into place. Do not use a sharp or pointed tool.

7. Replace the gland (A25), the two screws (A26) and washers (A27).
8. Tighten the screws in a criss-cross pattern until finger-tight, plus ½ turn.
9. Replace the actuator adaptor (if included) and the actuator on the valve.
10. Pressurize the valve and check for leaks.
11. If packing leaks, tighten the two adjustment screws (A26) on the packing gland. Tighten the screws evenly and gently, just enough to stop the leakage. Over-tightening will cause excessive operating torque and will decrease the life of the packing.
12. If the actuator is a powered actuator, reconnect power to the actuator.

## Removing Valve

Lifting the valve improperly may damage it. Do not fasten lifting devices to the actuator, disc or through the seat opening in the body. Lift the valve with slings, chains or cables fastened around the valve body or fastened to bolts or rods through bolt holes in the flanges.



### **WARNING!**

**Removing the valve while the pipeline is under pressure can cause personal injury or equipment damage. Relieve pipeline pressure before removing the valve.**

---

1. Relieve pipeline pressure and drain the section near the valve and close the valve.



### **WARNING!**

**Accidental operation of power actuator can cause personal injury or equipment damage. Disconnect and lock out power to actuator before servicing.**

---

2. If the actuator is powered, disconnect and lock out the pneumatic, hydraulic or electrical power to the actuator.
3. Support the valve assembly, remove the flange bolts or mechanical joint connections then remove the valve from the pipeline.

## Disassembling Valve

Before disassembly, remove the valve from the pipe line, open the valve and remove actuator (and adapter, if included) from the valve. See the "REMOVING VALVE" section. See Figures 1 and 2 for component identification.

### ***Removing the Disc/Shaft from Body***

1. If the valve has packing gland, remove the two screws (A26), and the gland (A25).
2. Remove the plug (A16) from the bottom of the valve.
3. Remove the disc-to-shaft assembly:
  - On sizes 3–12", remove the torque plug (A10).
  - On sizes 14–20", remove the set screw (A10) and drive out the pin (A4) from the side opposite the set screw with a hammer and punch. Do not damage the shaft with the punch.
  - On sizes 18 and 20", also remove the lower set screw (A12).
4. Remove the shaft from the valve body:
  - On sizes 3–16", push the bottom end of the shaft (A5) and carefully remove the shaft from the top of the body.
  - On sizes 18 and 20", turn a threaded fastener into the threaded hole on the lower shaft (A11). Using the threaded fastener, carefully remove the shaft from the body.
5. Remove the disc (A2) from the side of the body opposite seating side.

## Reassembling Valve

1. Block the body (A1) in a horizontal position with the seat facing down.

**Note:** Provide clearance for the disc above and below the seat opening.
2. Apply a paint-like coating of an NSF 61 approved lubricant (such as Dow Corning 111 or Phoenix 505) to the two flat pads near the holes for the shaft.
3. Holding the disc (A2) in a vertical "OPEN" position, with the shaft connection toward the top of the body, insert the disc into the seat opening in the body and align the shaft holes in the disc with the shaft holes in the body.
4. Insert the shaft into the body and disc:
  - On sizes 3–16", insert the shaft (A5) into the top of the body, through the disc and into the bottom of the body. Insert the shaft carefully so that the body bearings (A7 and A32) are not damaged or moved out of position.
  - On sizes 18 and 20", insert the upper shaft (A5) through the top of the body and into the top of the disc. Insert the shaft carefully so that the upper body bearing (A7) is not damaged or moved out of position. Align and center the flat on the shaft with the tapped hole in the disc. Insert the lower shaft (A11) through the bottom of the body and into the bottom of the disc. Insert the shaft carefully so that the lower body bearing (A32) is not damaged or moved out of position. Align and center the hole in the lower shaft with the tapped hole in the disc.

**Reassembling Valve** (Continued)

5. Connect the disc to the shaft:

- On sizes 3–12", align and center the flat on the shaft with the tapped hole in the disc. See Figure 4. On sizes 3–6", apply one bead of Loctite 242 along half the depth of the threads tapped hole; on sizes 8–12", apply two beads, on opposite sides. Apply one bead to the threads of the torque plug (A10) and screw the torque plug into the disc and tighten to the torque shown in Table B.

**Table B Plug Torque**

Valve Size	Torque, Ft. Lbs.
3	13+/-2
4	20 +/-2
6	60+/-5
8	85+/-5
10	130+/-5
12	190+/-5

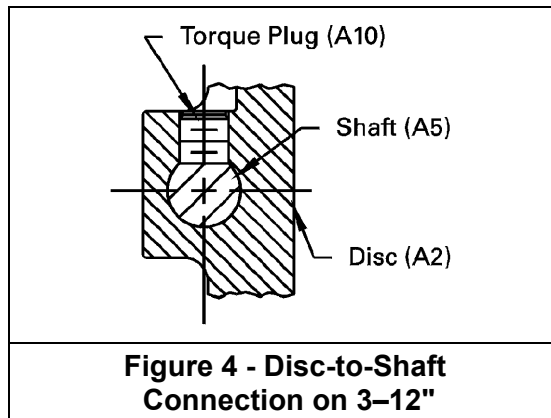

- On sizes 14–16", align and center the flat on the shaft with the tapped hole in the disc. Insert the pin (A4) into the mating hole in the disc (A2) so that the flat on the pin is centered on the flat on the shaft. Tap the pin firmly into position with a hammer and punch until the hammer bounces back when the pin is struck. Apply one bead of Loctite 242 to the threads of set screw (A10) and one bead along half the depth of the threads in the tapped hole above the pin. Tighten the set screw to 75±5 ft. lbs. See Figure 5.

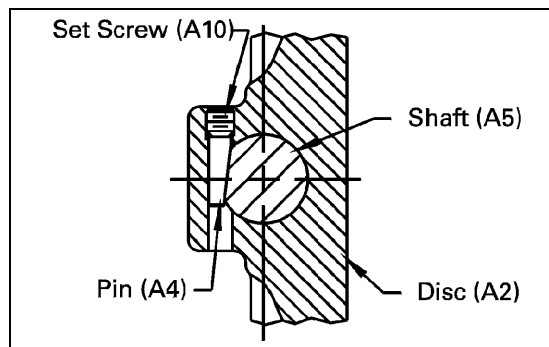

## Reassembling Valve (Continued)

- On sizes 18 and 20", align and center the flat on the shaft with the tapped hole in the disc. Insert the pin (A4) into the mating hole in the disc (A2) so that the flat on the pin is centered on the flat on the shaft. Tap the pin firmly into position with a hammer and punch until the hammer bounces back when the pin is struck. Apply one bead of Loctite 242 to the threads of the set screw (A10) and one bead along half the depth of the threads in the tapped hole above the pin. Tighten the set screw to  $125 \pm 5$  ft. lbs. See Figure 5. Apply one bead of Loctite 242 to the threads of set screw (A12) and one bead along half the depth of the threads in the threaded hole near the bottom of the disc (A2). Thread the set screw into the disc and into the blind hole in the lower shaft (A11) and tighten to  $13 \pm 2$  ft. lbs. See Figure 6.

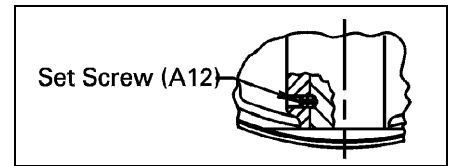

**Figure 6—Lower Set Screw  
Detail 18" & 20"**

6. Apply PTFE pipe sealant to the threads of plug (A16) and tighten the plug securely in the threaded hole in the bottom of the body.
7. If the valve has a packing gland, mount the gland (A25) with the two screws (A26) and washers (A27). Tighten the screws evenly and finger-tight, plus 1/2 turn.
8. Mount the actuator (and adapter, if included) to the valve.

## Replacing Bearings

1. To replace bearing, disassemble the valve as instructed in the "disassembling valve" section.
2. Remove the bearings from the upper and lower journals in the valve body.  
**Note:** If PFTE or Darcon bearings are used, fabricate a sleeve the same size as the bearing OD; insert the sleeve into the bearing, and push the bearing out of the journal.
3. Thoroughly clean the journals before inserting new bearings.
4. Form new bearings into cylindrical shape and insert bearings into the journals until they stop against the rubber seat ring or are 1/8" away from the body opening.  
**Note:** For 3-8" valves, warm the bearing to 350°F (177°C) before forming into the cylindrical shape to avoid crimping the bearing material.
5. For PFTE or Darcon bearings, apply a layer of Loctite to the outside surface of bearing, then use sleeve to push it into the journal until it stops against the body step.
6. Reassemble the valve as described in the "reassembling valve" section.

## Troubleshooting

Condition	Possible Cause	Corrective Action
Packing leaks.	Packing is loose.	Adjust packing See "Packing Adjustment."
	Packing is worn.	Replace Packing. See "Packing Replacement."
Valve leaks when closed.	Closed position stop is set incorrectly.	Adjust closed position stop
	Seat is worn or Damaged.	Replace valve.
	Sealing edge of disc is worn or damaged.	Replace disc.
Valve does not fully close.	Object is wedged between seat and disc.	Fully open valve to remove object.
	Closed position stop is not set correctly.	Adjust closed position stop.
Valve does not fully open.	Open position stop is not adjusted correctly.	Adjust open position stop.
Opening and/or closing torque is excessive.	Bearings, shaft, disc and/or seat are dirty or worn.	Clean or replace dirty or worn component(s).
	Shaft is bent.	Replace shaft.
	Packing gland screws are over-tightened.	Loosen screws and replace packing if needed.

## Guarantee

Products, auxiliaries and parts thereof of Sartell Valves, Inc. manufacture are warranted to the original purchaser for a period of twenty-four (24) months from date of shipment from factory, against defective workmanship and material, but only if properly installed, operated and serviced in accordance with Sartell Valves, Inc. recommendations. Repair or replacement, at our option, for items of Sartell Valves, Inc. manufacture will be made free of charge, (FOB) our facility with removal, transportation and installation at your cost, if proved to be defective within such time, and this is your sole remedy with respect to such products. Equipment or parts manufactured by others but furnished by Sartell Valves, Inc. will be repaired or replaced, but only to the extent provided in and honored by the original manufacturers warranty to Sartell Valves, Inc., in each case subject to the limitations contained therein. No claim for transportation, labor or special or consequential damages or any other loss, cost or damage shall be allowed. You shall be solely responsible for determining suitability for use and in no event shall Sartell Valves, Inc. be liable in this respect. Sartell Valves, Inc. does not guarantee resistance to corrosion, erosion, abrasion or other sources of failure, nor does Sartell Valves, Inc. guarantee a minimum length of service. Your failure to give written notice to us of any alleged defect under this warranty within twenty (20) days of its discovery, or attempts by someone other than Sartell Valves, Inc. or its authorized representatives to remedy the alleged defects therein, or failure to return product or parts for repair or replacement as herein provided, or failure to install and operate said products and parts according to instructions furnished by Sartell Valves, Inc., or misuse, modification, abuse or alteration of such product, accident, fire, flood or other Act of God, or failure to pay entire contract price when due shall be a waiver by you of all rights under this warranty.

The foregoing guarantee shall be null and void if, after shipment from our factory, the item is modified in any way or a component of another manufacturer, such as but not limited to, an actuator is attached to the item by anyone other than Sartell Valves, Inc. Factory Service personnel. All orders accepted shall be deemed accepted subject to this limited warranty, which shall be exclusive of any other or previous Warranty, and this shall be the only effective guarantee or warranty binding on Sartell Valves, Inc., despite anything to the contrary contained in the purchase order or represented by any agent or employee of Sartell Valves, Inc., in writing or otherwise, notwithstanding, including but not limited to implied warranties.

THE FOREGOING REPAIR AND REPLACEMENT OBLIGATIONS ARE IN LIEU OF ALL OTHER WARRANTIES, OBLIGATIONS AND LIABILITIES, INCLUDING ALL WARRANTIES OF FITNESS FOR A PARTICULAR PURPOSE OR OF MERCHANTABILITY OR OTHERWISE, EXPRESSED OR IMPLIED IN FACT OR BY LAW, AND STATE SARTELL VALVES, INC.'S ENTIRE AND EXCLUSIVE LIABILITY AND YOUR EXCLUSIVE REMEDY FOR ANY CLAIM IN CONNECTION WITH THE SALE AND FURNISHING OF SERVICES, GOODS OR PARTS, THEIR DESIGN, SUITABILITY FOR USE, INSTALLATION OR OPERATIONS.

## Limitation of liability

LIMITATION OF LIABILITY: IN NO EVENT SHALL SARTELL VALVES, INC. BE LIABLE FOR ANY DIRECT, INDIRECT, SPECIAL OR CONSEQUENTIAL DAMAGES WHATSOEVER, AND SARTELL VALVES, INC.'S LIABILITY, UNDER NO CIRCUMSTANCES, WILL EXCEED THE CONTRACT PRICE FOR THE GOODS AND/OR SERVICES FOR WHICH LIABILITY IS CLAIMED. ANY ACTION BY YOU FOR BREACH OF CONTRACT MUST BE COMMENCED WITHIN 12 MONTHS AFTER THE DATE OF SALE.

## Sales and Service

For information about our worldwide locations, approvals, certifications and local representative:

Web site: [www.sartellvalves.com](http://www.sartellvalves.com)

E-Mail: [info@sartellvalves.com](mailto:info@sartellvalves.com)

**SARTELL** Valves, Inc.



250 Riverside Ave. N., Sartell, MN 56377 • Phone: 320-259-2000 • Fax: 320-259-2227

*Sartell Valves, Inc. reserves the right to incorporate our latest design and material changes without notice or obligation. Design features, materials of construction and dimensional data, as described in this manual, are provided for your information only and should not be relied upon unless confirmed in writing by Sartell Valves, Inc. Certified drawings are available upon request.*