

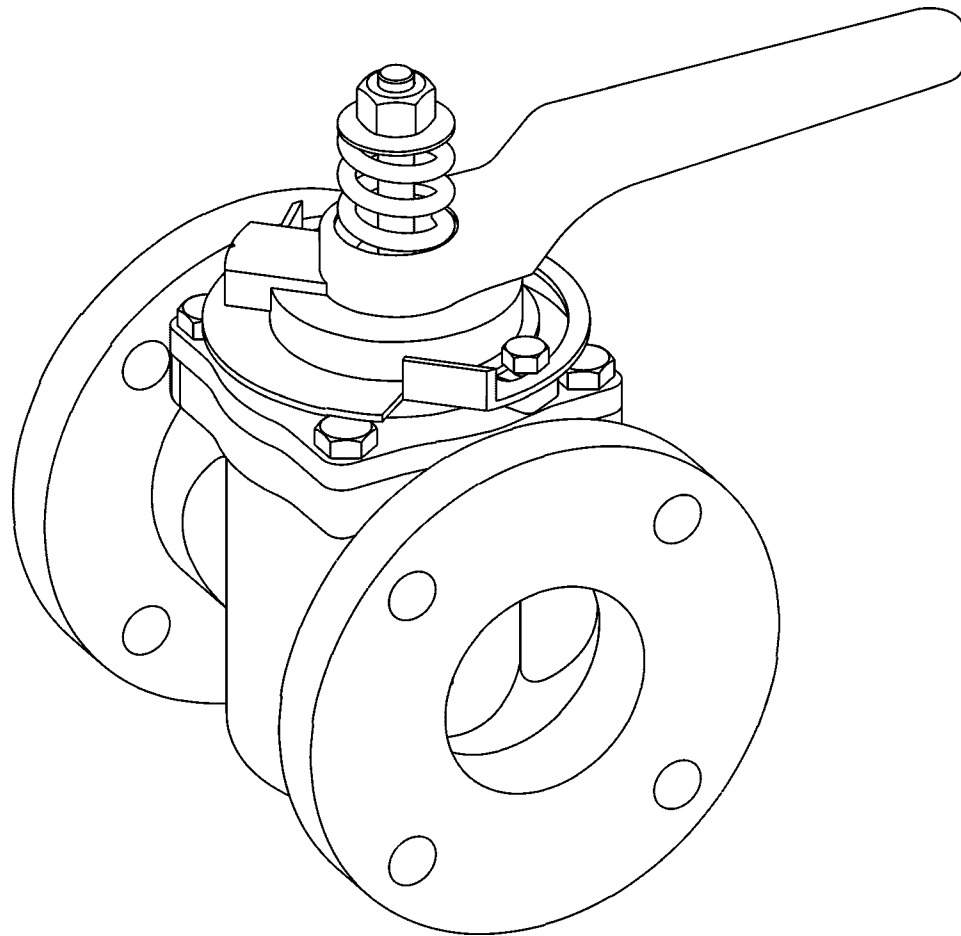

# 1/2-3" PEC ECCENTRIC VALVES



Instruction D10095  
March 2010

# DeZURIK

## 1/2–3" PEC Eccentric Valves

---

### Instructions

These instructions provide information about PEC Eccentric Valves. They are for use by personnel who are responsible for installation, operation and maintenance of PEC Eccentric Valves.

### Safety Messages

All safety messages in the instructions are flagged with an exclamation symbol and the word Caution, Warning or Danger. These messages indicate procedures that must be followed exactly to avoid equipment damage, personal injury or death. Safety label(s) on the product indicate hazards that can cause equipment damage, personal injury or death. If a safety label becomes difficult to see or read, or if a label has been removed, please contact DeZURIK for replacement label(s).



#### **WARNING!**

**Personnel involved in the installation or maintenance of valves should be constantly alert to potential emission of pipeline material and take appropriate safety precautions. Always wear suitable protection when dealing with hazardous pipeline materials. Handle valves, which have been removed from service with suitable protection for any potential pipeline material in the valve.**

---

### Inspection

Your PEC Eccentric Valve has been packaged to provide protection during shipment, however, it can be damaged in transport. Carefully inspect the unit for damage upon arrival and file a claim with the carrier if damage is apparent.

### Parts

Recommended spare parts are listed on the assembly drawing. These parts should be stocked to minimize downtime.

Order parts from your local DeZURIK sales representative, or directly from DeZURIK. When ordering parts, please include the 7-digit part number and 4-digit revision number (example: **9999999R000**) located on the data plate attached to the valve assembly. Also include the part name, the assembly drawing number, the balloon number and the quantity stated on the assembly drawing.

### DeZURIK Service

DeZURIK service personnel are available to install, maintain and repair all DeZURIK products. DeZURIK also offers customized training programs and consultation services.

For more information, contact your local DeZURIK sales representative or visit our website at [www.dezurik.com](http://www.dezurik.com).

## Table of Contents

Description - - - - -	4
Required Tools - - - - -	4
Installation - - - - -	4
Lubrication - - - - -	6
Stem Seal Adjustment	
<i>Lever Actuator</i> - - - - -	6
<i>Powered Actuator (Powerrac, G-Unit or Compact)</i> - - - - -	6
Closed Position - - - - -	6
Disassembly - - - - -	7
Reassembly - - - - -	8
Removing Valve from Pipeline - - - - -	9
Field Test - - - - -	9
Emergency Operation - - - - -	9
Predicted Wear of Parts - - - - -	9
Troubleshooting - - - - -	10

# DeZURIK

## 1/2–3" PEC Eccentric Valves

### Description

The 1/2 - 3" PEC Eccentric Valve is a quarter turn valve. Clockwise rotation of the valve stem 90 degrees closes the valve.

If an actuator other than DeZURIK is to be mounted on the valve, the actuator must be capable of maintaining the valve plug position with flow in the pipeline.



#### **WARNING!**

**This valve is a pressure vessel. Pressure must be completely released before disassembly. The bonnet will blow off if the bonnet bolts are removed with pressure in the valve.**

### Required Tools

This valve is assembled using only SAE fasteners. To service this valve, you should have a full set of combination wrenches, Allen wrenches, a large flat tipped screwdriver, a flat pry bar, a pin punch and a dead blow hammer.

*Note:* You may want to machine a shaft to aid you in removing the lower bearing from the body. See "Disassembly" section.

### Installation

The type of materials carried in the pipeline and the location of the valve determine the correct installation procedure.

#### **Liquids and Gases**

1. Before installation, remove foreign material such as weld spatter, oil, grease, and dirt from the valve and pipeline.
2. Install the valve as shown in Figure 1.

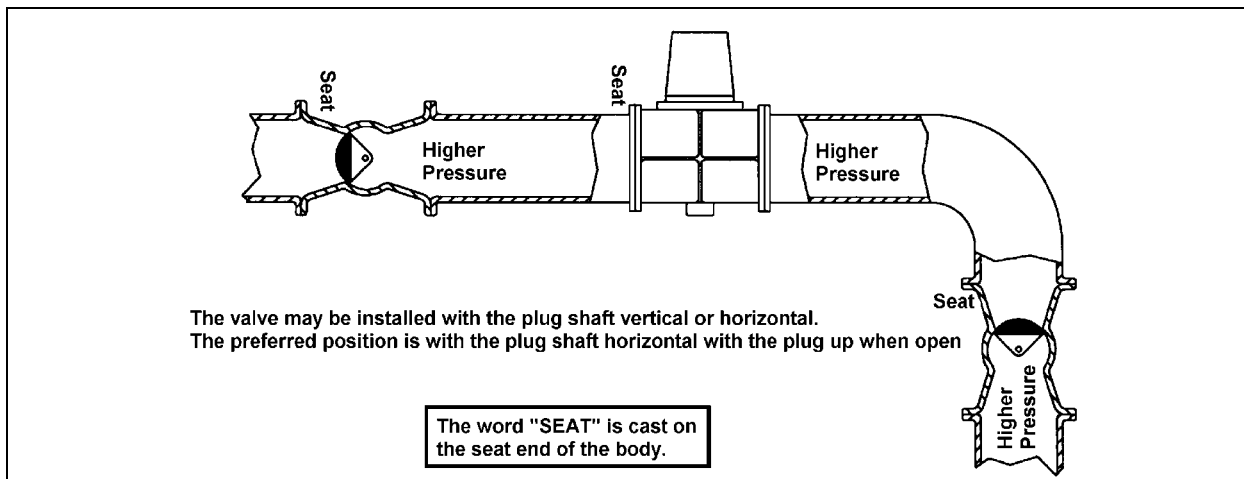

**Figure 1 — Liquids and Gases**

3. Ensure the valve and flanges are concentric to ensure proper flange sealing.
4. Tighten the flange bolts or studs in a crisscross pattern.

**Installation (continued)****Suspended Solids**

If the pipeline carries suspended solids such as paper stock of 2 percent or higher consistency, mining slurry, or raw sewage:

1. Before installation, remove foreign material such as weld spatter, oil, grease, and dirt from the valve and pipeline.
2. Install the valve as shown in Figure 2.
  - a. In HORIZONTAL pipelines, install the valve so that the plug is horizontal and rotates upward as the valve opens.
  - b. For VERTICAL pipelines, install the valve with the end marked "SEAT" at top of valve.

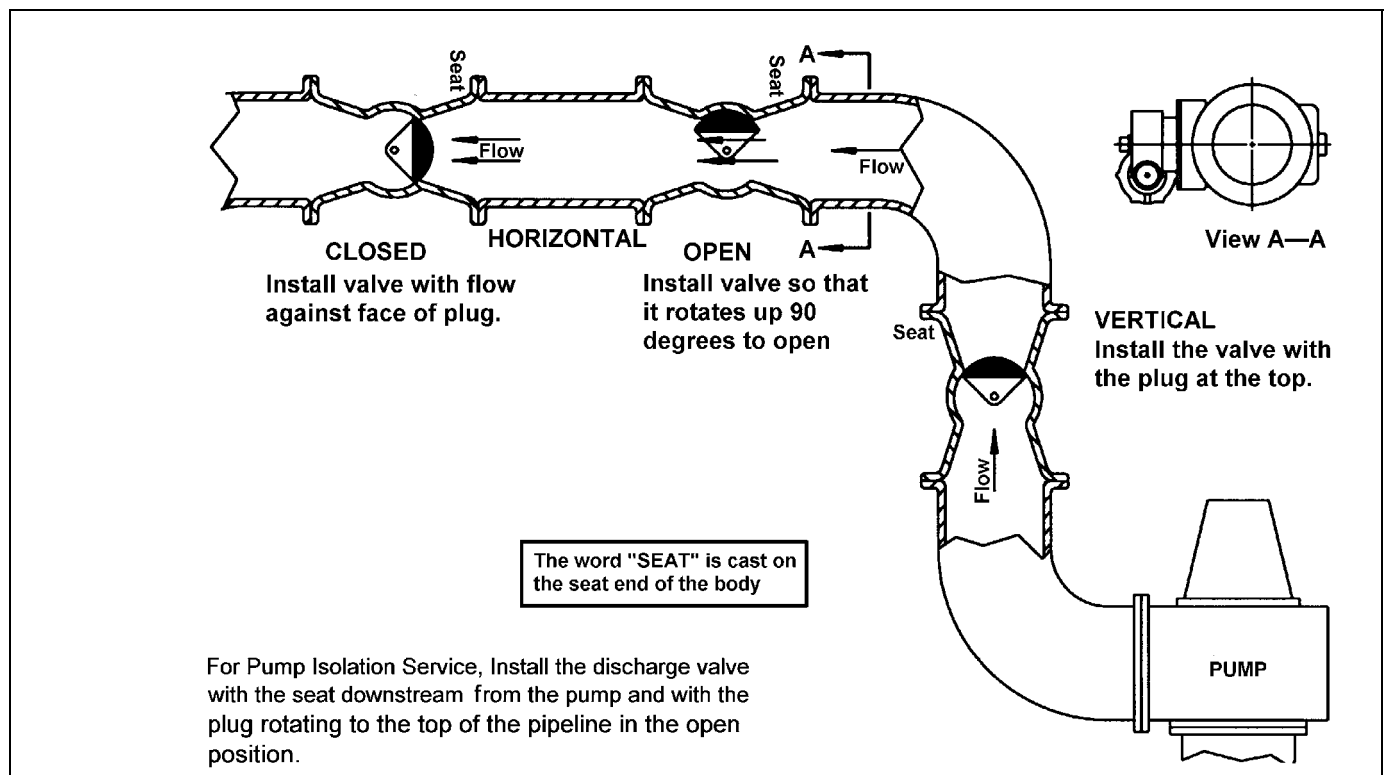

**Figure 2 — Liquids with Suspended Solids**

3. Tighten the flange bolts or studs in a crisscross pattern.
4. Ensure the valve and flanges are concentric to ensure proper flange sealing.

### Lubrication

These valves have been lubricated at the factory and require no routine maintenance lubrication. If the valve is disassembled lubricate the plug journals and felt washer as follows:

**OXYGEN SERVICE VALVES** -- Lubricate the specified valve components with Hooker Fluorolube GR-362 (no substitutes are allowed) unless valve has an aluminum actuator. Valves with aluminum actuators must be lubricated with DuPont Krytox 240-AC (no substitutes are allowed). To determine if your valve has an aluminum actuator, see the Actuator Instructions.

**APPLICATIONS OTHER THAN OXYGEN SERVICE** -- Use a flow media compatible grease. The valves have been lubricated at the factory as follows;

- Valves with CAST IRON, NI-RESIST and BRONZE plugs: Have been lubricated with a medium aluminum complex based lubricant using one of these lubricants.
  - Keystone Nevastane HT1 (**recommended**)
  - Amoco FG (alternate)
  - Mobilgrease FM 101 (alternate)
  - Petro-Canada Purity FG 2 (alternate)
  - Phillips Philube PF (alternate)
- Valves with all other plug materials: Have been lubricated with a nickel based compound using one of these lubricants.
  - Bostik Never-Seez (**recommended**)
  - Keystone No-Weld #1 (alternate)

### Stem Seal Adjustment

#### **Lever Actuator**

Tighten the lock nut on the plug stud to compress the spring slightly. The spring tension lifts the plug so the shoulder of the plug compresses the stem seal.

#### **Powered Actuator (Powerrac, G-Unit or Compact)**

Tighten the nut or screw to 5 ft-lbs.

### Closed Position

The valve must be closed with enough force to achieve shutoff while avoiding excessive torque which will cause premature plug face wear.

If the valve has a lever actuator, follow the procedure below. If the valve has other than a lever actuator, see the Instruction for that actuator.

For lever actuators, loosen the stop ring set screw, close the valve with the torque listed in Table A. While maintaining that torque, position the stop ring against the torque wrench, then tighten the set screw in the stop ring.

**Table A: Lever Actuator Seating Torques**

Valve Size	Seating Torque (ft lbs)
1/2 to 1"	9
1-1/4 & 1-1/2"	16
2"	24
2-1/2"	34
3"	52

## Disassembly



### WARNING!

**This valve is a pressure vessel. The bonnet will blow off the actuator if the bonnet bolts are removed with pressure in the valve. Pressure must be completely released before disassembly.**

1. Relieve pipeline pressure.
2. Close the valve.
3. Remove the valve from the pipeline (if desired). It is not necessary to remove the valve from the pipeline.
4. Scribe a line on the actuator housing, valve body, bonnet and plug stem to guide alignment during reassembly.
5. Remove the actuator from the valve as described in the ACTUATOR REMOVAL section of the Actuator Instructions.
6. Remove the lock nut, washer and spring from the stud.
7. Remove the bolts securing the bonnet in place, then pry the bonnet loose from the valve body.
8. Remove the plug from the valve body.
9. Pull the felt washer and seal from the bonnet.
10. Drive the bearing out of the bonnet using a hammer and pin punch.
11. Remove the bearing from the valve body. The bearing can be chiseled out, or it can be hydraulically forced out.

To hydraulically force the bearing out:

1. Fill the interior diameter of the bearing with water.
2. Pound a shaft with the same outside diameter as the lower journal of the valve plug into the bearing

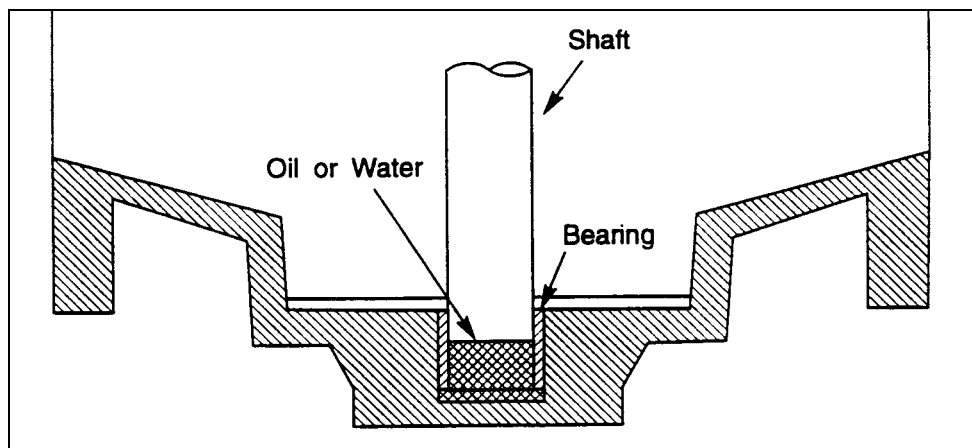

Figure 3 — Hydraulically Removing the Lower Bearing

12. Scrape all gasket material from the bonnet and body.

## Reassembly

1. Push a new lower bearing into the valve body, then lubricate the bearing as described in the "Lubrication" section.
2. Set a new gasket in the valve body.
3. Press a new bearing into the valve bonnet.
4. Push a new seal into the bonnet. See Figure 4 for correct installation.

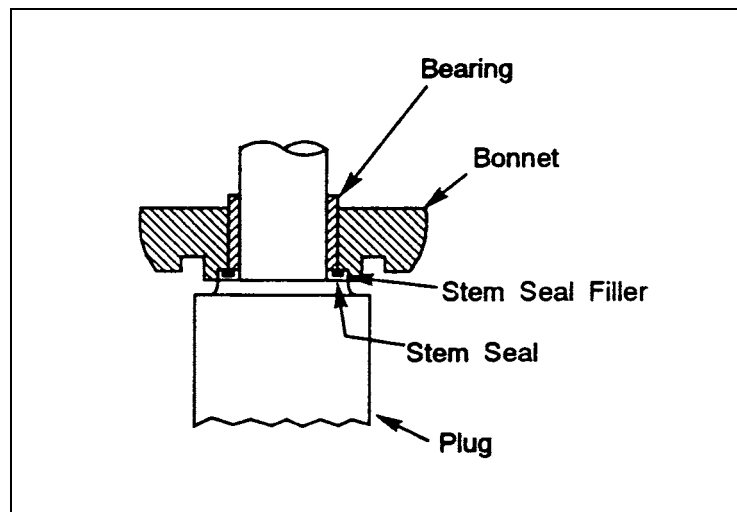

Figure 4 — Bearing and Stem Seal Arrangement

5. Lubricate the upper plug journal, then slide the bonnet down the plug until it contacts the valve body.
6. Line up the scribe marks on the plug stem, bonnet and valve body.
7. Fasten the bonnet to the body.
8. Lubricate the felt washer, then slide it down the plug stem until it fits in the counterbore in the bonnet.
9. Install the actuator as described in the Actuator Instructions.  
**Note:** If actuator mounting bolts are 1/4 inch bolts, do not exceed 100 inch pounds when tightening them.
10. Slide the spring and washer down the plug stud, and screw the lock nut onto the stud.
11. Tighten the lock nut on the plug stud to compress the spring slightly. The spring tension lifts the plug so the shoulder of the plug compresses the stem seal.
12. Adjust the closed position stop as described in the CLOSED POSITION ADJUSTMENT in these instructions.

## Removing Valve from Pipeline

To remove the entire valve assembly from the pipeline, follow these steps.



### **WARNING!**

**This valve is a pressure vessel. The bonnet will blow off the actuator if the bonnet bolts are removed with pressure in the valve. Pressure must be completely released before disassembly.**

---

1. Relieve pipeline pressure and drain portion of system where valve is located.
2. Close the valve.



### **WARNING!**

**Moving parts from accidental operation of power actuator can cause personal injury or equipment damage. Disconnect and lock out power to actuator before servicing.**

---

3. If the actuator is powered, disconnect and lock out the pneumatic, hydraulic, or electrical power to prevent accidental operation of the actuator.
4. Support the valve assembly, then remove the flange bolts.
5. Remove the valve from the pipeline.

## Field Test

Stroke the valve between the fully open and fully closed positions to verify that the valve and actuator are functioning properly.

## Emergency Operation

Operate the valve as under normal conditions, taking care to bring the plug to the position required by the particular emergency condition.

## Predicted Wear of Parts

Length of service for parts subject to wear is dependent on service conditions.

## Troubleshooting

Symptom	Possible Cause	Corrective Action
Packing Leaks.	Packing is loose.	Adjust stem seal. (See <i>"Stem Seal Adjustment"</i> section)
	Packing is worn.	Replace stem seal & stem seal filler. (See <i>"Disassembly &amp; Reassembly"</i> sections)
Valve does not close.	Object is wedged between plug and seat.	Open the valve completely to flush object. If this doesn't work, remove valve from the pipeline. (See <i>"Removing Valve from Pipeline"</i> section)
	Actuator closed position is out of adjustment.	Adjust the closed position stop as described in the Actuator instructions.
Valve leaks when closed.	Plug is worn or damaged.	Replace plug. (See <i>"Disassembly &amp; Reassembly"</i> sections)
	Rubber on plug is torn.	

## Guarantee

Products, auxiliaries and parts thereof of DeZURIK manufacture are warranted to the original purchaser for a period of twenty-four (24) months from date of shipment from factory, against defective workmanship and material, but only if properly installed, operated and serviced in accordance with DeZURIK recommendations. Repair or replacement, at our option, for items of DeZURIK manufacture will be made free of charge, (FOB) our facility with removal, transportation and installation at your cost, if proved to be defective within such time, and this is your sole remedy with respect to such products. Equipment or parts manufactured by others but furnished by DeZURIK will be repaired or replaced, but only to the extent provided in and honored by the original manufacturers warranty to DeZURIK, in each case subject to the limitations contained therein. No claim for transportation, labor or special or consequential damages or any other loss, cost or damage shall be allowed. You shall be solely responsible for determining suitability for use and in no event shall DeZURIK be liable in this respect. DeZURIK does not guarantee resistance to corrosion, erosion, abrasion or other sources of failure, nor does DeZURIK guarantee a minimum length of service. Your failure to give written notice to us of any alleged defect under this warranty within twenty (20) days of its discovery, or attempts by someone other than DeZURIK or its authorized representatives to remedy the alleged defects therein, or failure to return product or parts for repair or replacement as herein provided, or failure to install and operate said products and parts according to instructions furnished by DeZURIK, or misuse, modification, abuse or alteration of such product, accident, fire, flood or other Act of God, or failure to pay entire contract price when due shall be a waiver by you of all rights under this warranty.

The foregoing guarantee shall be null and void if, after shipment from our factory, the item is modified in any way or a component of another manufacturer, such as but not limited to, an actuator is attached to the item by anyone other than DeZURIK Factory Service personnel. All orders accepted shall be deemed accepted subject to this limited warranty, which shall be exclusive of any other or previous Warranty, and this shall be the only effective guarantee or warranty binding on DeZURIK, despite anything to the contrary contained in the purchase order or represented by any agent or employee of DeZURIK, in writing or otherwise, notwithstanding, including but not limited to implied warranties.

THE FOREGOING REPAIR AND REPLACEMENT OBLIGATIONS ARE IN LIEU OF ALL OTHER WARRANTIES, OBLIGATIONS AND LIABILITIES, INCLUDING ALL WARRANTIES OF FITNESS FOR A PARTICULAR PURPOSE OR OF MERCHANTABILITY OR OTHERWISE, EXPRESSED OR IMPLIED IN FACT OR BY LAW, AND STATE DEZURIK'S ENTIRE AND EXCLUSIVE LIABILITY AND YOUR EXCLUSIVE REMEDY FOR ANY CLAIM IN CONNECTION WITH THE SALE AND FURNISHING OF SERVICES, GOODS OR PARTS, THEIR DESIGN, SUITABILITY FOR USE, INSTALLATION OR OPERATIONS.

## Limitation of liability

LIMITATION OF LIABILITY: IN NO EVENT SHALL DEZURIK BE LIABLE FOR ANY DIRECT, INDIRECT, SPECIAL OR CONSEQUENTIAL DAMAGES WHATSOEVER, AND DEZURIK'S LIABILITY, UNDER NO CIRCUMSTANCES, WILL EXCEED THE CONTRACT PRICE FOR THE GOODS AND/OR SERVICES FOR WHICH LIABILITY IS CLAIMED. ANY ACTION BY YOU FOR BREACH OF CONTRACT MUST BE COMMENCED WITHIN 12 MONTHS AFTER THE DATE OF SALE.

## Sales and Service

For information about our worldwide locations, approvals, certifications and local representative:

Web site: [www.dezurik.com](http://www.dezurik.com) E-Mail: [info@dezurik.com](mailto:info@dezurik.com)



250 Riverside Ave. N., Sartell, MN 56377 • Phone: 320-259-2000 • Fax: 320-259-2227

*DeZURIK reserves the right to incorporate our latest design and material changes without notice or obligation. Design features, materials of construction and dimensional data, as described in this manual, are provided for your information only and should not be relied upon unless confirmed in writing by DeZURIK Certified drawings are available upon request.*