

# SARTELL Valves, Inc.

Accessories For:

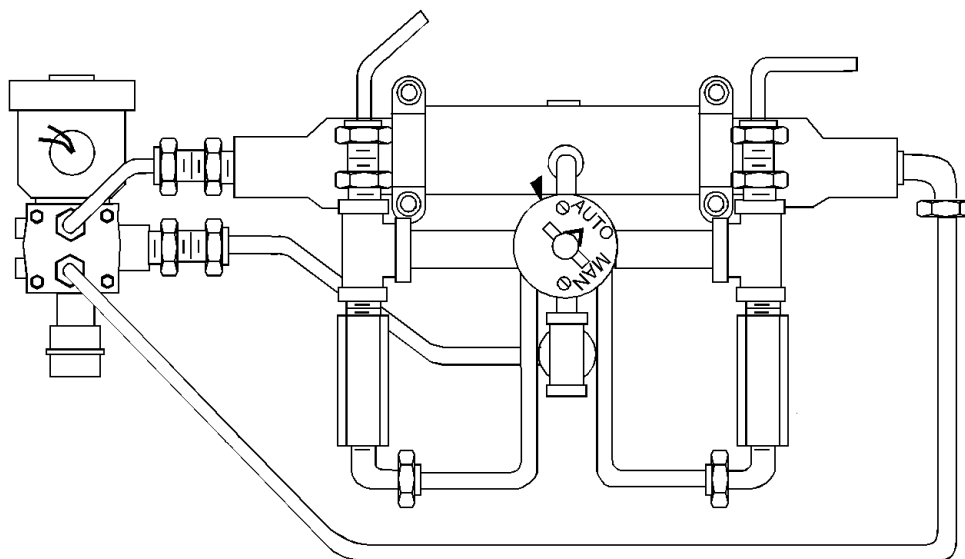

## EP PUMP CHECK ACCESSORIES



**INSTRUCTIONS**

These instructions provide information about the EP Pump Check Accessories. They are for use by personnel who are responsible for installation, operation and maintenance of EP Pump Check Accessories.

**SAFETY  
MESSAGES**

All safety messages in the instructions are flagged with an exclamation symbol and the word Caution, Warning or Danger. These messages indicate procedures that must be followed exactly to avoid equipment damage, personal injury or death.

Safety label(s) on the product indicate hazards that can cause equipment damage, personal injury or death. If a safety label becomes difficult to see or read, or if a label has been removed, please contact SARTELL Valves, Inc. for replacement label(s).



**WARNING**

**Personnel involved in the installation or maintenance of valves should be constantly alert to potential emission of pipeline material and take appropriate safety precautions. Always wear suitable protection when dealing with hazardous pipeline materials. Handle valves which have been removed from service with the assumption of pipeline material within the valve.**

---

**INSPECTION**

Your EP Pump Check Accessories have been packaged to provide protection during shipment, however, it can be damaged in transport. Carefully inspect the unit for damage upon arrival and file a claim with the carrier if damage is apparent.

**PARTS**

Recommended spare parts are listed on the assembly drawing. These parts should be stocked to minimize downtime.

Order parts from your local SARTELL Valves, Inc. sales representative, or directly from SARTELL Valves, Inc. When ordering parts, please include the 7-digit part number, the part name, the assembly drawing number, the balloon number and the quantity stated on the assembly drawing.

**SARTELL  
VALVES, INC.  
SERVICE**

SARTELL Valves, Inc. service personnel are available to install, maintain and repair all SARTELL Valves, Inc. products. SARTELL Valves, Inc. also offers customized training programs and consultation services.

For more information, contact your local SARTELL Valves, Inc. sales representative or visit our website at [www.sartellvalves.com](http://www.sartellvalves.com).

<b>TABLE OF CONTENTS</b>	Description ----- 1 Pump Check Installation <i>Suspended Solids</i> ----- 1 <i>Liquids and Gases</i> ----- 3 Electrical ----- 3 Piping Connections <i>Hydraulic</i> ----- 3 <i>Pneumatic</i> ----- 4 Operation <i>Automatic Open Pneumatic Pump Check Valve FIG 390 and 390, R</i> 4 <i>Automatic Open Hydraulic Pump Check Valve FIG 391 and 391, R</i> - 5 <i>Automatic Close</i> ----- 6 <i>Close On Power Failure</i> - - - - - 7 <i>Emergency Shutdown</i> - - - - - 7 <i>Actuation Without Electrical Power</i> - - - - - 7 <i>Actuation Without Cylinder Pressure</i> - - - - - 7 <i>Rapid Close Option</i> - - - - - 7 Speed Adjustments <i>Opening Speed</i> - - - - - 8 <i>Closing Speed</i> - - - - - 8 <i>Rapid Closing Speed</i> - - - - - 9 Switches <i>Switch Arrangement</i> - - - - - 9 <i>Switch Adjustment</i> - - - - - 9 <i>Switch Ratings</i> - - - - - 9
--------------------------	---

**DESCRIPTION**      The SARTELL Valves, Inc. Pump Check valve can serve the purpose of both a check valve and isolation valve in your system. Its unique design reduces the possibility of water hammer by controlling valve opening and closing speeds, thus the operation does not cause pressure surges in either direction.

The Pump Check valve is normally actuated by an electrical signal from a pressure switch, either remote or local, while speed control metering valves control the speed of actuation.

**PUMP CHECK INSTALLATION**      ***Suspended Solids***  
 It is critical that valves in these environments are properly installed so that sediments do not pack the valve body.

IN HORIZONTAL PIPELINES:

1. Install the valve so that the flow is against the face of plug when closed.
2. Position the valve so that the plug rotates 90° to the top to open.

In VERTICAL pipelines:

1. Install the valve with the plug at the top.

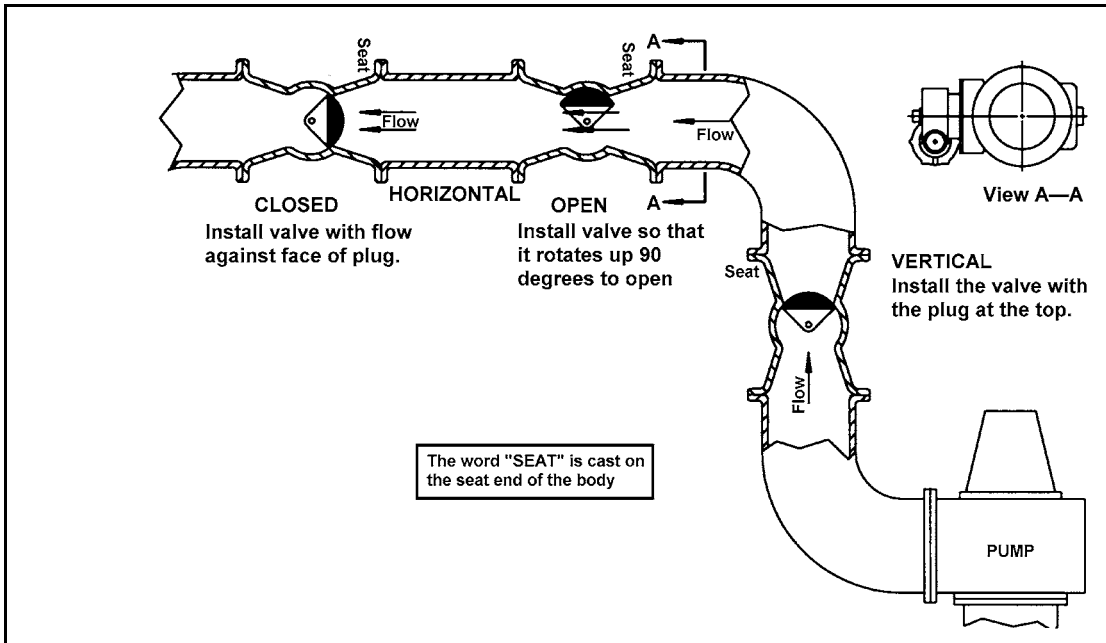
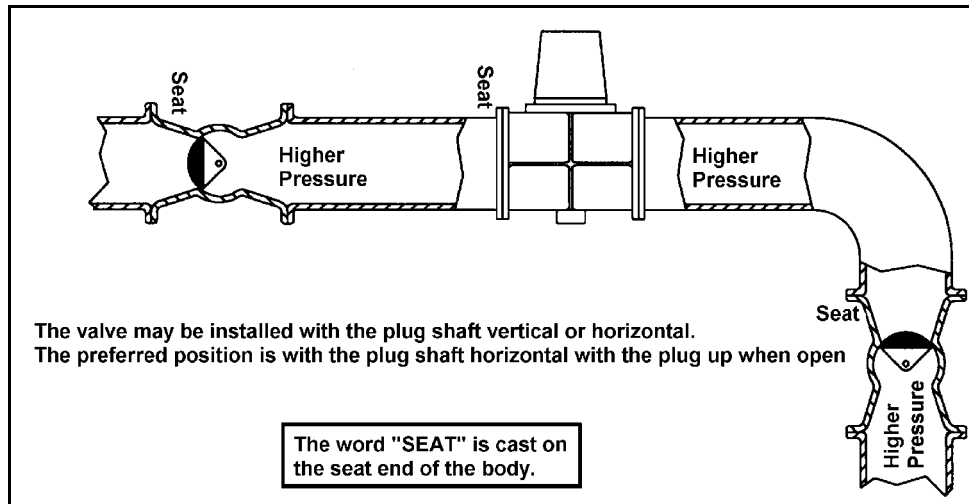

**Figure 1—Liquids with Suspended Solids**

**Pump Check  
 Installation  
 (Continued)**

**Liquids and Gases**

For liquids and gases, install the valve with the higher pressure opposite the seat.  
 In horizontal pipelines, install valve so the plug is horizontal and rotates upward to open.



**Figure 2—Liquids and Gases**

**ELECTRICAL**

See wiring diagram, Figure 3:

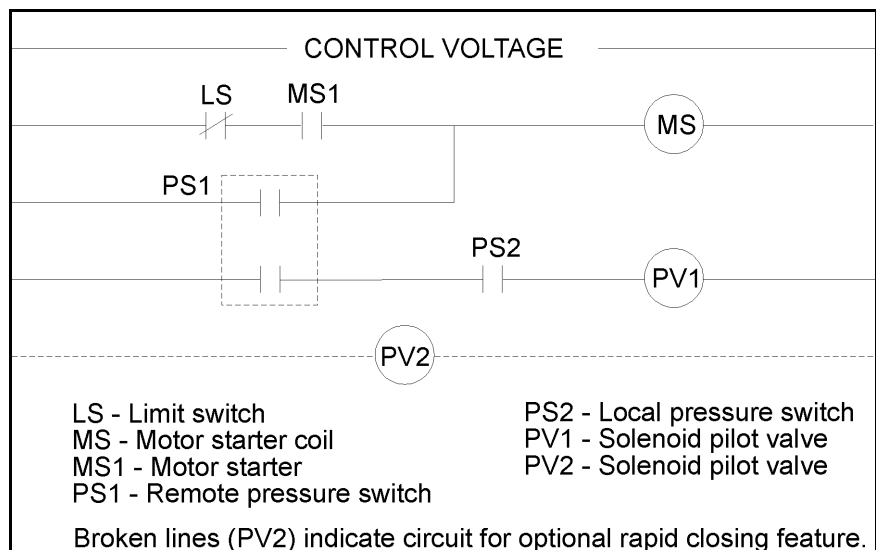

**Figure 3—Wiring Diagram**

**PIPING  
 CONNECTIONS**

**Hydraulic**

1. Connect 50–100 psi clean liquid media to the fitting in the port of the 4-way manual valve.

*Note:* It is strongly recommended that a screen filter or strainer (may be purchased as an accessory item from SARTELL Valves, Inc.) be installed in the supply line to keep dirt particles in the media from entering the pump check system.

**Pneumatic**

1. Connect 50–100 psi clean, dry air to remaining port of the 4-way manual valve.

*Note:* It is strongly recommended that a filter (may be purchased as an accessory item from SARTELL Valves, Inc.) be installed in the supply line to keep dirt particles in the air from entering the pump check system.

**OPERATION**

The SARTELL Valves, Inc. Pump Check valve can be connected to provide either AUTOMATIC OPEN or AUTOMATIC CLOSE operation, depending upon the customer's requirements. Each of the modes is described below.

**Automatic Open Pneumatic Pump Check Valve FIG 390 and 390, R**

In the automatic open mode, the pump check valve opens when pressure or liquid levels decrease.

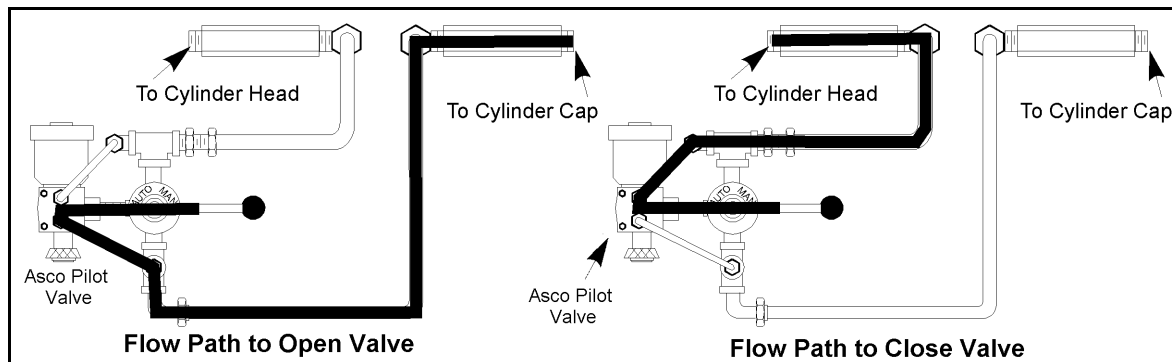

**Figure 4—Flow Path: Automatic Open Pneumatic Pump Check Valve**

Automatic open operation of the PNEUMATIC pump check valve follows this sequence:

- a. When the system pressure or liquid level decreases, contacts in the remote pressure switch close and energize the motor starter coil.
- b. The motor starter coil closes the contacts in the motor starter which starts the pump motor.
- c. The pumping pressure closes the local pressure switch contacts.
- d. The local pressure switch energizes the ASCO pilot valve which directs air through the pilot valve to the cylinder.

*Note:* See Figure 3 on page 3 for Wiring Diagram.

**Operation**  
**(Continued)**

**Automatic Open Hydraulic Pump Check Valve FIG 391 and 391, R**

In the automatic open mode, the pump check valve opens when pressure or liquid levels decrease.

Automatic open operation of the HYDRAULIC pump check valve follows this sequence:

- a. When the system pressure or liquid level decreases, contacts in the remote pressure switch close and energize the motor starter coil.
- b. The motor starter coil closes the contacts in the motor starter which starts the pump motor.
- c. The pumping pressure closes the local pressure switch contacts.
- d. The local pressure switch energizes the ASCO pilot valve.
- e. The pilot valve directs hydraulic fluid to one side of the pilot valve.
- f. The spool inside the pilot valve moves and opens a flow path from the supply to the cylinder.

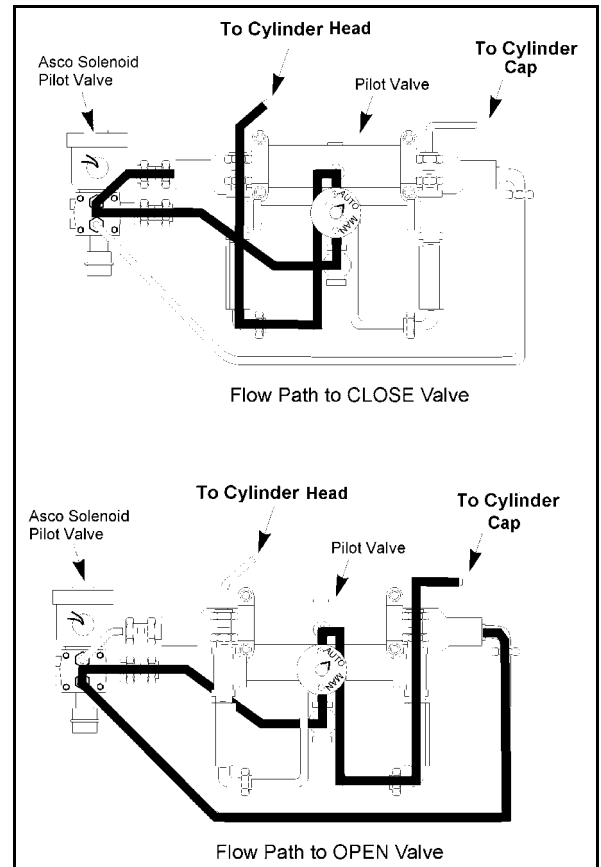

**Figure 5—Flow Path: Automatic Open Hydraulic Pump Check Valve**

*Note:* See Figure 3 on page 3 for Wiring Diagram.

**Operation**     **Automatic Close**  
**(Continued)**

In the automatic close mode, the pump check valve closes when pressure or liquid level reaches a pre-set level.

- a. When pressure or liquid level requirements are met, the remote pressure switch contacts open and de-energize the ASCO pilot valve.
- b. This causes the pump check valve to begin closing at the pre-set speed.
- c. The contacts on the limit switch then open at a pre-set point and de-energize the motor starter coil, opening the motor starter contacts and stopping the pump.
- d. The valve continues to close as the pump slows down, completely shutting just as the forward flow from the pump stops.

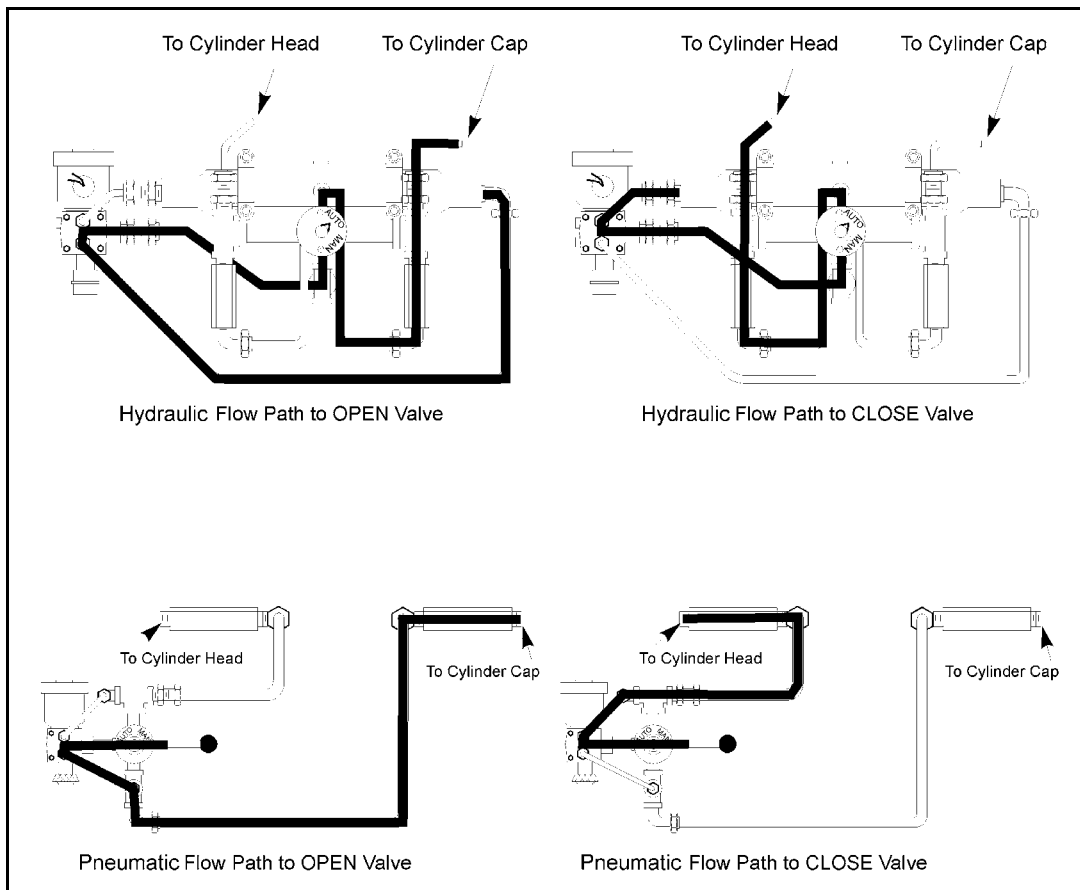

**Figure 7—Automatic Close Flow Paths**

**Operation**  
**(Continued)**

**Close On Power Failure**

In case of power failure, the pump motor stops and all coils are de-energized. The valve will then move to its fully closed position.

**Emergency Shutdown**



**CAUTION**

**Pump backspin may occur when the emergency stop is used. Pump backspin is the result of backflow, which may occur in the pipeline when the pump motor is de-energized and the valve is not fully closed.**

---

Pressing the emergency button (supplied by the customer) interrupts the power supply to the pump motor and the valve. This de-energizes the ASCO pilot valve and causes the valve to move to its fully closed position.

**Actuation Without Electrical Power**

The pump check valve can be actuated without electrical power by using the manual override on the ASCO pilot valve.

To use the manual override:

1. Pull the red knob out.
2. Turn knob 30 degrees.
3. Release the knob.

*Note:* The knob should go in farther than it was before you pulled it out.

To return the pilot valve to automatic operation:

1. Pull the red knob out.
2. Turn knob 30 degrees.
3. Release the knob.

*Note:* To control the pilot valve electrically, the knob must be in the automatic position.

**Actuation Without Cylinder Pressure**

The SARTELL Valves, Inc. Pump Check valve can be manually actuated by setting the 4-way valve to the Manual (MAN) position, then turning the wrenching square which is located on the actuator just under the switch housing.

*Note:* Clockwise rotation closes the valve.

**Rapid Close Option**

The rapid close option allows the pump check valve to close rapidly by allowing an additional exhaust port to open.

This option includes an ASCO pilot valve and a speed control.

**SPEED  
 ADJUSTMENTS**

**Opening Speed**

Opening speed is controlled by a speed control located in the piping connected to the cylinder head. To set the opening speed, adjust the screw in the speed control until you get the desired opening speed.

**Closing Speed**

Closing speed is controlled by a speed control located in the piping connected to the cylinder cap. To set the closing speed, adjust the screw in the speed control until you get the desired closing speed.

*Note:* These adjustments are written for a pump check valve that is piped to provide the AUTOMATIC CLOSE mode of operation. If your pump check is piped for AUTOMATIC OPEN, exchange the terms “Cylinder Head” and “Cylinder Cap” with each other.

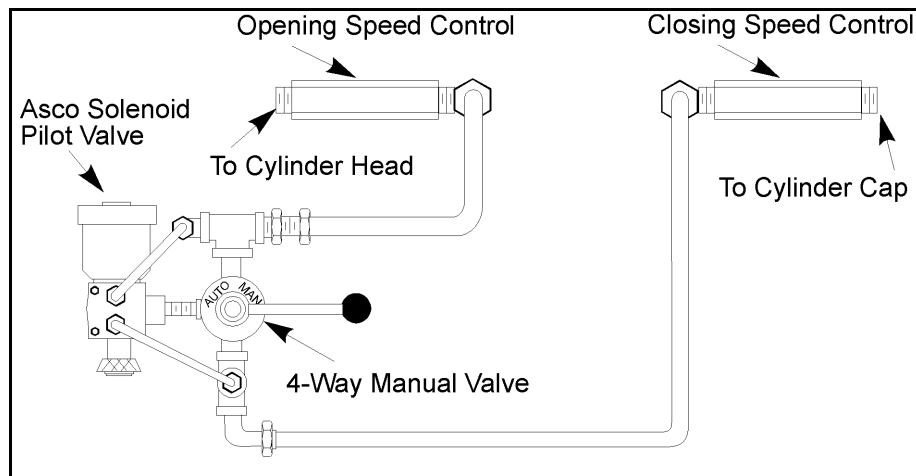

**Figure 8—Pneumatic Pump Check Adjustments**

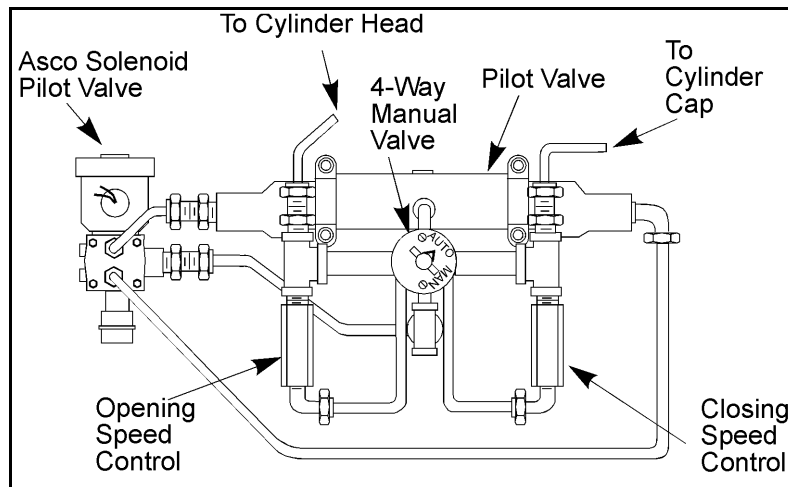

**Figure 9—Hydraulic Pump Check Adjustments**

**Adjustments**  
*(Continued)*

***Rapid Closing Speed***

Rapid closing speed is controlled by a speed control located in the cylinder cap port. The rapid closing speed must be adjusted after the normal closing speed has been adjusted, and while the rapid-closing pilot valve is de-energized. Adjust the screw in the speed control until the desired rapid closing speed is obtained.

**SWITCHES**

The limit switch, open position switch and auxiliary switches are all contained in the switch housing.

***Switch Arrangement***

The switches are arranged so the limit switch is the top switch, the open position switch is next, followed by the auxiliary switches.

***Switch Adjustment***

Each switch is actuated by a rotating cam.

To adjust a top switch:

1. Push the top cam down.
2. Rotate the cam to the new position.
3. Release the cam so it engages into the new position on the spline.

To adjust a bottom switch:

1. Lift the bottom cam up.
2. Rotate the cam to the new position.
3. Release the cam so it engages into the new position on the spline.

Each cam may be fine-tuned between spline positions by turning the set screw on the cam with a 1/16" hex driver.

*Note:* The set screw adjustment is limited to no more than one full turn.

***Switch Rating***

10 amps, 120, 240 VAC

1/3 HP 125, 250, 270 VAC

1/2 amp, 120 VDC

1/4 amp, 250 VDC