

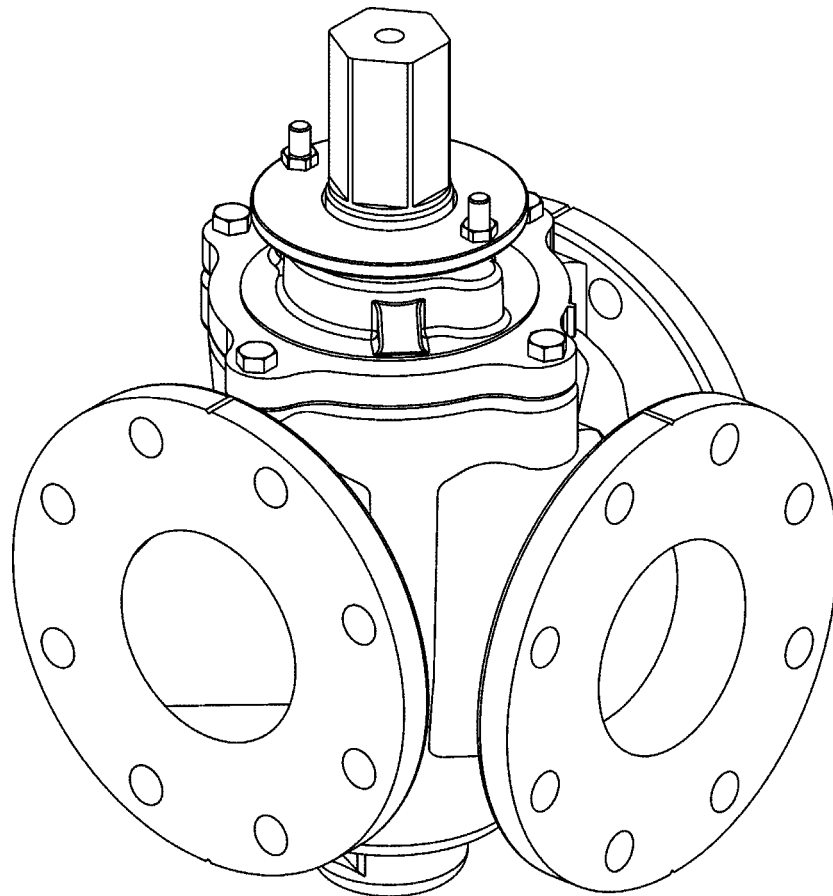

2--16" PTW & PFW TAPERED PLUG VALVES



Instruction **DS10188**

July 2008

Instructions

These instructions provide information about Tapered Plug Valves. They are for use by personnel who are responsible for installation, operation and maintenance of Tapered Plug Valves.

Safety Messages

All safety messages in the instructions are flagged with an exclamation symbol and the word Caution, Warning or Danger. These messages indicate procedures that must be followed exactly to avoid equipment damage, personal injury or death. Safety label(s) on the product indicate hazards that can cause equipment damage, personal injury or death. If a safety label becomes difficult to see or read, or if a label has been removed, please contact SARTELL Valves & Controls for replacement label(s).



WARNING!

Personnel involved in the installation or maintenance of valves should be constantly alert to potential emission of pipeline material and take appropriate safety precautions. Always wear suitable protection when dealing with hazardous pipeline materials. Handle valves, which have been removed from service with suitable protection for any potential pipeline material in the valve.

Inspection

Your Tapered Plug Valve has been packaged to provide protection during shipment, however, it can be damaged in transport. Carefully inspect the unit for damage upon arrival and file a claim with the carrier if damage is apparent.

Parts

Recommended spare parts are listed on the assembly drawing. These parts should be stocked to minimize downtime.

Order parts from your local SARTELL Valves & Controls sales representative, or directly from SARTELL Valves & Controls. When ordering parts, please include the 7-digit part number and 4-digit revision number (example: **9999999R000**) located on the data plate attached to the valve assembly. Also include the part name, the assembly drawing number, the balloon number and the quantity stated on the assembly drawing.

SARTELL Valves & Controls Service

SARTELL Valves & Controls service personnel are available to install, maintain and repair all SARTELL Valves & Controls products. SARTELL Valves & Controls also offers customized training programs and consultation services.

For more information, contact your local SARTELL Valves & Controls sales representative or visit our website at www.sartellvalves.com.

Table of Contents

Description - - - - -	4
Required Tools - - - - -	4
Installation - - - - -	4
Flow Direction - - - - -	4
Lubrication	
<i>Packing</i> - - - - -	4
<i>Plug Journals and Lubrication</i> - - - - -	5
Packing Adjustment - - - - -	6
Plug Clearance Adjustment - - - - -	6
Packing Replacement - - - - -	6
Disassembly - - - - -	8
Reassembly - - - - -	9
Removing Valve from Pipeline - - - - -	10
Field Test - - - - -	10
Emergency Operation - - - - -	10
Predicted Wear of Parts - - - - -	10
Troubleshooting - - - - -	11

Description

The 3-Way (PTW) and 4-Way (PFW) Tapered Plug valves are available with material, actuator and accessory options to meet a wide range of application requirements.

Three plug styles are offered to provide flow paths with 90 and 360 degree plug rotation. Each different flow path arrangement has a unique number called a Combination Number. See the Product Bulletin for these valves for a complete description of the Combination Numbers.

If an actuator other than a SARTELL Valves & Controls is to be mounted, the actuator must be capable of maintaining the valve plug position with flow in the pipeline.



WARNING!

This valve is a pressure vessel. Failure to release pipeline pressure may result in personal injury and/or flow system damage. Completely release pipeline pressure before removing the actuator from the valve or removing the valve from the pipeline.

Required Tools

This valve is assembled using only SAE fasteners. To service this valve, you should have a full set of combination wrenches, Allen wrenches, a large flat tipped screwdriver, a flat pry bar, a pin punch and a dead blow hammer.

Note: You may want to machine a shaft to aid you in removing the lower bearing from the body. See "Disassembly" section.

Installation

This Instruction Manual covers the installation requirements of the valve only. For actuator or accessory installation information, see the Instruction Manual for that component.

Flow Direction

It is recommended that the valve be installed so pipeline pressure will push the plug into the seat(s) of the port(s) being sealed.

Lubrication

This valve does not require routine maintenance lubrication. If the valve is disassembled, lubricate the packing and plug journals as follows:

Packing

Packing lubrication requirements are dependent upon the packing material.

- PTFE PACKING: Requires no lubrication.
- **ALL PACKING OTHER THAN PTFE:** Apply a light coat to the inside and outside diameters of the packing rings using one of these lubricants.
 - Keystone Nevastane HT1 (**recommended**)
 - Phillips Philube PF (alternate)
 - Mobilgrease FM 101 (alternate)
 - Amoco FG (alternate)

Note: Ensure lubricant is compatible with flow media.

Lubrication *(Continued)*

Plug Journals and Lubrication

Plug journal lubrication is dependent upon the materials used in construction of the valve.

- CAST IRON, NI-RESIST, BRONZE AND ACID BRONZE VALVES: Lubricate the journals on the plug using one of these lubricants.
 - Keystone Nevastane HT1 (**recommended**)
 - Phillips Philube PF (alternate)
 - Mobilgrease FM 101 (alternate)
 - Amoco FG (alternate)
- ALL VALVES EXCEPT CAST IRON, NI-RESIST, BRONZE, & ACID BRONZE: Coat the journals on the plug with a light coat using one of these lubricants.
 - Dow Corning Molykote G Rapid paste (**recommended**)
 - Shell Retinax AM (alternate)
 - Shell Lithall MDS (alternate)

Then lubricate with a mixture of powdered graphite and one of these lubricants.

- Standard Oil #140 Gear Lube (**recommended**)
 - Mobil Mobilgear 634 (alternate)
 - Shell Omala 460 (alternate)
 - Texaco Meropa 460 (alternate)
 - Amoco MP (alternate)
- HARD RUBBER LINED VALVES: Lubricate the journals on the plug using one of these lubricants.
 - Dow Corning Molykote #44 (**recommended**)
 - Magnalube G (alternate)
 - Texaco Molytex E.P. Grade 2 (alternate)

Packing Adjustment

All standard tapered plug valves feature adjustable stem seal packing. If a stem seal packing leak should occur, tighten the gland nuts evenly just until the leakage stops.

Note: Do Not continue tightening after leakage stops. If packing leakage cannot be stopped by tightening the gland nuts, the packing must be replaced.

Plug Clearance Adjustment

On valves not utilizing a Lift, Turn, Reseat actuator, the seat/plug clearance can be adjusted by removing the locknut and wrenching square from the top of the valve, then turning the plug adjusting nut to change the seat/plug clearance. Turning the nut clockwise will increase the clearance between the seat and plug; turning the nut counterclockwise will decrease the clearance. Recommended seat plug clearance is .030" for paper stock and .010" for all other applications.

Packing Replacement

Follow these steps to replace the packing with the actuator removed:

1. Discontinue pipeline flow and relieve pipeline pressure.
2. Scribe the actuator and valve bonnet for alignment when reassembling.



WARNING!

Moving parts from accidental operation of power actuator can cause personal injury or equipment damage. Disconnect and lock out power to actuator before servicing.

3. If the actuator is powered, disconnect and lock out the pneumatic, hydraulic, or electrical power to prevent accidental operation of the actuator.

Packing Replacement *(Continued)*



WARNING!

When a tapered plug valve is mounted in a vertical pipeline—or mounted in a horizontal pipeline with the plug stem horizontal—gravity can cause the plug to swing to a lower position in the valve body when the actuator is removed. Place the plug in the lowest position before removing the actuator.

4. Remove the actuator from the valve. See Actuator Instructions.
5. Remove the actuator adaptor (when used) from the valve.
6. Remove the packing gland nuts, then slide the packing gland off the valve shaft.
7. Pull the packing out of the bonnet.
8. Lubricate the new packing, then install it one ring at a time in the sequence shown in Figure 1.

Packing Replacement *(Continued)*

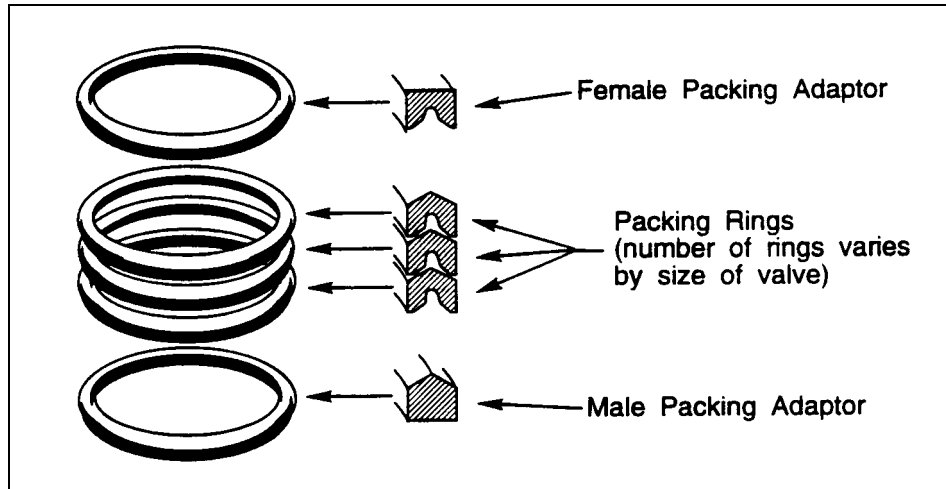

Figure 1—Correct Packing Installation Sequence

9. Slide the packing gland down the valve shaft and over the studs.
10. Turn the packing gland nuts onto the studs until they touch the packing gland, then one more turn.
Note: This is a preliminary adjustment, it will be necessary to adjust the packing gland nuts after the valve is pressurized.
11. Fasten the adaptor (when used) to the valve, lining up the scribe marks made during disassembly.
12. Install the actuator as described in the Actuator Instructions.
13. If the actuator is a powered actuator, reconnect power to the actuator.

Disassembly

Follow these steps to disassemble valve:



WARNING!

This valve is a pressure vessel. The bonnet will blow off the actuator if the bonnet bolts are removed with pressure in the valve. Pressure must be completely released before disassembly.

1. Relieve pipeline pressure.



WARNING!

Moving parts from accidental operation of power actuator can cause personal injury or equipment damage. Disconnect and lock out power to actuator before servicing.

2. If the actuator is powered, disconnect and lock out the pneumatic, hydraulic, or electrical power to prevent accidental operation of the actuator.
3. Scribe a line on the actuator, body & bonnet for alignment when reassembling.
4. Remove the valve from the pipeline (if desired).

Note: The valve can be disassembled while still in the pipeline.



WARNING!

When a tapered plug valve is mounted in a vertical pipeline—or mounted in a horizontal pipeline with the plug stem horizontal—gravity can cause the plug to swing to a lower position in the valve body when the actuator is removed. Place the plug in the lowest position before removing the actuator.

5. Remove actuator from valve—see Actuator Instructions.
6. Note the orientation of the plug in relationship to the valve ports. (See Figure 2 for markings.)

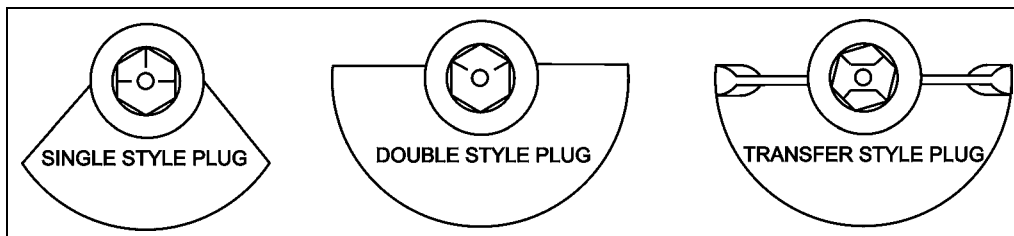

Figure 2—Plug Stem Markings

7. Remove the bolts that hold the bonnet in place, then pry the bonnet loose from the valve body.
8. Remove the plug from the valve body.
9. Remove the gland nuts and gland from the bonnet.
10. Remove the packing from the bonnet.

Disassembly (Continued)

11. Reaching through the packing chamber in the bonnet, drive the upper bearing out of the bonnet using a hammer and pin punch.
12. Remove the lower bearing from the valve body.

Note: The bearing can be chiseled out; or, it can be hydraulically forced out. See Figure 3.

To hydraulically force the bearing out:

1. Fill the interior diameter of the bearing with water.
2. Pound a shaft with the same outside diameter as the lower journal of the valve plug into the bearing

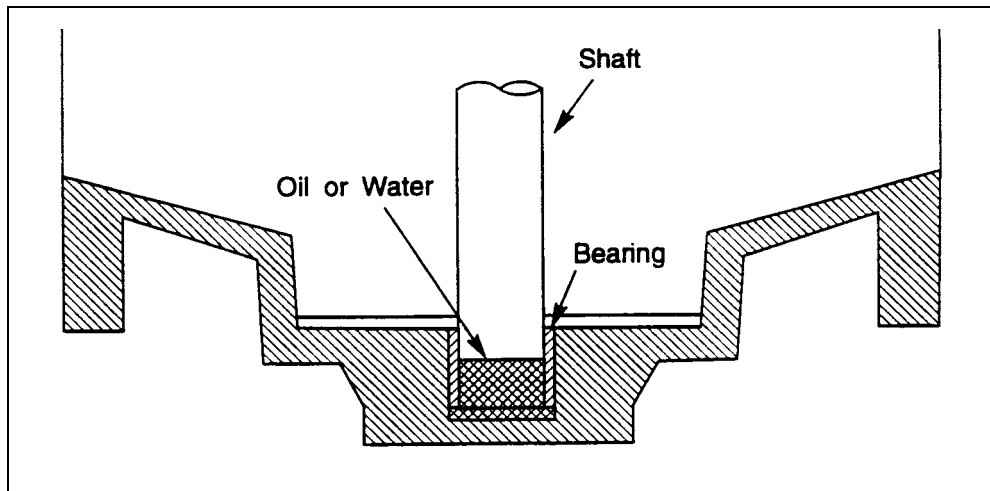

Figure 3—Hydraulically Removing the Lower Bearing

Reassembly

1. Push a new lower bearing into the valve body, then lubricate the bearing as described in the LUBRICATION section of these instructions.
2. Place the plug into the valve body so the lower journal slides into the bearing. Turn the plug so it is in position noted during disassembly.
3. Set a new gasket in the body.
4. Push a new bearing into the bonnet, then lubricate the bearing. See LUBRICATION section of these instructions
5. Place bonnet on valve, align scribe marks, then fasten bonnet in place.
6. Lubricate the new packing, then install it one ring at a time. See Figure 1.
7. Slide the packing gland down the valve shaft and over the studs.
8. Turn the packing gland nuts onto the studs until they contact the packing gland, then one additional turn.

Note: This is a preliminary adjustment, it will be necessary to adjust the packing gland nuts after the valve is pressurized. See PACKING ADJUSTMENTS in these instructions.

9. Install the actuator—see Actuator Instructions.

Reassembly *(Continued)*

10. If the actuator is a powered actuator, reconnect power to the actuator.
11. After pipeline flow is restored, check the packing for leakage.

Note: If packing leaks, tighten the packing gland nuts only enough to stop the leak. Over tightening the packing will cause premature packing failure and higher valve operating torque.

Removing Valve from Pipeline

To remove the entire valve assembly from the pipeline, follow these steps.



WARNING!

This valve is a pressure vessel. The bonnet will blow off the actuator if the bonnet bolts are removed with pressure in the valve. Pressure must be completely released before disassembly.

1. Relieve pipeline pressure and drain portion of system where valve is located.



WARNING!

Moving parts from accidental operation of power actuator can cause personal injury or equipment damage. Disconnect and lock out power to actuator before servicing.

2. If the actuator is powered, disconnect and lock out the pneumatic, hydraulic, or electrical power to prevent accidental operation of the actuator.
3. Support the valve assembly, then remove the flange bolts.
4. Remove the valve from the pipeline.

Field Test

Stroke the valve between ports to verify that the valve and actuator are functioning properly.

Emergency Operation

Operate the valve as under normal conditions, taking care to bring the plug to the position required by the particular emergency condition.

Predicted Wear of Parts

Length of service for parts subject to wear is dependent on service conditions.

Troubleshooting

Symptom	Possible Cause	Corrective Action
Packing Leaks.	Packing is loose.	Adjust Packing.
	Packing is worn.	Replace Packing.
Valve does not close.	Object is wedged between plug and seat.	Open the valve completely to flush object. If this doesn't work, remove valve from the pipeline.
	Actuator closed position is out of adjustment.	Adjust the closed position stop. See Actuator Instructions.
Valve leaks when closed.	Plug is worn or damaged.	Replace plug.
	Rubber on plug is torn.	

Guarantee

Products, auxiliaries and parts thereof of Sartell Valves, Inc. manufacture are warranted to the original purchaser for a period of twenty-four (24) months from date of shipment from factory, against defective workmanship and material, but only if properly installed, operated and serviced in accordance with Sartell Valves, Inc. recommendations. Repair or replacement, at our option, for items of Sartell Valves, Inc. manufacture will be made free of charge, (FOB) our facility with removal, transportation and installation at your cost, if proved to be defective within such time, and this is your sole remedy with respect to such products. Equipment or parts manufactured by others but furnished by Sartell Valves, Inc. will be repaired or replaced, but only to the extent provided in and honored by the original manufacturers warranty to Sartell Valves, Inc., in each case subject to the limitations contained therein. No claim for transportation, labor or special or consequential damages or any other loss, cost or damage shall be allowed. You shall be solely responsible for determining suitability for use and in no event shall Sartell Valves, Inc. be liable in this respect. Sartell Valves, Inc. does not guarantee resistance to corrosion, erosion, abrasion or other sources of failure, nor does Sartell Valves, Inc. guarantee a minimum length of service. Your failure to give written notice to us of any alleged defect under this warranty within twenty (20) days of its discovery, or attempts by someone other than Sartell Valves, Inc. or its authorized representatives to remedy the alleged defects therein, or failure to return product or parts for repair or replacement as herein provided, or failure to install and operate said products and parts according to instructions furnished by Sartell Valves, Inc., or misuse, modification, abuse or alteration of such product, accident, fire, flood or other Act of God, or failure to pay entire contract price when due shall be a waiver by you of all rights under this warranty.

The foregoing guarantee shall be null and void if, after shipment from our factory, the item is modified in any way or a component of another manufacturer, such as but not limited to, an actuator is attached to the item by anyone other than Sartell Valves, Inc. Factory Service personnel. All orders accepted shall be deemed accepted subject to this limited warranty, which shall be exclusive of any other or previous Warranty, and this shall be the only effective guarantee or warranty binding on Sartell Valves, Inc., despite anything to the contrary contained in the purchase order or represented by any agent or employee of Sartell Valves, Inc., in writing or otherwise, notwithstanding, including but not limited to implied warranties.

THE FOREGOING REPAIR AND REPLACEMENT OBLIGATIONS ARE IN LIEU OF ALL OTHER WARRANTIES, OBLIGATIONS AND LIABILITIES, INCLUDING ALL WARRANTIES OF FITNESS FOR A PARTICULAR PURPOSE OR OF MERCHANTABILITY OR OTHERWISE, EXPRESSED OR IMPLIED IN FACT OR BY LAW, AND STATE SARTELL VALVES, INC.'S ENTIRE AND EXCLUSIVE LIABILITY AND YOUR EXCLUSIVE REMEDY FOR ANY CLAIM IN CONNECTION WITH THE SALE AND FURNISHING OF SERVICES, GOODS OR PARTS, THEIR DESIGN, SUITABILITY FOR USE, INSTALLATION OR OPERATIONS.

Limitation of liability

LIMITATION OF LIABILITY: IN NO EVENT SHALL SARTELL VALVES, INC. BE LIABLE FOR ANY DIRECT, INDIRECT, SPECIAL OR CONSEQUENTIAL DAMAGES WHATSOEVER, AND SARTELL VALVES, INC.'S LIABILITY, UNDER NO CIRCUMSTANCES, WILL EXCEED THE CONTRACT PRICE FOR THE GOODS AND/OR SERVICES FOR WHICH LIABILITY IS CLAIMED. ANY ACTION BY YOU FOR BREACH OF CONTRACT MUST BE COMMENCED WITHIN 12 MONTHS AFTER THE DATE OF SALE.

Sales and Service

For information about our worldwide locations, approvals, certifications and local representative:

Web site: www.sartellvalves.com

E-Mail: info@sartellvalves.com

SARTELL Valves, Inc.



250 Riverside Ave. N., Sartell, MN 56377 • Phone: 320-259-2000 • Fax: 320-259-2227

Sartell Valves, Inc. reserves the right to incorporate our latest design and material changes without notice or obligation.

Design features, materials of construction and dimensional data, as described in this manual, are provided for your information only and should not be relied upon unless confirmed in writing by Sartell Valves, Inc. Certified drawings are available upon request.