

SARTELL  Valves &
Controls

3650-7200 PEC ECCENTRIC VALVES

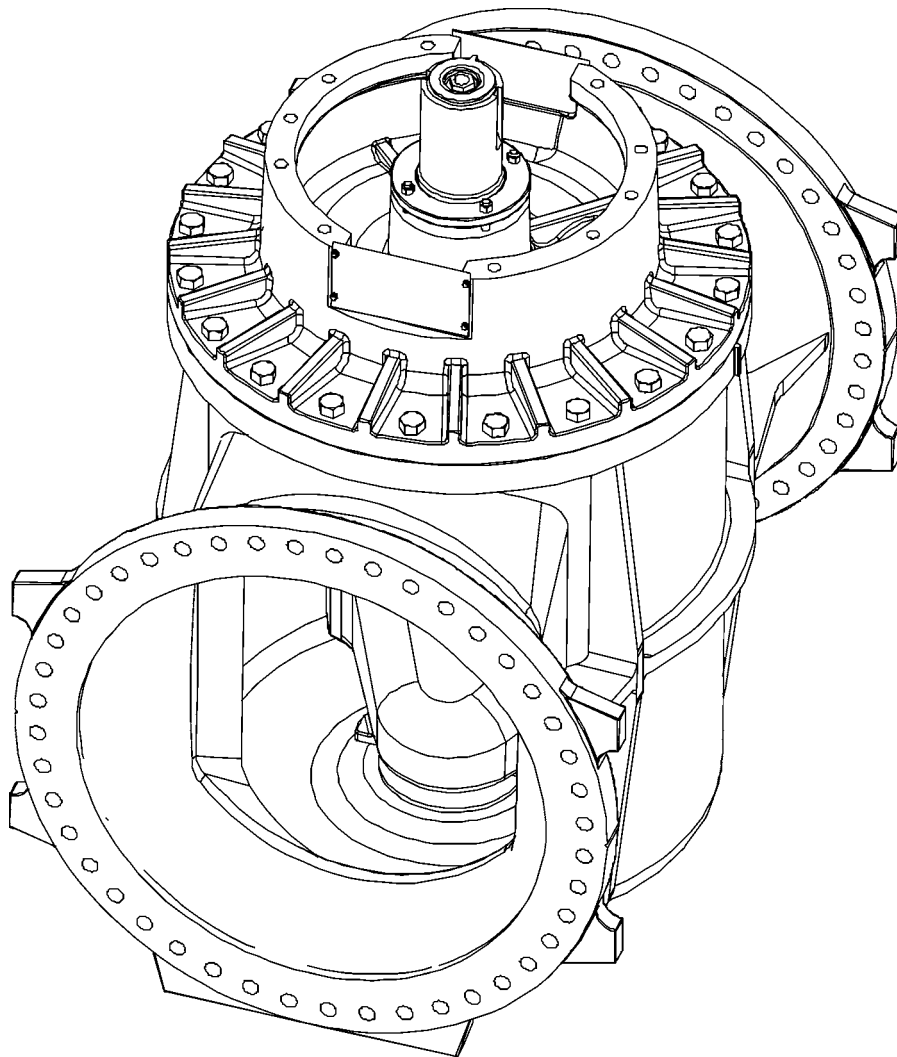

Instruction **DS10019**

July 2008

Instructions

These instructions provide information about PEC Eccentric Valves. They are for use by personnel who are responsible for installation, operation and maintenance of PEC Eccentric Valves.

Safety Messages

All safety messages in the instructions are flagged with an exclamation symbol and the word Caution, Warning or Danger. These messages indicate procedures that must be followed exactly to avoid equipment damage, personal injury or death. Safety label(s) on the product indicate hazards that can cause equipment damage, personal injury or death. If a safety label becomes difficult to see or read, or if a label has been removed, please contact SARTELL Valves & Controls for replacement label(s).



WARNING!

Personnel involved in the installation or maintenance of valves should be constantly alert to potential emission of pipeline material and take appropriate safety precautions. Always wear suitable protection when dealing with hazardous pipeline materials. Handle valves, which have been removed from service with suitable protection for any potential pipeline material in the valve.

Inspection

Your PEC Eccentric Valve has been packaged to provide protection during shipment; however, it can be damaged in transport. Carefully inspect the unit for damage upon arrival and file a claim with the carrier if damage is apparent.

Parts

Recommended spare parts are listed on the assembly drawing. These parts should be stocked to minimize downtime.

Order parts from your local SARTELL Valves & Controls sales representative, or directly from SARTELL Valves & Controls. When ordering parts, please include the 7-digit part number and 4-digit revision number (example: **9999999R000**) located on the data plate attached to the valve assembly. Also include the part name, the assembly drawing number, the balloon number and the quantity stated on the assembly drawing.

SARTELL Valves & Controls Service

SARTELL Valves & Controls service personnel are available to install, maintain and repair all SARTELL Valves & Controls products. SARTELL Valves & Controls also offers customized training programs and consultation services.

For more information, contact your local SARTELL Valves & Controls sales representative or visit our website at www.sartellvalves.com.

Table of Contents

Description - - - - -	4
Required Tools - - - - -	5
Exploded Assembly Drawing - - - - -	6
Installation - - - - -	7
Closed Position - - - - -	9
Lubrication - - - - -	9
Plug Orientation - - - - -	9
Packing Adjustment - - - - -	9
Packing Replacement	
<i>Replacing Packing with Actuator Removed</i> - - - - -	10
<i>Replacing Packing Without Removing Actuator</i> - - - - -	12
Disassembly - - - - -	12
Reassembly - - - - -	14
Removing Valve from Pipeline - - - - -	16
Field Test - - - - -	16
Emergency Operation - - - - -	16
Predicted Wear of Parts - - - - -	16
Troubleshooting - - - - -	17

Description

The 3650–7200 PEC Eccentric Valves have welded nickel seats that provide excellent resistance to corrosion and damage, and prolong the life of the resilient plug facing.

The valve rotates 90 degrees from full open to full closed. Clockwise rotation of the valve stem closes the valve.

If an actuator other than a SARTELL Valves & Controls is to be mounted, the actuator must be capable of maintaining the valve plug position with flow in the pipeline.

The following table shows sizes and port as a percentage of pipe area.

**Table A: Body and Flange Size and Valve Port Area
As a Percentage of Pipe Area**

Valve Size	Body Size	Flange Size	Valve Port Area vs. Pipe Area
3650	36"	36"	105%
4200	36"	42"	79%
4250	48"	42"	136%
4850	48"	48"	104%
5400	48"	54"	82%
5450	60"	54"	124%
6050	60"	60"	100%
6600	60"	66"	100%
7200	60"	72"	79%



WARNING!

This valve is a pressure vessel. Failure to release pipeline pressure may result in personal injury and/or flow system damage. Completely release pipeline pressure before removing the actuator from the valve or removing the valve from the pipeline.

Required Tools

To adjust the packing, you will need a socket and ratchet handle to remove the access cover screws.

- 1/2" socket for all sizes

To adjust the four packing nuts, you will need a combination wrench.

- 15/16" for sizes 3650 and 4200
- 1-1/8" for sizes 4250 thru 5400
- 1-5/16" for sizes 5450 thru 7200

To disassemble the valve, you will need the tools mentioned above, plus wrenches to remove the bonnet and lower journal.

You will need wedges and a dead blow hammer to help remove the bonnet from the body.

Lifting devices capable of handling the weights of the components are needed.

A fixture or counterbalance is needed for removing the plug from the body.

Approximate weights of the components are shown in Table B.

**Table B: Basic Valve and Component Weights
(does not include actuator weight)**

Valve Size	Valve Component Weights (pounds)				
	Total	Body	Plug	Bonnet	Journal Cover
3650	11,200	6,000	2,000	1,200	100
4200	11,500	6,200	2,000	1,200	100
4250	22,500	12,000	4,000	2,500	100
4850	23,000	12,500	4,000	2,500	175
5400	23,500	13,000	4,000	2,500	175
5450	36,000	17,000	7,000	4,000	175
6050	38,000	20,500	7,000	4,000	250
6600	39,000	23,000	7,000	4,000	250
7200	44,000	25,000	7,000	4,000	250

Exploded Assembly Drawing

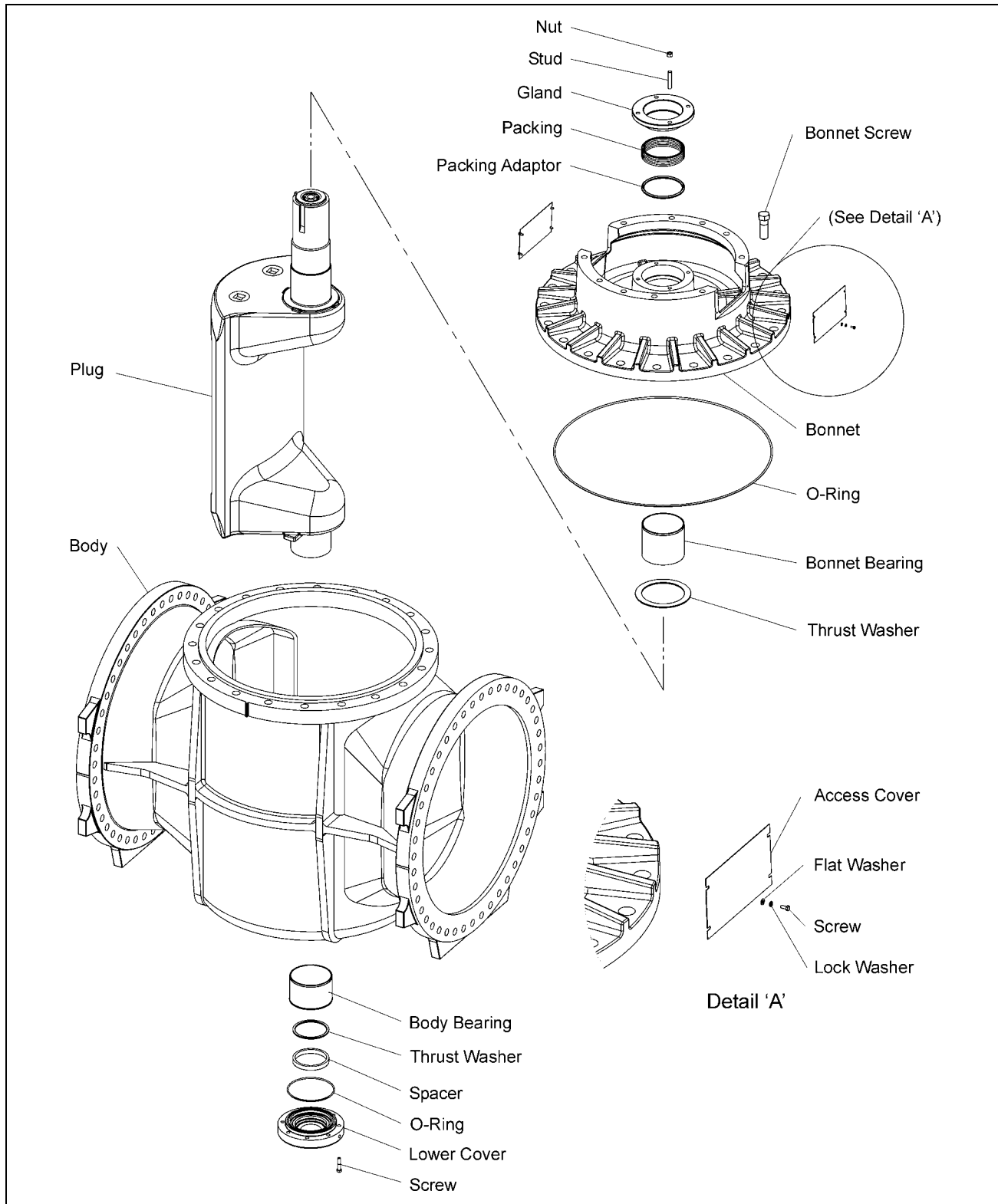

Figure 1— Exploded Assembly Drawing

Installation

The type of materials carried in the pipeline and the location of the valve determine the correct installation procedure.

Liquids and Gases

1. Before installation, remove foreign material such as weld spatter, oil, grease, and dirt from the valve and pipeline.
2. Install the valve as shown in Figure 2.

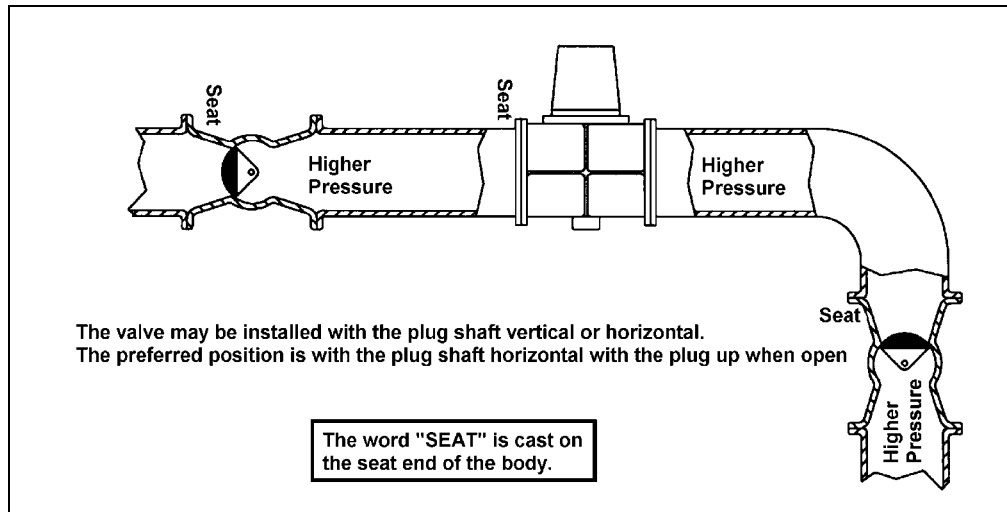

Figure 2 — Liquids and Gases

3. Ensure the valve and flanges are concentric to ensure proper flange sealing.
4. Tighten the flange bolts or studs in a crisscross pattern.

Installation (continued)

Suspended Solids

If the pipeline carries suspended solids such as paper stock of 2 percent or higher consistency, mining slurry, or raw sewage:

1. Before installation, remove foreign material such as weld spatter, oil, grease, and dirt from the valve and pipeline.
2. Install the valve as shown in Figure 3.
 - a. In HORIZONTAL pipelines, install the valve so that the plug is horizontal and rotates upward as the valve opens.
 - b. For VERTICAL pipelines, install the valve with the end marked "SEAT" at top of valve.

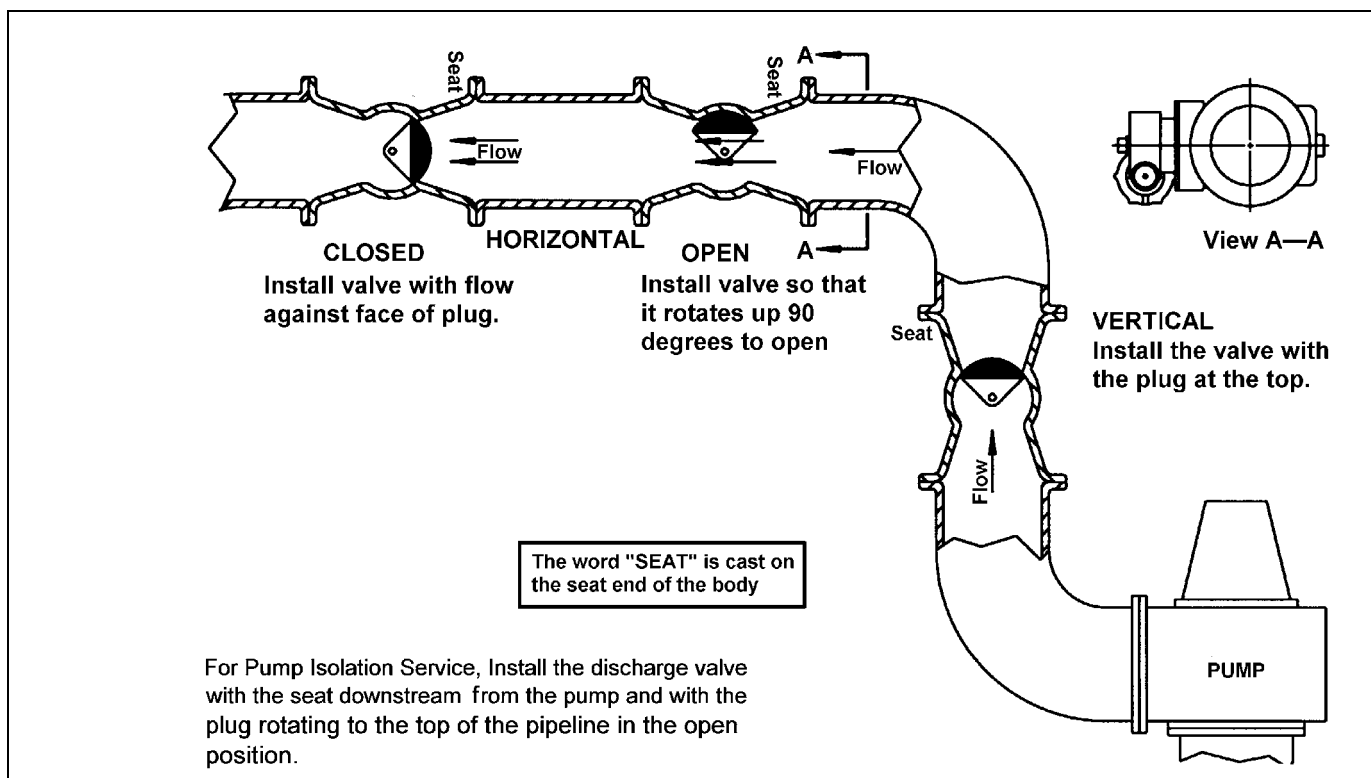

Figure 3 — Liquids with Suspended Solids

3. Tighten the flange bolts or studs in a crisscross pattern.
4. Ensure the valve and flanges are concentric to ensure proper flange sealing.

Closed Position

Because of the eccentric action of this valve, the closed position of the valve is dependent upon the pressure drop expected when the valve is closed.

To adjust the valve closed position, follow these steps:

1. Relieve pipeline pressure.



WARNING!

Moving parts from accidental operation of power actuator can cause personal injury or equipment damage. Disconnect and lock out power to actuator before servicing.

2. If the actuator is powered, disconnect and lock out the pneumatic, hydraulic, or electrical power to prevent accidental operation of the actuator.
3. Back off the actuator closed position stop as described in the Actuator Instructions.
4. Close the valve with the torque specified in the Actuator Instructions.
Note: This torque is the amount required to seat the plug for a given pressure drop across the valve. To avoid excessive plug and seat wear caused by over torquing, use the actual pressure drop across the valve when determining correct closing torque.
5. After the valve has been closed using the correct amount of torque, set the actuator closed position stop to limit actuator travel at this position.

Lubrication

This valve does not require routine lubrication.

If disassembled, lubricate the plug journals with a lubricant that is compatible with the flow media. For most applications, use one of these nickel based compound lubricants.

- Bostik Never-Seez (**recommended**)
- Keystone No-Weld #1 (alternate)

Plug Orientation

The orientation of the plug can be determined by the 1/2 inch wide cast lug on the plug stem. This lug is directly above the centerline of the plug face.

Packing Adjustment

To stop packing leakage, tighten the gland nuts uniformly until the leak stops.

Note: Do not continue tightening after leak stops. If the leak cannot be stopped by tightening the gland nuts, replace the packing.

Packing Replacement

Replacing Packing with Actuator Removed

To replace the packing without removing actuator, see “*Replacing Packing Without Removing Actuator*” section.

1. Discontinue pipeline flow and relieve pipeline pressure.
2. Scribe the actuator and valve bonnet for alignment when reassembling.



WARNING!

Moving parts from accidental operation of power actuator can cause personal injury or equipment damage. Disconnect and lock out power to actuator before servicing.

3. If the actuator is powered, disconnect and lock out the pneumatic, hydraulic, or electrical power to prevent accidental operation of the actuator.



WARNING!

When an eccentric valve is mounted in a vertical pipeline— or mounted in a horizontal pipeline with the plug stem horizontal—gravity can cause the plug to swing to a lower position in the valve body when the actuator is removed. Place the plug in the lowest position before removing the actuator.

4. Remove the actuator from the valve. See Actuator Instructions.
5. Remove the two access covers from the bonnet.
6. Remove the nuts that hold the packing gland in place, and slide the packing gland off the plug stem.
7. Remove the packing from the bonnet packing chamber.
8. Scrape the RTV silicone material from the top of the bonnet and access cover mounting surfaces.
9. Lubricate the new packing, then install it one ring at a time as shown in Figure 4.

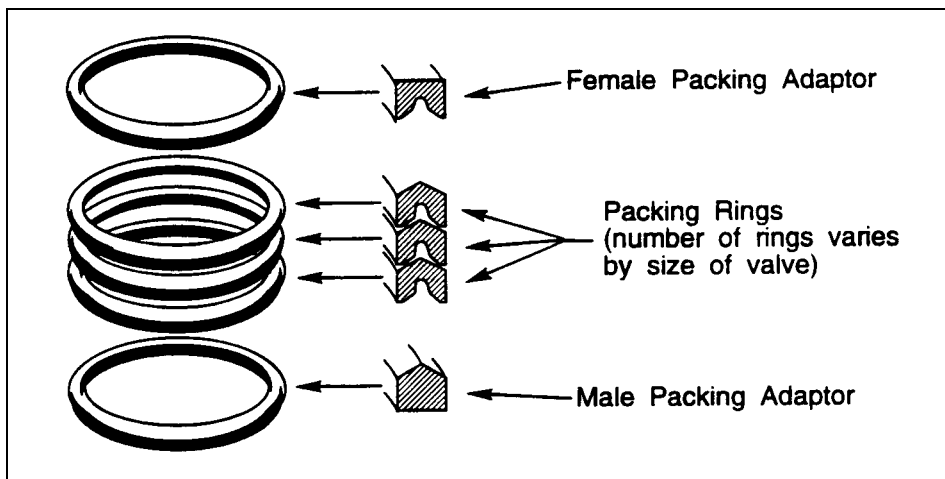

Figure 4 — Correct Packing Installation Sequence

Packing Replacement *(continued)*

- Slide the packing gland down the plug stem so the four studs in the bonnet go into the holes in the packing gland. Thread nuts onto the studs until they touch the gland, then tighten one more turn.

Note: This is a preliminary adjustment; it will be necessary to adjust the packing gland nuts after the valve is pressurized. See "Packing Adjustment" section.

- Apply RTV silicone sealant to the top of bonnet.
- Place the keys in the plug stem keyseats, then install the actuator mounting plate and actuator as described in the Actuator Instructions.
- After pipeline flow is restored, check the packing for leakage. If the packing leaks, tighten the packing gland nuts only enough to stop the leak. Over tightening the packing will result in premature packing failure and higher valve operating torque.
- Apply RTV silicone sealant to the access cover mounting surfaces, then fasten the two access covers on the sides of the bonnet.

Replacing Packing Without Removing Actuator



WARNING!

Excessive pipeline pressure can propel the loose packing, and can cause personal injury or equipment damage. If possible, relieve the pressure in the pipeline to 0 psi before removing the packing gland.

- Ensure that the pipeline pressure does not exceed 25 psi—if possible, relieve the pressure to 0 psi.
-



WARNING!

Caustic, toxic, or hot material in the pipeline can cause personal injury or death if leakage occurs. Confirm that the material is not harmful.

- Ensure that the material in the pipeline will not cause injury if leakage occurs.
- Remove the two access covers from the bonnet.
- Remove the packing gland nuts from the studs, and slide the packing gland up the stem of the plug.
- Remove the studs from the bonnet.
- Cut and completely remove all of the old packing from the packing chamber in the bonnet.
- Cut each new packing ring radially in one place with a razor-sharp knife.
- Place each new packing ring—one at a time with the joints staggered—around the plug and into position in the packing chamber.
- Replace the studs in the bonnet.

Packing Replacement *(continued)*

10. Push the rings down into position with the packing gland, and replace the packing gland nuts on the studs.
11. Turn the packing gland nuts onto the studs until they touch the packing gland, then one more turn.
12. Restore the pipeline pressure, and check for packing leakage. If leakage occurs, tighten each packing nut just enough to stop the leakage. Excessive tightening will cause reduced packing life and higher valve operating torque.
13. Scrape the old RTV sealant material from the access covers and mounting surfaces, then apply RTV silicone sealant to the access cover mounting surfaces and fasten the two access covers on the sides of the bonnet.

Disassembly

The main reason to disassemble a 3650 through 7200 valve would be to replace the plug because of damage to its rubber face. Because disassembly and reassembly are major operations, you might wish to repair the rubber face while the valve is still fully assembled. Consult the SARTELL Valves & Controls factory for the correct repair kit and procedure for your valve.

This valve was assembled at the factory using special jigs and fixtures that align the components and hold them in position during assembly. Without the use of these fixtures, field disassembly and reassembly are difficult and could result in damage to valve components, especially the rubber face of the plug.

To disassemble the valve, follow these steps.

Note: The lifting equipment used during the disassembly-reassembly must be properly sized to handle the weight of the valve and/or components. See the "Required Tools" section of these instructions for valve and component weights.

1. Relieve pipeline pressure and close the valve.



WARNING!

This valve is a pressure vessel. Pipeline pressure must be completely released before removing the actuator from the valve or the valve from the pipeline. Failure to release pipeline pressure may result in personal injury and/or flow system damage.

2. To disassemble the valve, it must be positioned so the plug is vertical and the bonnet is up.
3. Scribe corresponding lines on the actuator, actuator mounting plate, bonnet, plug stem and valve body to be used for component alignment during reassembly.
4. Remove the actuator from the valve as described in the Actuator Instructions.
5. Remove the two access covers from the bonnet.
6. Remove the screws that fasten the bonnet to the valve body.

Disassembly (continued)

7. Clamp onto the plug stem, and lift the bonnet and plug together from the valve body.



WARNING!

When the lower plug journal clears the lower bearing, the plug will swing suddenly toward the center of the valve. Take all precautions necessary so this sudden motion of the plug does not cause any personal injuries or equipment damage.

8. Lower the plug onto spacers so the bonnet can be removed. See Figure 5.
9. Remove the packing gland and packing from the bonnet.
10. Lift the bonnet off the end of the plug stem.
11. Remove the eight screws that fasten the lower journal cover in place and remove the cover from the valve body.
12. Remove the spacer and thrust washer.
13. Remove the journal bearings from the bonnet and the valve body.
14. Slide the thrust bearing off the top of the plug stem.

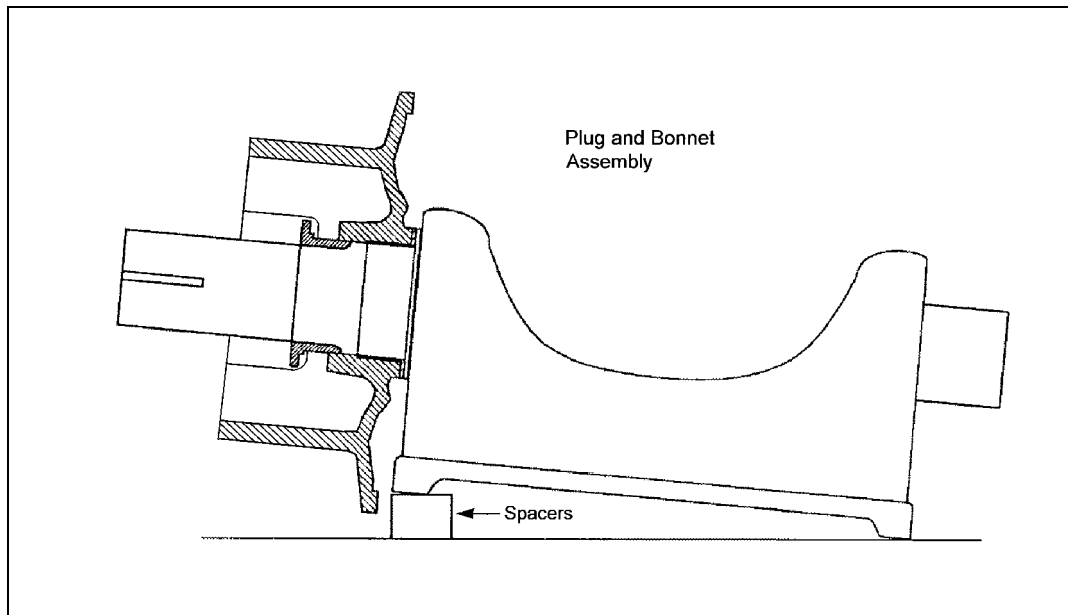

Figure 5 — Location of Spacers to Support Plug While Removing Bonnet

Reassembly

Installation of the plug during reassembly will be much easier if the body is blocked up so the bottom journal cover can be removed, and a bar used to guide the lower plug journal into the lower bearing.

To assemble the valve, carefully follow these steps

1. Push a new journal bearing into the bore in the bonnet, then lubricate the bearing as described in the LUBRICATION section of these instructions.
2. Push a new journal bearing into the bore in the valve body, then lubricate the bearing as described in the LUBRICATION section of these instructions.
3. Slide the thrust bearing down the plug stem.
4. Slide the bonnet down the plug stem until it contacts the thrust bearing. (See Figure 6)

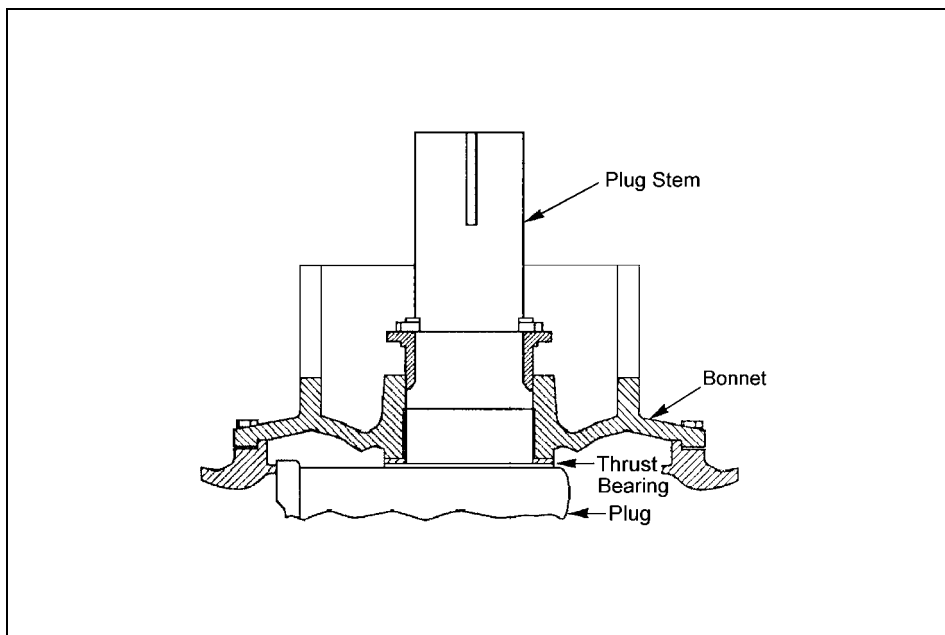

Figure 6 — Thrust Bearing Contacting Bonnet Inside of Valve

5. Lubricate the o-ring groove of the bonnet, then place the o-ring in the groove.
6. Clamp onto the plug stem and lift the bonnet and plug as an assembly.
7. Position the plug in the valve body as shown in Figure 7, then carefully lower the plug and bonnet assembly into the valve body while guiding the lower plug journal into the bottom bearing. Keep the rubber plug face away from the seat to avoid tearing the rubber facing.
8. Align the marks made during disassembly, then fasten the bonnet to the valve body.
9. Slide the packing adaptor down the plug stem and into the packing chamber in the bonnet.
10. Lubricate the packing, then push it, one ring at a time, into the packing chamber in the bonnet.

Reassembly (continued)

- Slide the packing gland down the plug stem so the four studs in the bonnet go into the holes in the packing gland. Thread nuts onto the studs until they touch the gland, then tighten one more turn.

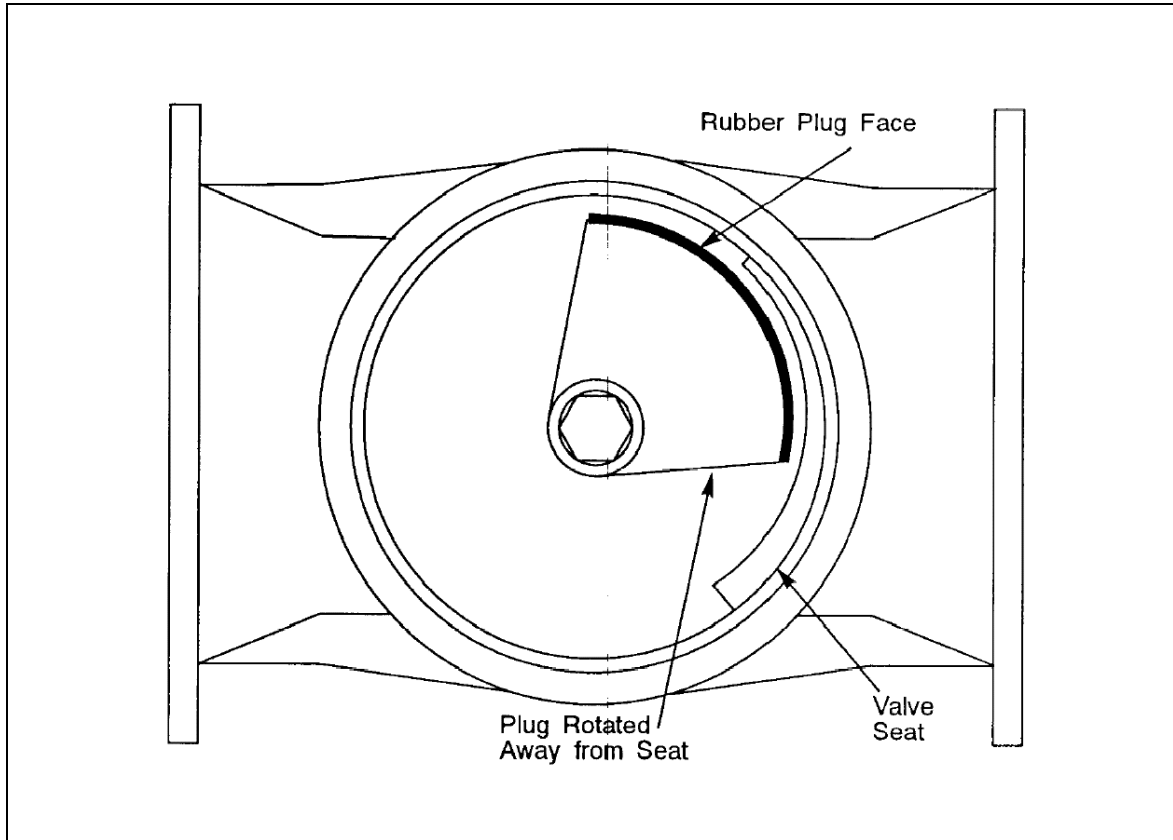

Figure 7 — Location of Plug and Valve Seat While Installing Plug in Valve Body

- Lubricate the bottom surface of the plug, then install the thrust washer to the plug bottom.
- Lubricate the spacer, then slide the spacer onto the bottom of the plug until it contacts the thrust washer.
- Lubricate the o-ring groove of the lower journal cover, insert the o-ring, then lift the cover into place making sure the spacer contacts the machined surface in the cover. Secure the cover to the valve body with eight screws.
- Place the keys in the plug stem keyseats. Apply RTV silicone sealant to the top of the bonnet, then install the actuator as described in the *Actuator Instructions*.
- If the valve was removed from the pipeline, reinstall it in the same orientation as originally installed.
- After pipeline flow is restored, check the packing for leakage. If it leaks, tighten the packing gland nuts only enough to stop the leak. Over tightening the packing will cause premature packing failure and higher valve operating torque.
- Apply RTV silicone sealant to the access cover mounting surfaces, then fasten the two access covers on the sides of the bonnet.

Removing Valve from Pipeline

To remove the entire valve assembly from the pipeline, follow these steps.



WARNING!

This valve is a pressure vessel. Failure to release pipeline pressure may result in personal injury and/or flow system damage. Completely release pipeline pressure before removing the actuator from the valve or removing the valve from the pipeline.

1. Relieve pipeline pressure and drain portion of system where valve is located.
 2. Close the valve.
-



WARNING!

Moving parts from accidental operation of power actuator can cause personal injury or equipment damage. Disconnect and lock out power to actuator before servicing.

3. If the actuator is powered, disconnect and lock out the pneumatic, hydraulic, or electrical power to prevent accidental operation of the actuator.
4. Support the valve assembly, then remove the flange bolts.
5. Remove the valve from the pipeline.

Field Test

Stroke the valve between the fully open and fully closed positions to verify that the valve and actuator are functioning properly.

Emergency Operation

Operate the valve as under normal conditions, taking care to bring the plug to the position required by the particular emergency condition.

Predicted Wear of Parts

Length of service for parts subject to wear is dependent on service conditions.

Troubleshooting

Symptom	Possible Cause	Corrective Action
Packing Leaks.	Packing is loose.	Adjust Packing. (See <i>Packing Adjustment</i> section)
	Packing is worn.	Replace Packing. (See <i>Packing Replacement</i> section)
Valve does not close.	Object is wedged between plug and seat.	Completely open the valve to flush object from the valve. If flushing does not work, remove valve from the pipeline and remove object. (See <i>Removing Valve from Pipeline</i> section)
	Actuator closed position is out of adjustment.	Adjust the closed position stop. See Actuator Instructions.
Valve leaks when closed.	Plug is worn or damaged.	Replace plug. See <i>Disassembly</i> and <i>Reassembly</i> sections.
	Rubber on plug is torn.	

Guarantee

Products, auxiliaries and parts thereof of Sartell Valves, Inc. manufacture are warranted to the original purchaser for a period of twenty-four (24) months from date of shipment from factory, against defective workmanship and material, but only if properly installed, operated and serviced in accordance with Sartell Valves, Inc. recommendations. Repair or replacement, at our option, for items of Sartell Valves, Inc. manufacture will be made free of charge, (FOB) our facility with removal, transportation and installation at your cost, if proved to be defective within such time, and this is your sole remedy with respect to such products. Equipment or parts manufactured by others but furnished by Sartell Valves, Inc. will be repaired or replaced, but only to the extent provided in and honored by the original manufacturers warranty to Sartell Valves, Inc., in each case subject to the limitations contained therein. No claim for transportation, labor or special or consequential damages or any other loss, cost or damage shall be allowed. You shall be solely responsible for determining suitability for use and in no event shall Sartell Valves, Inc. be liable in this respect. Sartell Valves, Inc. does not guarantee resistance to corrosion, erosion, abrasion or other sources of failure, nor does Sartell Valves, Inc. guarantee a minimum length of service. Your failure to give written notice to us of any alleged defect under this warranty within twenty (20) days of its discovery, or attempts by someone other than Sartell Valves, Inc. or its authorized representatives to remedy the alleged defects therein, or failure to return product or parts for repair or replacement as herein provided, or failure to install and operate said products and parts according to instructions furnished by Sartell Valves, Inc., or misuse, modification, abuse or alteration of such product, accident, fire, flood or other Act of God, or failure to pay entire contract price when due shall be a waiver by you of all rights under this warranty.

The foregoing guarantee shall be null and void if, after shipment from our factory, the item is modified in any way or a component of another manufacturer, such as but not limited to, an actuator is attached to the item by anyone other than Sartell Valves, Inc. Factory Service personnel. All orders accepted shall be deemed accepted subject to this limited warranty, which shall be exclusive of any other or previous Warranty, and this shall be the only effective guarantee or warranty binding on Sartell Valves, Inc., despite anything to the contrary contained in the purchase order or represented by any agent or employee of Sartell Valves, Inc., in writing or otherwise, notwithstanding, including but not limited to implied warranties.

THE FOREGOING REPAIR AND REPLACEMENT OBLIGATIONS ARE IN LIEU OF ALL OTHER WARRANTIES, OBLIGATIONS AND LIABILITIES, INCLUDING ALL WARRANTIES OF FITNESS FOR A PARTICULAR PURPOSE OR OF MERCHANTABILITY OR OTHERWISE, EXPRESSED OR IMPLIED IN FACT OR BY LAW, AND STATE SARTELL VALVES, INC.'S ENTIRE AND EXCLUSIVE LIABILITY AND YOUR EXCLUSIVE REMEDY FOR ANY CLAIM IN CONNECTION WITH THE SALE AND FURNISHING OF SERVICES, GOODS OR PARTS, THEIR DESIGN, SUITABILITY FOR USE, INSTALLATION OR OPERATIONS.

Limitation of liability

LIMITATION OF LIABILITY: IN NO EVENT SHALL SARTELL VALVES, INC. BE LIABLE FOR ANY DIRECT, INDIRECT, SPECIAL OR CONSEQUENTIAL DAMAGES WHATSOEVER, AND SARTELL VALVES, INC.'S LIABILITY, UNDER NO CIRCUMSTANCES, WILL EXCEED THE CONTRACT PRICE FOR THE GOODS AND/OR SERVICES FOR WHICH LIABILITY IS CLAIMED. ANY ACTION BY YOU FOR BREACH OF CONTRACT MUST BE COMMENCED WITHIN 12 MONTHS AFTER THE DATE OF SALE.

Sales and Service

For information about our worldwide locations, approvals, certifications and local representative:

Web site: www.sartellvalves.com

E-Mail: info@sartellvalves.com

SARTELL Valves, Inc.



250 Riverside Ave. N., Sartell, MN 56377 • Phone: 320-259-2000 • Fax: 320-259-2227

Sartell Valves, Inc. reserves the right to incorporate our latest design and material changes without notice or obligation.

Design features, materials of construction and dimensional data, as described in this manual, are provided for your information only and should not be relied upon unless confirmed in writing by Sartell Valves, Inc. Certified drawings are available upon request.