



AFR2 AIR FILTER REGULATOR

General

The AFR2 Instrument Air Filter Regulator is designed to provide clean, accurate air pressure to DeZURIK actuators and positioners. This filter regulator has been proven to provide accurate operating characteristics under variable conditions. Durable materials and a standard epoxy paint finish provide long lasting corrosion resistance in harsh industrial environments. The AFR2 is a quality unit that is ideal as an economical alternative for control of process applications.

- **Stable Output and Repeatability**
Provides constant control under variable flow rates and supply pressures.
- **Corrosion-Resistant Construction**
Aluminum die-castings are finished with irridite and baked epoxy paint.
- **Depth Filter**
Unit comes equipped with high capacity 5 micron filter housed in dripwell for complete air filtration.
- **Self-Relieving**
- **Low Droop at High Flow Levels**
Aspirator design helps maintain set pressure at higher flow levels.
- **Tight Shutoff**
A soft, rubberized valve provides a positive shutoff and compensates for dirt and other foreign matter.



Materials of Construction

Body	Diecast Aluminum Alloy, Iridite and Baked Epoxy Finish
Filter	5 Micron Phenolic Impregnated Cellulose as standard, 3 micron on application
Diaphragm	Nitrile Elastomer and Nylon Fabric
Valve Seat Plug	Nitrile Elastomer
Additional Materials	Brass, Zinc Plated Steel, Acetal

Principle of Operation

Turning the adjusting screw changes the force exerted by the range spring on the diaphragm assembly. In equilibrium of set pressure, the force exerted by the range spring is balanced by the force from the output pressure acting underneath the diaphragm assembly.

An unbalanced state between the output pressure and the set pressure causes a corresponding reaction in the diaphragm and supply valve assemblies. If the output pressure rises above the set pressure, an upward force is exerted on the diaphragm assembly causing the relief seat to lift and open. Excess pressure is vented to atmosphere until equilibrium is reached. If the output pressure drops below the set pressure, the unbalanced force of the range spring causes a downward force on the diaphragm assembly. The supply valve opens until the pressure builds up once more to the equilibrium condition.

Under forward flow conditions, the range spring force is balanced by the diaphragm pressure force, with the supply valve open just enough to maintain the required equilibrium pressure. When high flow occurs, a specially designed aspirator helps maintain downstream pressure and compensates for droop.

Specifications

Port Size	(In, Out and Gauge) 1/4" N.P.T.
Output Ranges	0-120 psig (0-800 kPa)
Maximum Supply Pressure	250 psig (1700 kPa)
Mounting	Pipe or Through Body
Flow Capacity	33 SCFM (56.1 m ³ /hr) at 90 psig (620 kPa) supply with 20 psig (140 kPa) output
Exhaust Capacity	0.1 SCFM (0.17 m ³ /hr) with downstream pressure 5 psig (35 kPa) above set point
Sensitivity	1" (2.5 cm) of water
Air Consumption	less than 5 SCFH (0.17m ³ /hr)
Effect of Supply Pressure Variation	less than .2 psig (1.4 kPa) for 25 psi (170 kPa) change
Weight	1.6 lb. (725 g)

Ordering

To order AFR2 add the code AFR2 after the valve/actuator order code.

Ordering Example:

PEC, 6, F1, CI, NBR, CR*GS-6-PC6, 4V2110-AFR2

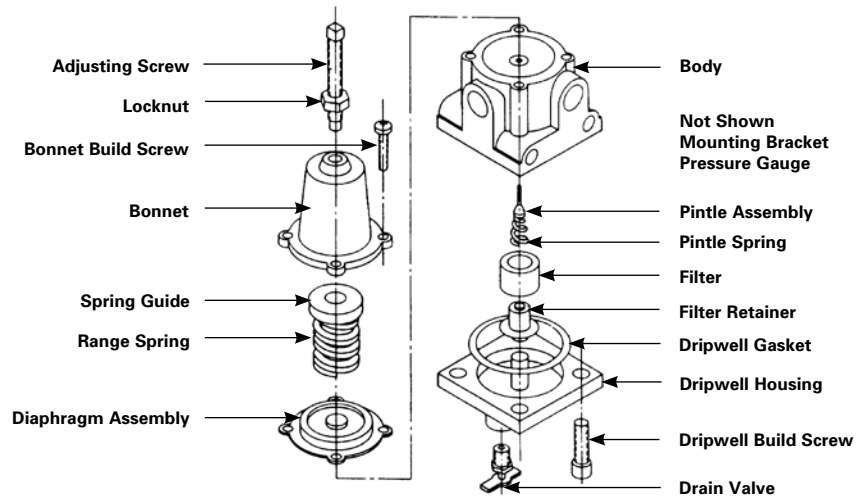

Sales and Service

For information about our worldwide locations, approvals, certifications and local representative:

Web Site: www.dezurik.com E-Mail: info@dezurik.com



250 Riverside Ave. N. Sartell, Minnesota 56377 • Phone: 320-259-2000 • Fax: 320-259-2227

DeZURIK reserves the right to incorporate our latest design and material changes without notice or obligation. Design features, materials of construction and dimensional data, as described in this bulletin, are provided for your information only and should not be relied upon unless confirmed in writing by DeZURIK. Certified drawings are available upon request.