

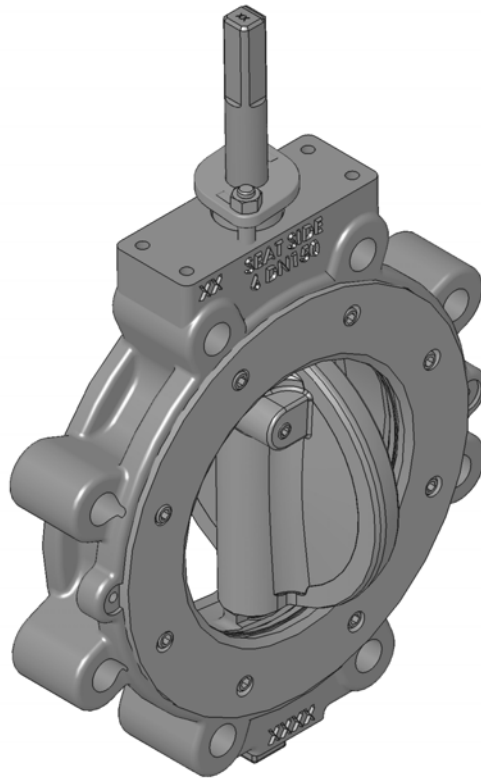

APCO | WILLAMETTE

DeZURIK BHP HIGH PERFORMANCE BUTTERFLY VALVE

(S10, S2A, S3A, S5A, AAA, HCA, MLA, T2A & T5A SHAFTS)



Instruction D10487
June 2011

DeZURIK

BHP High Performance Butterfly Valves

(S10, S2A, S3A, S5A, AAA, HCA, MLA, T2A & T5A Shafts)

Instructions

These instructions provide information about the DeZURIK High Performance Butterfly Valve. They are for use by personnel who are responsible for installation, operation and maintenance of High Performance Butterfly Valve.

Safety Messages

All safety messages in the instructions are flagged with an exclamation symbol and the word Caution, Warning or Danger. These messages indicate procedures that must be followed exactly to avoid equipment damage, personal injury or death.

Safety label(s) on the product indicate hazards that can cause equipment damage, personal injury or death. If a safety label becomes difficult to see or read, or if a label has been removed, please contact DeZURIK for replacement label(s).



WARNING!

Personnel involved in the installation or maintenance of valves should be constantly alert to potential emission of pipeline material and take appropriate safety precautions. Always wear suitable protection when dealing with hazardous pipeline materials. Handle valves, which have been removed from service with suitable protection for any potential pipeline material in the valve.

Inspection

Your High Performance Butterfly Valve has been packaged to provide protection during shipment; however, it can be damaged in transport. Carefully inspect the unit for damage upon arrival and file a claim with the carrier if damage is apparent.

Parts

Recommended spare parts are listed on the assembly drawing. These parts should be stocked to minimize downtime.

Order parts from your DeZURIK sales representative, or directly from DeZURIK. When ordering parts, please include the 7-digit part number and 4-digit revision number (example: **9999999R000**) located on the data plate attached to the valve assembly. Also include the part name, the assembly drawing number, the balloon number and the quantity stated on the assembly drawing.

DeZURIK Service

DeZURIK service personnel are available to install, maintain and repair all DeZURIK products. DeZURIK also offers customized training programs and consultation services.

For more information, contact your local DeZURIK sales representative or visit our website at www.dezurik.com.

Table of Contents

Description - - - - -	4
Installing Valve - - - - -	4
<i>Requirements</i> - - - - -	4
<i>Installing Valve</i> - - - - -	4
Operation - - - - -	5
Required Tools - - - - -	5
Lubrication - - - - -	5
Adjusting Packing - - - - -	5
Drawings - - - - -	6
Replacing Packing - - - - -	7
<i>PTFE V-Flex Dual-Seal Live-Loaded Packing Option (TCDL)</i> - - - - -	8
<i>PTFE V-Flex Packing Option (TC)</i> - - - - -	9
<i>PTFE Dual-Seal with Mechanical Spring Packing Option (TMD)</i> - - - - -	10
<i>PTFE V-Flex Live-Loaded Packing Option (TCL)</i> - - - - -	11
<i>Carbon Graphite Packing Option (G1)</i> - - - - -	12
<i>Graphoil Packing Option (G2)</i> - - - - -	12
<i>Graphoil Live-Loaded Packing Option (G2L)</i> - - - - -	13
<i>Graphoil Dual-Seal Packing Option (G2D)</i> - - - - -	14
<i>Graphoil Dual-Seal Live-Loaded Packing Option (G2LD)</i> - - - - -	15
Torque Specification - - - - -	17
Seat Replacement	
<i>Removing Valve From Pipeline</i> - - - - -	20
<i>Replacing the Seat</i> - - - - -	20
<i>Resilient Seat Options (TT, TI, RT and RI)</i> - - - - -	21
<i>Metal Seat Option (S2)</i> - - - - -	22
<i>Fyre-Block™ Seat Options (RTS2, TTS2, TIS2, and RIS2)</i> - - - - -	23
Valve Disassembly - - - - -	24
Bearing Replacement - - - - -	25
<i>Bearing Removal</i> - - - - -	25
<i>Bearing Replacement</i> - - - - -	25
Valve Reassembly - - - - -	26
Troubleshooting - - - - -	29

DeZURIK

BHP High Performance Butterfly Valves

(S10, S2A, S3A, S5A, AAA, HCA, MLA, T2A & T5A Shafts)

Description

The High Performance Butterfly Valve is designed for on-off and throttling applications in the chemical, power, paper, air conditioning, petroleum and refining industries.

A choice of body styles, ratings, seat and packing options, materials, actuators and accessories is available in valve sizes from 2–48" (50–1200mm). Pressure and temperature ratings are shown on the valve data plate.

Installing Valve

Recommendations

Refer to the valve installation drawing for dimensional information.

- Installing the valve in the wrong location may cause excessive dynamic torque and damage the valve. When pipeline fluid velocities exceed 20 fps (6.0 m/s) for 12" (300mm) and smaller valves or 12 fps (3.6 m/s) for 14" (350mm) and larger valves, it is recommended to install the valve at least 8 diameters from the nearest upstream elbow or pump. For best performance results, install valve shaft parallel with elbow or pump cross section (see image below). For more specific installation recommendations, contact your local representative or DeZURIK for assistance.

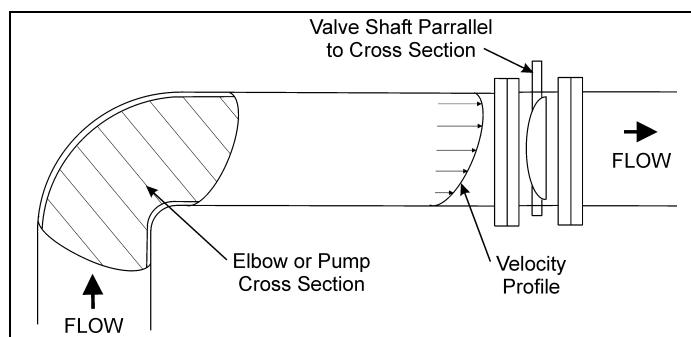

- Valves with undrilled seat retainers are not suitable for dead-end service without a downstream flange.
- If possible, install the valve with the shaft horizontal to provide a self-cleaning action on the seat.

Install the valve so that the seat will be on the higher pressure side when the valve is closed. The seat side of the valve is marked "SEAT". Pipeline flow may be in either direction through the valve.

- **Valves with metal seat option must be installed with higher pressure on the seat side** — this is the recommended direction on all other seat options.

Use self-centering flat ring flange gaskets.

- For 2–24" (50–600mm) Class 150 and Class 300 valves, use mating flanges that comply with the same class of ASME/ANSI B16.5.
- For larger sizes, use flanges that comply with the Class 150, Series A requirements of ASME B16.47.

Installing Valve

**CAUTION!**

Lifting the valve incorrectly can damage it. Do not fasten lifting devices to the actuator or disc, or through the seat opening in the body. Lift the valve with slings fastened around the valve body or attach them to bolts or rods run through holes for the pipeline flanges.

1. If the valve does not have an actuator, mount the actuator on the valve. Refer as necessary to the actuator instructions and drawings.
2. Remove all foreign material such as weld spatter, oil, grease and dirt from the valve, flanges and pipeline.
3. Open the valve and clean the seat and the sealing edge of the disc.
4. Place the valve in the pipeline with the valve closed—handle the valve carefully so that the flange gasket sealing surfaces do not get damaged.

Note: Valves with metal seat option must be installed with higher pressure on the seat side — this is the recommended direction for all other seat options.

5. Ensure that the valve, the pipeline and the mating connections are aligned and centered before tightening the pipeline bolts.
6. Tighten the bolts evenly, in a crisscross pattern.

Operation

Clockwise rotation of the valve shaft closes the disc into the seat. A line on the top of the valve shaft indicates the position of the disc when the disc is not visible.

The valve is fully closed when the flat side of the disc is parallel with the flange sealing surface on the body. The valve is fully open when the disc is 90° counterclockwise from the closed position.

Note: The closed disc must not touch the stop lug in the body.

The actuator is connected to the valve shaft and positions the disc at the open, closed or intermediate positions. The position stops in the actuator are set to match the open and closed positions of the valve.

Note: Refer to the actuator instructions for stop adjustment information.

Required Tools

This valve is assembled using only SAE fasteners. To service this unit, you should have a full set of combination wrenches, Allen wrenches, a flat tipped screwdriver, a pin punch and a dead blow hammer.

Lubrication

The valve is lubricated at the factory and does not require lubrication except when it is being reassembled. Refer to the actuator instructions for actuator lubrication requirements.

Adjusting Packing

The shaft seal consists of packing that is contained and compressed by the packing gland (A12).

1. If the packing leaks, tighten the two adjustment nuts (A15) on top of the packing gland (A12).

Note: Tighten the nuts evenly and gently—just enough to stop the leak. Over tightening will cause excessive torque and decrease packing life.

2. If the leak cannot be stopped by tightening the packing, replace the packing. See "Replacing Packing" section.

DeZURIK

BHP High Performance Butterfly Valves

(S10, S2A, S3A, S5A, AAA, HCA, MLA, T2A & T5A Shafts)

Drawings

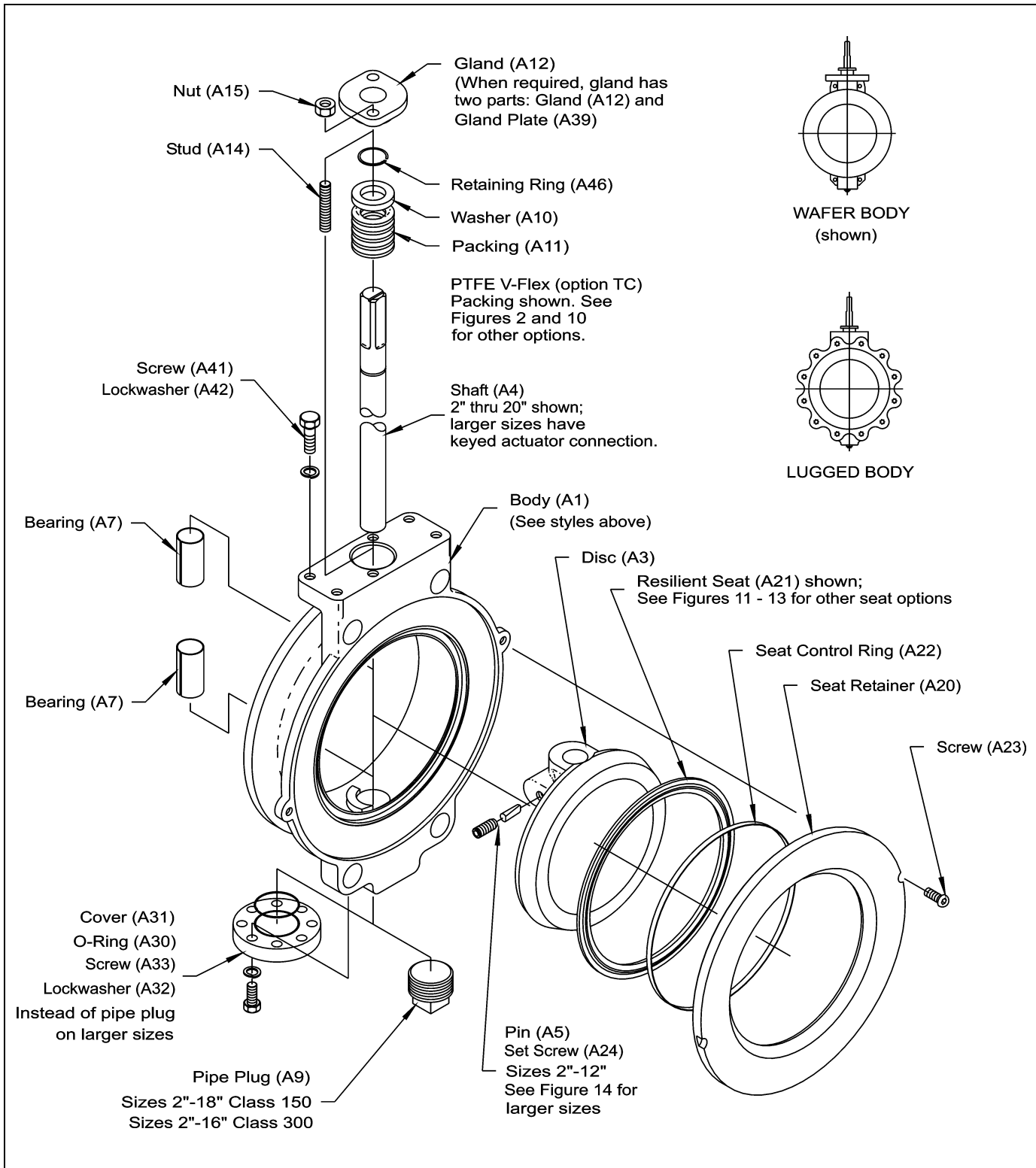

Figure 1 – Component Identification

Replacing Packing

Several packing options are available. See Figure 1 for parts identification.

**WARNING!**

Pipeline pressure can cause personal injury or equipment damage. Relieve the pressure in the pipeline before removing the packing gland.

1. Discontinue flow and relieve pipeline pressure.
-

**WARNING!**

Accidental operation of powered actuator can cause personal injury or equipment damage. Disconnect and lock out power to actuator before servicing.

2. If the actuator is powered, disconnect and lock out the power to the actuator.
3. Remove the actuator as described in the actuator instructions and remove the actuator bracket from the valve.
4. Remove the two gland nuts (A15) and remove the gland (A12).

Note: Live-loaded packing options include a flat washer (A37) and several spring washers (A36) under each gland nut. When required, the gland consists of two pieces: gland (A12) and gland plate (A39).

5. Remove the retaining ring (A46) from the shaft (A4).
6. Remove the packing washer (A10) and all of the packing (A11).
7. If the valve has the dual packing option, remove the secondary packing chamber (A17), the gasket (A16) and the secondary packing (A26).
8. Remove any packing fragments and ensure that all packing chamber sealing surfaces are clean.
9. Follow the procedure for the applicable packing option:
 - PTFE V-Flex Dual-Seal Live-Loaded Packing Option (TCDL) —page 8
 - PTFE V-Flex Packing Option (TC) —page 9
 - PTFE Dual-Seal with Mechanical Spring Packing Option (TMD) —page 10
 - PTFE V-Flex Live-Loaded Packing Option (TCL) —page 11
 - Carbon Graphite Packing Option (G1) —page 12
 - Graphoil Packing Option (G2) —page 12
 - Graphoil Live-Loaded Packing Option (G2L) —page 13
 - Graphoil Dual-Seal Packing Option (G2D) —page 14
 - Graphoil Dual-Seal Live-Loaded Packing Option (G2DL) —page 15

Replacing Packing (Continued)**PTFE V-Flex Dual-Seal Live-Loaded Packing Option (TCDL)**

The new primary packing (A11) and the new secondary packing (A26) each consist of one bottom end ring, three or more chevron rings and one top end ring. A quantity of new spring washers (A36) is required as shown in Table A (page 17) for Class 150 valves and in Table B (page 18) for Class 300 valves.

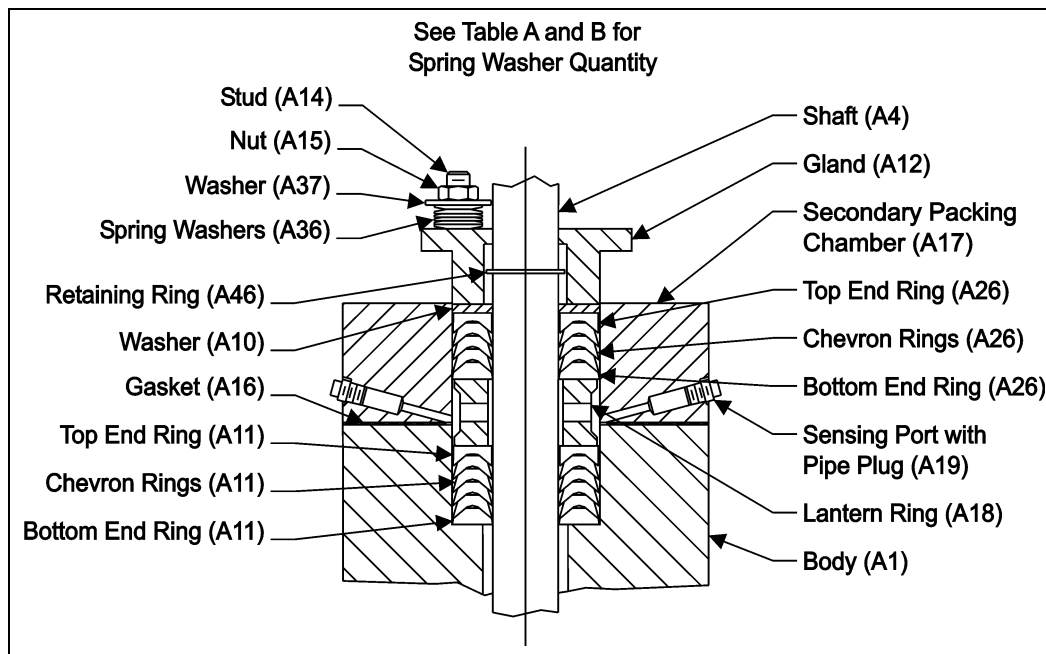

Figure 2 – Packing Option (TCDL)

- Place the primary (lower) set of packing (A11) in the body, one ring at a time, in the configuration shown in Figure 2. Do not lubricate. Start each chevron ring into the packing chamber at a slight angle and push each ring carefully into position so that the sealing lips do not bend over.
- Place the new gasket (A16), the secondary packing chamber (A17) and the lantern ring (A18) in the configuration shown in Figure 2.
- Place the secondary (upper) set of packing (A26) in the secondary packing chamber (A17), one ring at a time—do not lubricate. Start each chevron ring into the packing chamber at a slight angle and push each ring carefully into position so that the sealing lips do not bend over.
- Place the packing washer (A10) in the secondary packing chamber.
- Lubricate the threads of the two studs (A14) and the threads and contact faces of the two gland nuts (A15).
- Install the retaining ring (A46) into the groove in the shaft (A4).
- Replace the gland (A12), the new spring washers (A36), the two flat washers (A37) and the two gland nuts (A15). Arrange the spring washers with the top and bottom washers in series and the remaining washers in parallel as shown above. Do not tighten the nuts.
- Mount the actuator bracket and the secondary packing chamber to the body with the same screws and tighten the screws as shown in Table C (page 19).

Replacing Packing (Continued)

- i. Tighten the gland nuts (A15) finger tight and torque the nuts evenly to the value in Table A for Class 150 valves and in Table B for Class 300 valves. Continue with step 10 on page 16.

PTFE V-Flex Packing Option (TC)

The new packing (A11) consists of one bottom end ring, three or more chevron rings and one top end ring.

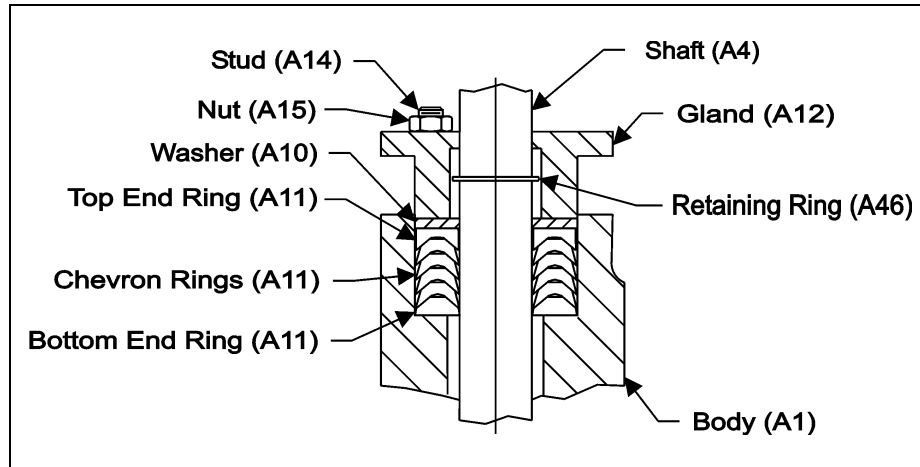

Figure 3 – Packing Option (TC)

- a. Place the packing in the body, one ring at a time, in the configuration shown in Figure 3. Do not lubricate.

Note: Start each chevron ring into the packing chamber at a slight angle and push each ring carefully into position so that the sealing lips do not bend over.
- b. Place the packing washer (A10) into the packing chamber.
- c. Install the retaining ring (A46) into the groove in the shaft.
- d. Replace the gland (A12) and the two gland nuts (A15). Tighten the nuts finger tight, plus ½ turn.
- e. Continue with step 10 on page 16.

Replacing Packing (Continued)**PTFE Dual-Seal with Mechanical Spring Packing Option (TMD)**

The new primary packing (A11) consists of one spring-loaded bottom end ring, three or more chevron rings and one top end ring, all between two anti-extrusion washers (A34); the new secondary packing (A26) consists of one bottom end ring, three or more chevron rings and one top end ring, all between two anti-extrusion washers (A34).

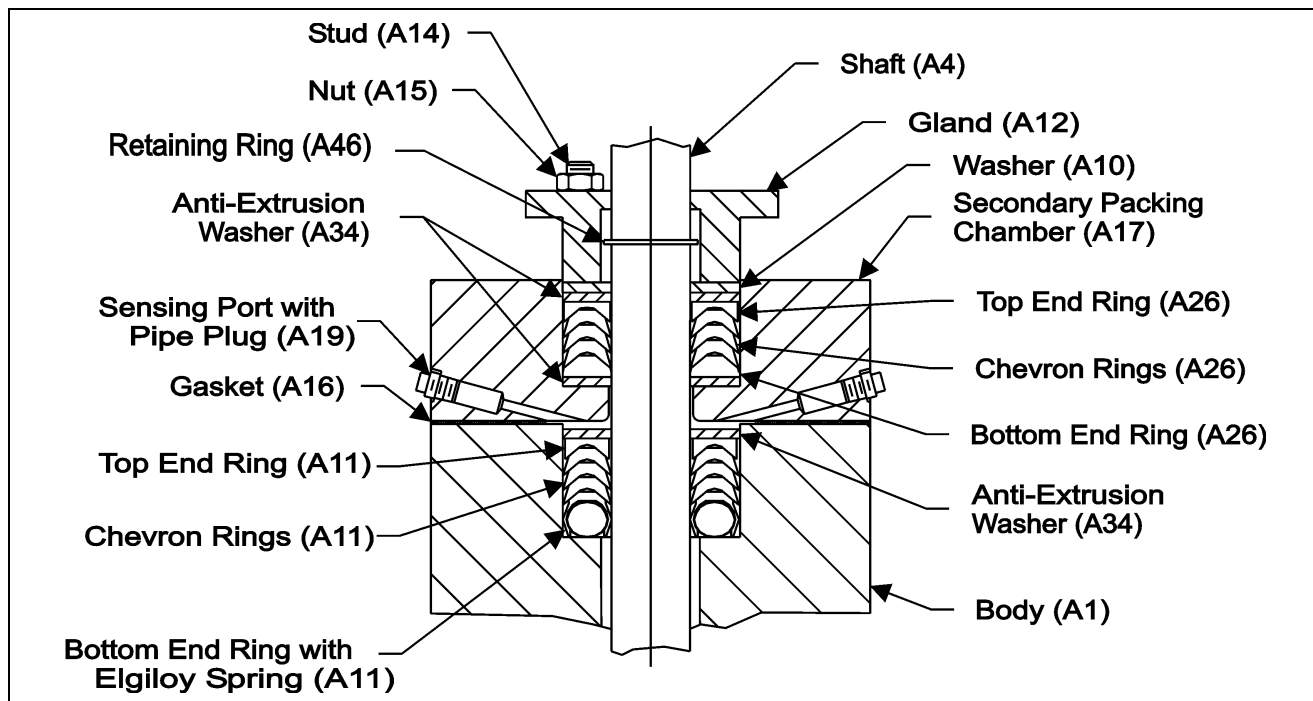

Figure 4 – Packing Option (TMD)

- a. Place the primary (lower) set of new packing (A11) and anti-extrusion washers (A34) in the body, one ring at a time, as shown in Figure 4—do not lubricate.
- b. Place the new gasket (A16), the secondary packing chamber (A17) and the new secondary packing (A26), one ring at a time, in the configuration shown in Figure 4—do not lubricate.

Note: Start each chevron ring into the packing chamber at a slight angle and push each ring carefully into position so that the sealing lips do not bend over.
- c. Place the packing washer (A10) into the secondary packing chamber.
- d. Install the retaining ring (A46) into the groove in the shaft.
- e. Place the gland (A12) and the two gland nuts (A15) in position as shown—do not tighten the nuts.
- f. Mount the actuator bracket and the secondary packing chamber to the body with the same screws and tighten the screws as shown in Table C on page 19.
- g. Tighten the gland nuts (A15) finger tight, plus ½ turn.
- h. Continue with step 10 on page 16.

Replacing Packing (Continued)**PTFE V-Flex Live-Loaded Packing Option (TCL)**

The new packing (A11) consists of one bottom end ring, three or more chevron rings and one top end ring. A quantity of new spring washers (A36) is required as shown in Table A for Class 150 valves and in Table B for Class 300 valves.

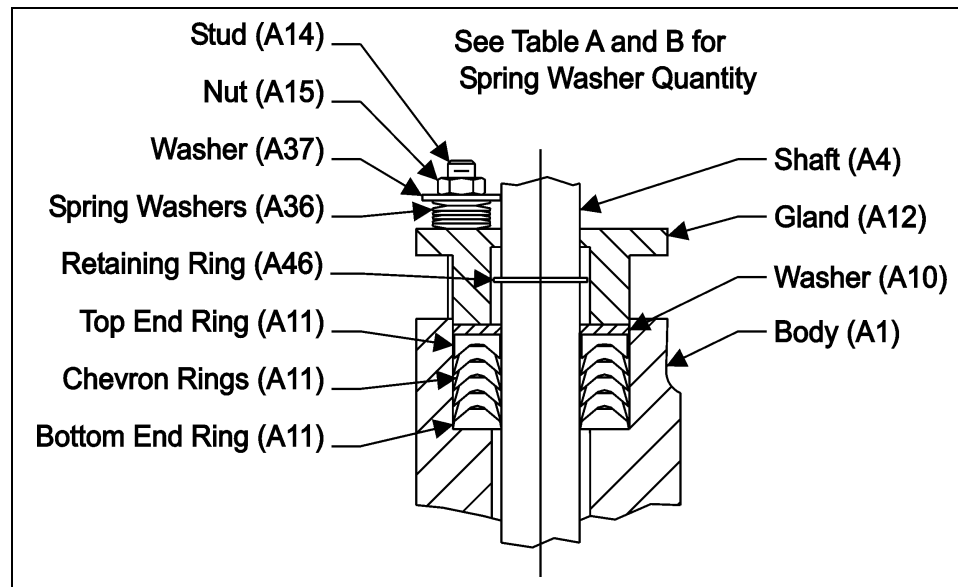

Figure 5 — Packing Option (TCL)

- a. Place the packing in the body, one ring at a time, in the configuration shown in Figure 5—do not lubricate.

Note: Start each chevron ring into the packing chamber at a slight angle and push each ring carefully into position so that the sealing lips do not bend over.

- b. Place the packing washer (A10) into the packing chamber.
- c. Lubricate the following surfaces:
 - The threads of the two studs (A14)
 - The threads and contact faces of the two gland nuts (A15)
- d. Install the retaining ring (A46) into the groove in the shaft.
- e. Replace the gland (A12), the new spring washers (A36), the two flat washers (A37) and the two gland nuts (A15).

Note: Arrange the spring washers in the configuration shown in Figure 8 on page 13, with the top and bottom washers in series and the remaining washers in parallel.

- f. Tighten the nuts finger tight and torque the nuts evenly to the value in Table A (page 17) for Class 150 valves and in Table B (page 18) for Class 300 valves.
- g. Continue with step 10 on page 16.

Replacing Packing (Continued)

Carbon Graphite Packing Option (G1)

The new packing (A11) consists of one Graphoil ring and two carbon rings.

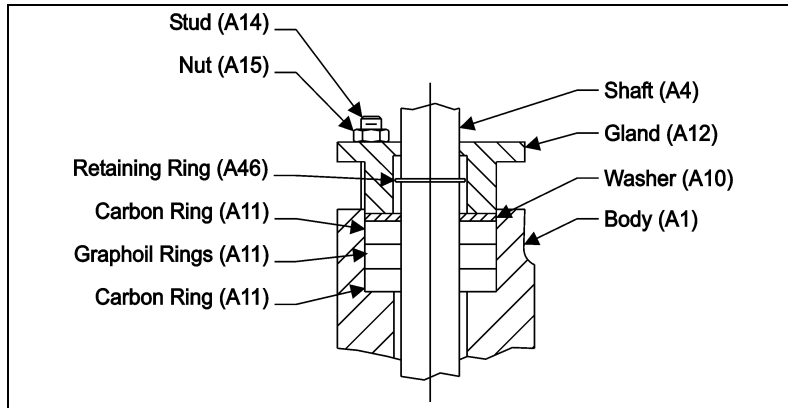

Figure 6 — Packing Option (G1)

- a. Place the packing in the body, one ring at a time, in the configuration shown in Figure 6 — do not lubricate.
- b. Place the packing washer (A10) into the packing chamber.
- c. Install the retaining ring (A46) into the groove in the shaft (A4).
- d. Replace the gland (A12) and the two gland nuts (A15).
- e. Tighten the nuts finger tight, plus ½ turn.
- f. Continue with step 10 on page 16.

Graphoil Packing Option (G2)

The new packing consists of three or more Graphoil rings (A11) between two anti-extrusion washers (A34).

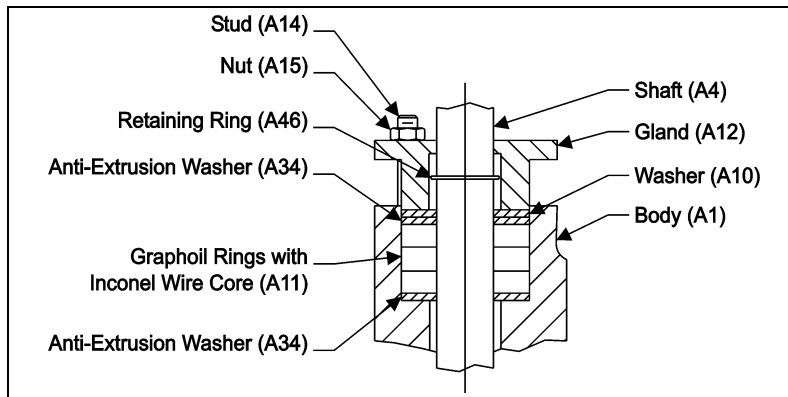

Figure 7 — Packing Option (G2)

- a. Lubricate the inside and outside diameters of each new packing ring with Krytox 240 AC lubricant.
- b. Place the new packing and anti-extrusion washers in the body, one ring at a time, in the configuration shown in Figure 7.
- c. Place the packing washer (A10) into the packing chamber.
- d. Install the retaining ring (A46) into the groove in the shaft (A4).

Replacing Packing (Continued)

- e. Replace the gland (A12) and the two gland nuts (A15). Tighten the nuts finger tight, plus ½ turn.
- f. Continue with step 10 on page 16.

Graphoil Live-Loaded Packing Option (G2L)

The new packing (A11) consists of three or more Graphoil rings between two anti-extrusion washers (A34). A quantity of new spring washers (A36) is required as shown in Table A (page 17) for Class 150 valves and in Table B (page 18) for Class 300 valves.

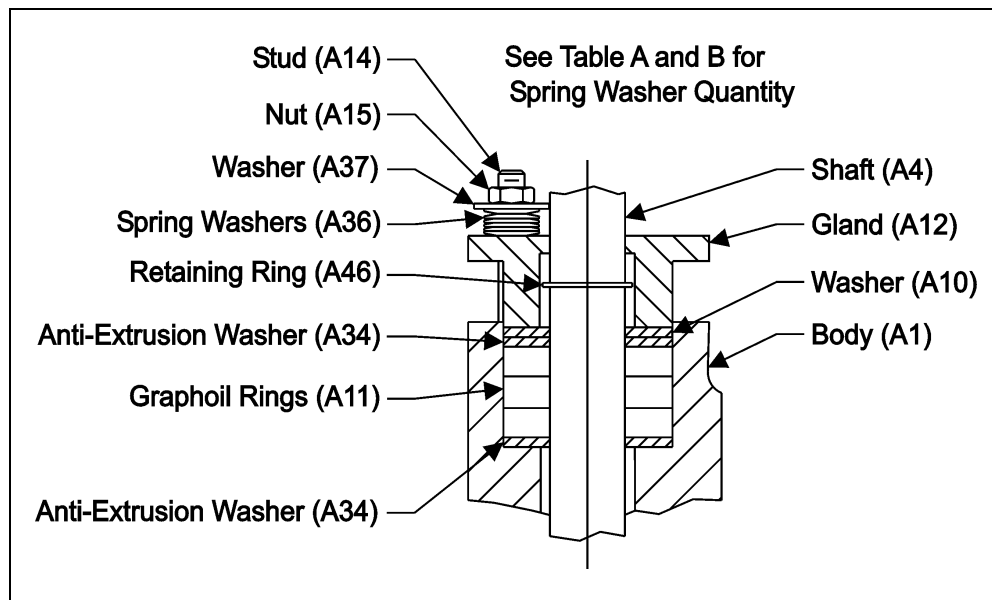

Figure 8 — Packing Option (G2L)

- a. Lubricate the following surfaces with Krytox 240 AC lubricant:
 - The inside and outside of each new packing ring
 - The threads of the two studs (A14)
 - The threads and contact faces of the two gland nuts (A15)
- b. Place the new packing (A11) and anti-extrusion washers (A34) in the body, one ring at a time, in the configuration shown in Figure 8.
- c. Place the packing washer (A10) into the packing chamber.
- d. Install the retaining ring (A46) into the groove in the shaft (A4).
- e. Replace the gland (A12), the new spring washers (A36), the two flat washers (A37) and the two gland nuts (A15).
- f. Arrange the spring washers in the configuration shown, with the top and bottom washers in series and the remaining washers in parallel.
- g. Tighten the nuts finger tight and torque the nuts evenly to the value in Table A (page 17) for Class 150 valves and in Table B (page 18) for Class 300 valves.
- h. Continue with step 10 on page 16.

Replacing Packing *(Continued)***Graphoil Dual-Seal Packing Option (G2D)**

The new primary packing (A11) consists of three or more Graphoil rings between two anti-extrusion washers (A34); the new secondary packing (A26) consists of two Graphoil rings between two anti-extrusion washers (A34).

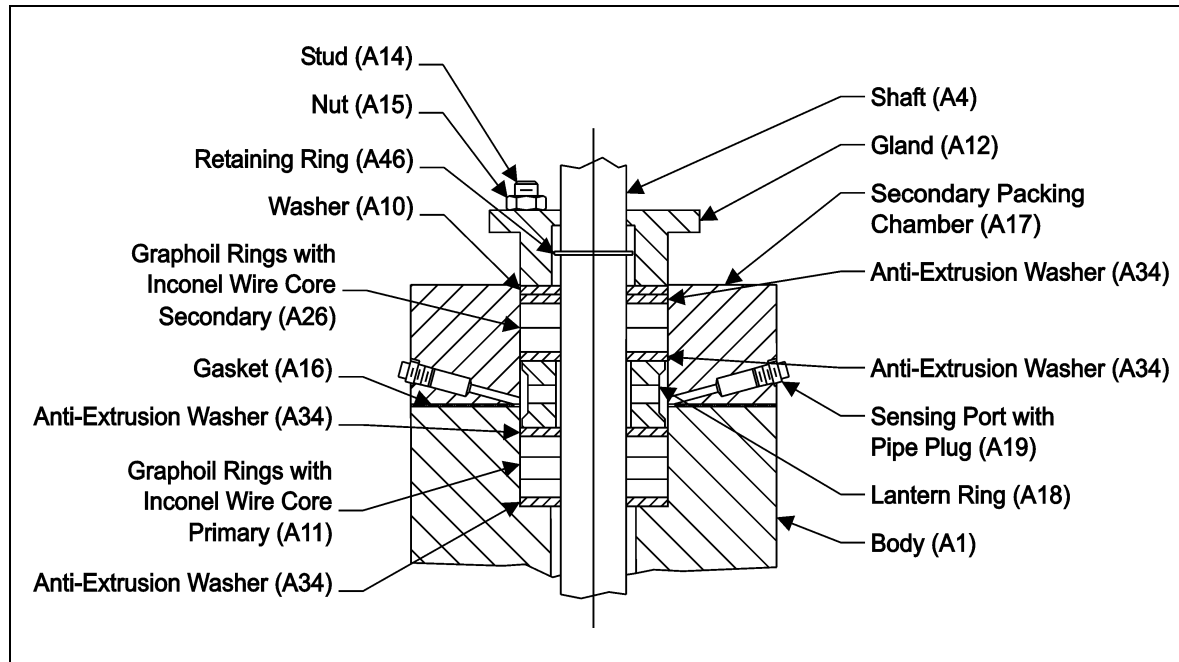

Figure 9 — Packing Option (G2D)

- a. Lubricate the inside and outside diameters of each new packing ring with Krytox 240 AC lubricant.
- b. Place the primary (lower) set of new packing (A11) and anti-extrusion washers (A34) in the body, one ring at a time, as shown in Figure 9.
- c. Remove the two gland studs (A14) from the secondary packing chamber (A17) and temporarily place the studs in the threaded holes in the body.
- d. Place the gland (A12) and nuts (A15) on the studs and turn the nuts evenly until the gland has moved about 25% of the distance from the bottom of the gland to the top of the body.
- e. Remove the nuts, the gland and the studs and replace the studs in the secondary packing chamber.
- f. Place the following parts in the configuration shown in Figure 9:
 - The new gasket (A16)
 - The secondary packing chamber (A17)
 - The lantern ring (A18), the two new packing rings (A26)
 - One ring at a time (lubricated)
 - Anti-extrusion washers (A34)
 - Packing washer (A10)
 - Retaining ring (A46)
 - The gland (A12) and the gland nuts (A15)—do not tighten the nuts.

Replacing Packing (Continued)

- g. Mount the actuator bracket and secondary packing chamber to the body with the same screws and tighten as shown in Table C (page 19). Tighten the gland nuts (A15) finger tight, plus ½ turn.
- h. Continue with step 10 on page 16.

Graphoil Dual-Seal Live-Loaded Packing Option (G2LD)

Components are the same as option G2D. In addition, a quantity of new spring washers (A36) is required as shown in Table A (page 17) for Class 150 valves and in Table B (page 18) for Class 300 valves.

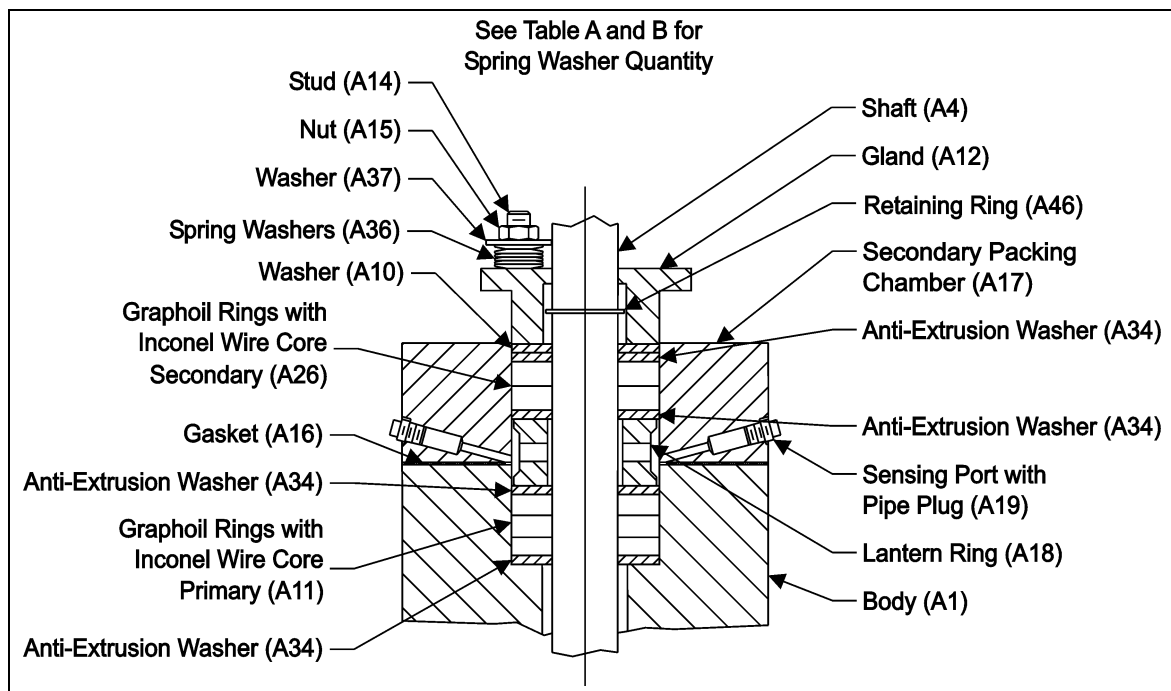

Figure 10 — Packing Option (G2DL)

- a. Follow steps “a” through “e” in G2D section.
- b. Place the following components in the configuration shown in Figure 10:
 - The new gasket (A16)
 - The secondary packing chamber (A17)
 - The lantern ring (A18), the two new packing rings (A26), (one ring at a time)
 - Anti-extrusion washers (A34)
 - Packing washer (A10)
 - Retaining ring (A46)
 - The gland (A12) and the gland nuts (A15) and the new spring washers (A36)
 - The two flat washers (A37) in the configuration shown in Figure 8 on page 13, with the top and bottom washers in series and the remaining washers in parallel—do not tighten the nuts.

DeZURIK

BHP High Performance Butterfly Valves

(S10, S2A, S3A, S5A, AAA, HCA, MLA, T2A & T5A Shafts)

Replacing Packing *(Continued)*

- c. Lubricate the threads of the two studs (A14) and the threads and contact faces of the two gland nuts (A15).
 - d. Mount the actuator bracket and the secondary packing chamber to the body with the same screws and tighten the screws as shown in Table C (page 19).
 - e. Tighten the gland nuts (A15) finger tight, plus ½ turn.
 - f. Torque the nuts evenly to the value in Table A (page 17) for Class 150 valves, or in Table B (page 18) for Class 300 valves.
 - g. Continue with step 10 on page 16.
10. If the valve has single packing, re-mount the actuator bracket on the valve and tighten the screws as shown in Table A (page 17).
 11. Mount the actuator on the valve—see actuator instructions.
 12. If the actuator is a powered actuator, reconnect power to the actuator.
 13. Actuate the valve. If necessary, adjust the position stops—see actuator instructions.
 14. Pressurize the valve.
 15. If the packing leaks, tighten the gland nuts evenly and slowly, just enough to stop the leak.
 16. If the valve has dual packing, remove the pipe plug from one of the sensing ports in the secondary packing chamber.
 - If leakage occurs through the sensing port on valves with the graphoil dual-seal packing option, tighten the gland nuts evenly and slowly, just enough to stop the leakage and replace the pipe plug.
 - If leakage occurs through the sensing port on valves with the PTFE dual-seal/mechanical spring packing option, repeat the steps in this section, starting with step 1, and replace the packing components located in the valve body, below the secondary packing chamber.

Torque Specification

Table A: Class 150 Valves—Gland Nut Torques and Spring Washer Quantities for Live-Loaded Packing

Valve Size		Gland Nut Torque		Spring Washers (17-7PH Stainless Steel)				
				Quantity Each Gland Stud	Dimensions (Ref) in [mm]			
in	mm	in lbs	Nm			Outside Diameter	Inside Diameter	Material Thickness
2	50	4±0.5	0.45±0.05	5	0.551 [14.00]	0.283 [7.19]	0.014 [0.35]	0.032 [0.81]
2.5	65	5±0.5	0.56±0.05					
3	75	6±0.5	0.67±0.05					
4	100	6±0.5	0.67±0.05	6				
5	125	11±0.5	1.2±0.05	8	0.551 [14.00]	0.283 [7.19]	0.014 [0.35]	0.032 [0.81]
6	150	16±1	1.8±0.11	5	0.709 [18.00]	0.323 [8.20]	0.020 [0.50]	0.043 [1.09]
8	200	19±1	2.1±0.11	6				
10	250	23±1	2.5±0.11	7				
12	300	43±2	4.8±0.22	4	0.787 [20.00]	0.402 [10.21]	0.035 [0.89]	0.057 [1.45]
14	350	43±2	4.8±0.22					
16	400	45±2	5±0.22					
18	450	59±2	6.6±0.22	6	0.984 [25.00]	0.480 [12.19]	0.028 [0.71]	0.063 [1.60]
20	500	70±2	7.9±0.22	5	0.984 [25.00]	0.480 [12.19]	0.035 [0.89]	0.063 [1.60]
24	600	105±2	11.8±0.22	6	1.100 [27.94]	0.559 [14.20]	0.032 [0.81]	0.075 [1.90]
30	750	156±3	17.6±0.33	6	1.100 [27.94]	0.559 [14.20]	0.039 [0.99]	0.071 [1.80]
36	900	185±3	20.9±0.33	4	1.100 [27.94]	0.559 [14.20]	0.049 [1.24]	0.083 [2.11]

DeZURIK

BHP High Performance Butterfly Valves

(S10, S2A, S3A, S5A, AAA, HCA, MLA, T2A & T5A Shafts)

Torque Specification *(Continued)*

Table B: Class 300 Valves—Gland Nut Torques and Spring Washer Quantities for Live-Loaded Packing

Valve Size		Gland Nut Torque		Spring Washers (17-7PH Stainless Steel)				
				Quantity Each Gland Stud	Dimensions (Ref) in [mm]			
in	mm	in lbs	Nm			Outside Diameter	Inside Diameter	Material Thickness
2	50	13±0.5	1.4±0.05	9	0.551 [14.00]	0.283 [7.19]	0.014 [0.35]	0.032 [0.81]
2.5	65	14±0.5	1.5 ±0.05	10				
3	75	16±1	1.8±0.11	6	0.551 [14.00]	0.283 [7.19]	0.020 [0.50]	0.035 [0.89]
4	100	28±1	3.1±0.11	8				
5	125	40±1	4.5±0.11	7	0.630 [16.00]	0.323 [8.20]	0.024 [0.61]	0.041 [1.04]
6	150	49±2	5.5±0.22	8				
8	200	59±2	6.6±0.22	4	0.630 [16.00]	0.323 [8.20]	0.035 [0.89]	0.049 [1.24]
10	250	110±3	12.4±0.33	8				
12	300	126±3	14.2±0.33			0.984 [25.00]	0.480 [12.19]	0.035 [0.89]
14	350	152±3	17.1±0.33	7				
16	400	163±3	18.4±0.33	7	1.240 [31.50]	0.480 [12.19]	0.039 [0.99]	0.083 [2.11]
18	450	181±3	20.4±0.33	8				
20	500	274±4	30.9±0.45	7	1.340 [34.04]	0.563 [14.30]	0.049 [1.24]	0.095 [2.41]
24	600	382±4	43.1±0.45	7				

Torque Specification (Continued)**Table C: Fastener Torques, Actuator Bracket-to-Valve**

Valve			Fastener			
Class	Size		Size (Ref)	Grade (Ref)	Torque	
	in	mm			ft lbs	Nm
150	2-4	50-100	1/4-20	8	13±1	18±1
	5-8	125-200	5/16-18		27±4	37±5
	10	250	3/8-16	5	41±5	56±10
	12-16	300-400	1/2-13		99±13	135±18
	18 and 20	450-500	5/8-11		200±20	272±27
	24-36	550-900	5/8-11		180±20	244±27
	42 and 48	1050-1200	3/4-10		330±40	447±54
300	2-3	50-150	1/4-20	8	13±1	18±1
	4-6	100-150	5/16-18		27±4	37±5
	8	200	3/8-16	5	41±5	56±10
	10 & 12	250 & 300	1/2-13		99±13	135±18
	14	350	5/8-11		200±20	272±27
	16-24	400-600	5/8-11		180±20	244±27
	30 & 36	750 & 900	3/4-10		330±40	447±54

Seat Replacement

Removing Valve From Pipeline



WARNING!

Pipeline pressure can cause personal injury or equipment damage. Relieve the pressure in the pipeline before removing flange bolts and flanges.

1. Relieve pressure in the pipeline and drain the pipeline.
 2. Close the valve.
-



WARNING!

Accidental operation of powered actuator can cause personal injury or equipment damage. Disconnect and lock out power to actuator before servicing.

3. If the actuator is powered, disconnect and lock out the power to the actuator.
4. Support the valve, remove the flange bolts and remove the valve from the pipeline.

Note: Lifting the valve incorrectly can damage it. Do not fasten lifting devices to the actuator or disc, or through the seat opening in the body. Lift the valve with slings fastened around the valve body, or attach them to bolts or rods run through holes for the pipeline flanges.

Replacing the Seat

1. Place the valve in a horizontal position, with the seat side up.
2. Refer to Figure 1 (page 6) for component identification.
3. Remove the seat retainer screws (A23), the seat retainer (A20) and all of the seat components.

Note: The seat retainer on valve sizes 14" (350mm) and larger has two tapped holes. Screws may be threaded into these holes to remove the seat retainer.

4. Clean the seat cavity in the body and the seat cavity in the seat retainer.
5. Close the valve.
6. Refer to the appropriate seat option:

- Resilient Seat Options (TT, TI, RT and RI)—see page 21
- Metal Seat Option (S2)—see page 22
- Fyre-Block™ Seat Options (RTS2, TTS2, TIS2, and RIS2)—see page 23

Seat Replacement *(Continued)***Resilient Seat Options (TT, TI, RT and RI)**

- a. Place the seat control ring (A22) in the groove in the new seat (A21) and center the seat on the closed disc
- b. On valve sizes 5–10" (125–250mm) only, center seat retainer gasket (A6) in position on the body.
- c. Apply a media compatible rust inhibitor to the threads of the seat retainer screws (A23). Mount the seat retainer (A20) to the body with the seat retainer screws and tighten the screws as shown in Table D (page 23).
- d. Continue with step 7 on page 24.

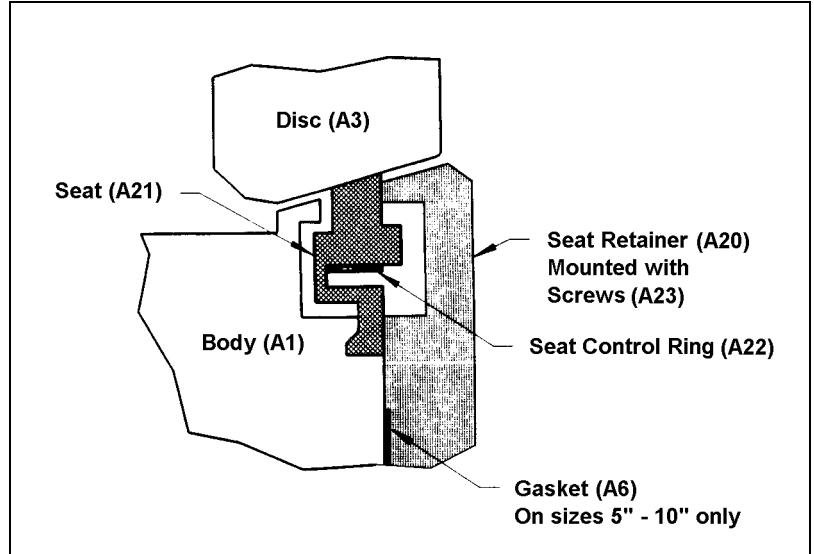
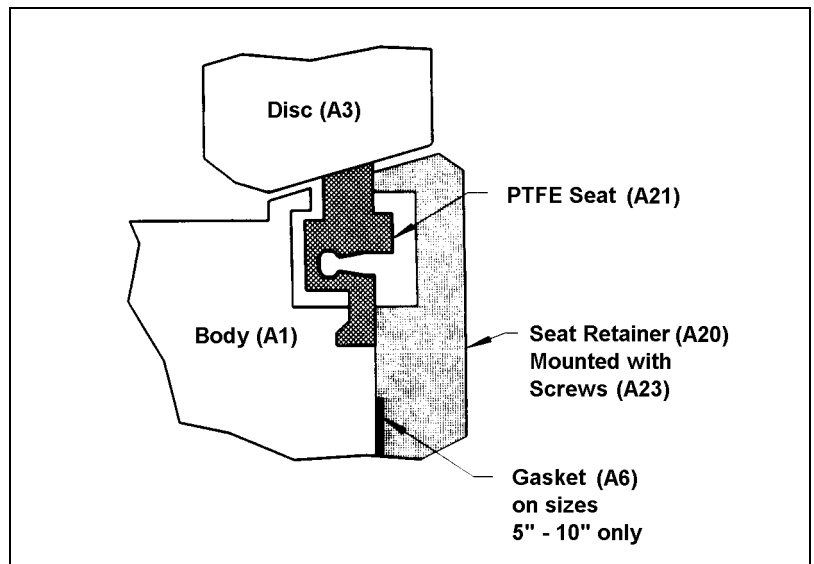
**Figure 11 — Resilient Seat Option****Figure 11 — Previous Version of Resilient Seat**

Seat Replacement (Continued)

Metal Seat Option (S2)

- a. If the actuator is connected to the valve shaft, loosen the connection so that the valve shaft can rotate.
- b. Loosen the packing gland nuts (A15).
- c. Place the seat support ring (A29) in the body.
- d. Center the gasket (A27) and the metal seat (A28) on the closed disc.
- e. Apply a media compatible rust inhibitor to the threads of the seat retainer screws (A23).
- f. With all components centered, mount the seat retainer (A20) to the body with the seat retainer screws. Tighten the screws as shown in Table D (page 23).
- g. If the valve-to-actuator connection was loosened in step a, re-tighten the connection.
- h. Adjust the packing gland nuts (A15) as described in the *Packing Adjustment* section. If the packing is live-loaded, tighten the nuts as shown in Table A (page 17) for Class 150 valves, or in Table B (page 18) for Class 300 valves.
- i. Continue with step 7 on page 24.

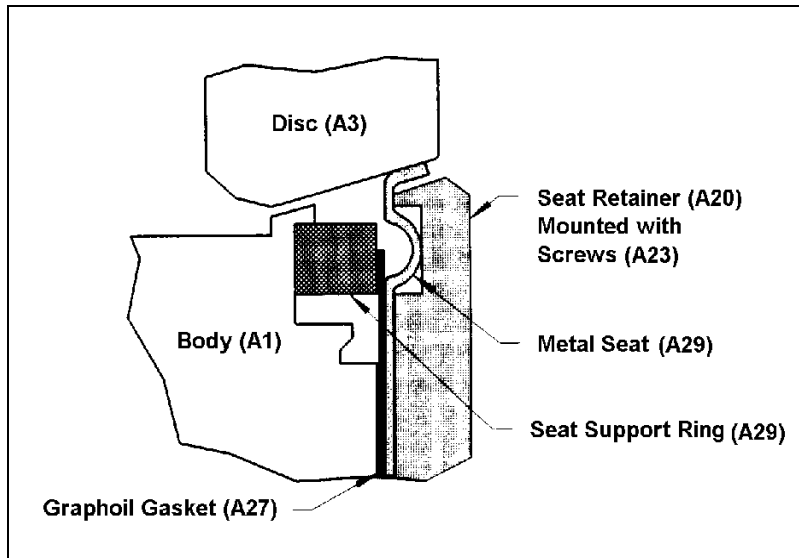

Figure 12 — Metal Seat Option (S2)

Seat Replacement (Continued)**Fyre-Block™ Seat Options (RTS2, TTS2, TIS2, and RIS2)**

- a. If the actuator is connected to the valve shaft, loosen the connection so that the valve shaft can rotate.
- b. Loosen the packing gland nuts (A15).
- c. Place the seat control ring (A22) in the groove in the new PTFE seat (A21).
- d. Center the PTFE seat (A21), the gasket (A27) and the metal seat (A28) on the closed disc.
- e. Apply a media compatible rust inhibitor to the threads of the seat retainer screws (A23).
- f. With all components centered, mount the seat retainer (A20) to the body with the seat retainer screws. Tighten the screws as shown in Table D.
- g. If the valve actuator connection was loosened in step a, tighten the connection.
- h. Adjust the packing gland nuts (A15) as described in the *Packing Adjustment* section.
- i. Continue with step 7 on page 24.

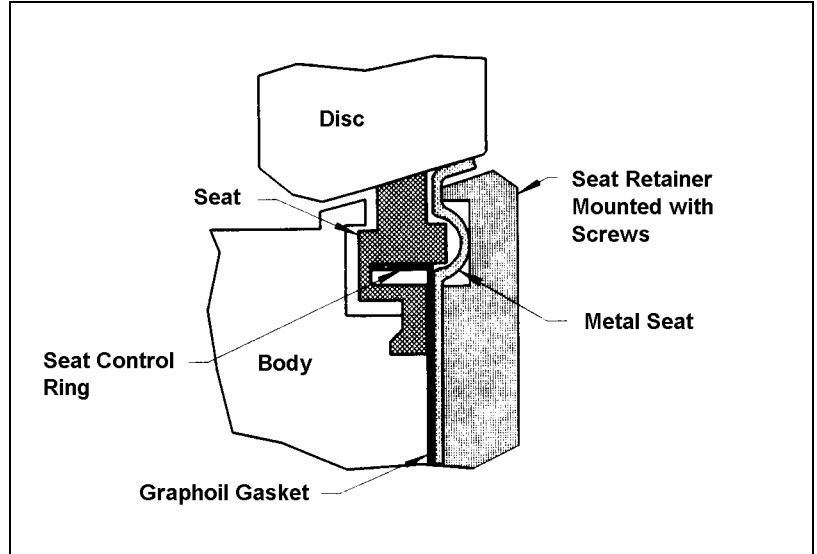

Figure 13 — Seat Options
(RTS2, TTS2, TIS2, and RIS2)

Table D: Seat Retainer Screw Torques

Screw Size	Torque	
	ft lbs	Nm
8-32	1.5 ± 0.5	2.03 ± 0.69
10-24	2.5 ± 0.5	3.39 ± 0.69
1/4-20	5.5 ± 1.5	7.46 ± 2.03
5/16-18	12.0 ± 3.0	16.27 ± 4.07
3/8-16	21.5 ± 5.5	29.15 ± 7.46

Valve Disassembly

Refer to Figure 1 (page 6) for component identification.



WARNING!

Pipeline pressure can cause personal injury or equipment damage. Relieve the pressure in the pipeline before removing flange bolts and flanges.

1. Relieve the pressure in the pipeline, drain the pipeline and close the valve.
-



WARNING!

Accidental operation of powered actuator can cause personal injury or equipment damage. Disconnect and lock out power to actuator before servicing.

2. If the actuator is powered, disconnect and lock out the power to the actuator.
3. Support the valve, remove the flange bolts and remove the valve from the pipeline.
Note: Lifting the valve incorrectly can damage it. Do not fasten lifting devices to the actuator or disc, or through the seat opening in the body. Lift the valve with slings fastened around the valve body, or attach them to bolts or rods run through holes for the pipeline flanges.
4. Remove the actuator and the actuator bracket from the valve.
5. Remove the two gland nuts (A15) and remove the gland (A12).
Note: Live-loaded packing options include a flat washer (A37) and several spring washers (A36) under each gland nut. When required, the gland consists of a two-piece gland (A12) and gland plate (A39).
6. Remove the retaining ring (A46) from the shaft (A4).
7. Remove the packing washer (A10) and all of the packing (A11).
8. If the valve has the dual-packing option, remove the secondary packing chamber (A17) and the gasket (A16) and remove all of the secondary packing—do not re-use removed packing.
9. Remove all packing fragments, dirt and other contaminants from all packing sealing surfaces.
10. Remove the seat retainer screws (A23), the seat retainer (A20) and all of the seat components.
Note: The seat retainer on valve sizes 14" and larger has two tapped holes. Screws may be threaded into these holes to remove the seat retainer.
11. On Class 150 valve sizes 2–18" (50–450mm) and Class 300 valve sizes 2–16" (50–400mm), remove the pipe plug (A9) from the bottom of the body.

Valve Disassembly *(Continued)*

12. On larger sizes, remove the cover screws (A33), lockwashers (A32), cover (A31) and seal (A30) from the bottom of the body.
13. Remove the disc pin—see Figure 14 (page 28):
 - On valve sizes 2–12" (50–400mm), remove the disc pin set screw (A24) and drive the disc pin (A5) from the disc with a small punch. Do not damage the shaft with the punch.
 - On larger sizes, remove the two disc pins (A5) with a large screw driver.
14. Place the valve in a horizontal position with the seat side down.
15. While supporting the disc (A3), carefully pull the shaft (A4) from the body and remove the disc.

Bearing Replacement***Bearing Removal***

1. Remove the upper bearing (A2) from the body through the packing chamber.
2. Remove the lower bearing (A2) from the body through the pipe plug/cover access located on the bottom of the valve.

Bearing Replacement

1. Apply a light coat of media compatible grease to the inside diameter of the bearings (A2).
 - a. If bearing has a fabric liner, the bearing does not require lubrication.
2. Insert the new upper bearing (A2) through the packing chamber and into position in the body.
3. Insert the lower bearing (A2) through the pipe plug/cover access located on the bottom of the valve and into position in the body.

Note: For FT bearings, to increase bearing life, position the split in the bearing towards the side of the body rather than parallel with the pipeline.

DeZURIK

BHP High Performance Butterfly Valves

(S10, S2A, S3A, S5A, AAA, HCA, MLA, T2A & T5A Shafts)

Valve Reassembly

Clean and inspect all parts, and replace worn parts before reassembly. Refer to Figure 1 for component identification. The valve requires lubrication only when it is being assembled. Refer to the Actuator Instructions for lubrication requirements for the actuator.

1. Apply a light coat of media compatible grease around the shaft hole on each end of the disc (area that contacts the disc locating surfaces in the body).
2. With the valve horizontal and the seat side down, insert the disc (A3) into body (A1) and align the shaft hole in the disc with the bearing in the body.
3. Insert the bottom end of the shaft (the end without an actuator connection) into the top of the body and push the shaft into position.
4. Rotate the shaft so that the line on the top end of the shaft is towards and parallel with the flat (or concave) side of the disc.

On valve sizes 2–12" (50–400mm)

- a. Slide the shaft so that the top end of the shaft protrudes from the body to the dimension in Table E.

Table E: Dimension from Top-of-Body to Top-of-Shaft

Valve Size		Class 150		Class 300	
in	mm	in	mm	in	mm
2–3	25–75	3.75	95	3.75	95
4	100	3.75	95	4.25	105
5 & 6	125&150	4.25	108	4.25	108
8	200	4.25	108	4.63	118
10	250	4.63	118	4.75	120
12	300	4.75	120	4.75	120

- b. Place the disc pin (A5) in the hole in the disc (A3) as shown in Figure 14 on page 28 and tap the end of the pin lightly to seat the pin against the flat on the shaft (A4). A new set screw (A24) is required.

- c. Apply Loctite 271 to the set screw threads.

- d. Turn the set screw into the end of the pin and tighten the set screw as shown in Table F (page 27).

- e. As shown in Figure 14 (page 28), stake the end of the set screw threads once with a pointed punch to secure the set screw in position.

On valve sizes 14" (350mm) and larger,

- a. Slide the shaft so that the disc pin slots in the shaft are aligned with the disc pin holes in the disc.
- b. Apply a media compatible rust inhibitor to the threads of the disc pins (A5).
- c. Use two new pins and turn the pins into the threaded holes in the disc (A3) and against the slots in the shaft (A4) as shown in Figure 14 (page 28).
- d. Adjust the pins so that both pins protrude the same distance above the disc surface and tighten the pins as shown in Table F (page 27).
- e. As shown in Figure 14 (page 28), stake the screw threads on each disc pin once with a pointed punch to secure the pins in position.

5. Replace the seat and the seat retainer as described in steps 4, 5 and 6 in the *Seat Replacement* section on page 20.

Valve Reassembly (Continued)

6. Replace the packing, the packing gland and the gland adjustment nuts as shown in steps 7 and 8 of the *Replacing Packing* section on page 7.
7. On Class 150 valve sizes 2–18" (50–450mm) and Class 300 valve sizes 2–16" (50–400mm), replace and tighten the pipe plug (A9) in the bottom of the body.

Note: With metal seat option, seal the threads of the pipe plug with Sepco SG630805AN-25 UCAR Graphoil Tape; with other seats, use PTFE tape. Wind the tape three turns counterclockwise, as viewed from the threaded end and spiral the tape approximately one thread for each turn.

8. On larger sizes:
 - a. Mount the cover (A31) and seal (A30) to the bottom of the body with the cover screws (A33).
 - b. Lubricate the threads of the screw with a rust inhibitor.
 - c. Tighten the screws as follows: 1/2-13 screws to 38±5 ft lbs. (52±6 Nm), 5/8-11 screws to 77±10 ft lbs. (104±14 Nm) and 3/4-10 screws to 140±18 ft lbs. (190±24 Nm).
9. Mount the actuator bracket on the valve and tighten the screws as shown in Table A (page 17).
10. Re-mount the actuator on the valve (see actuator instructions).
11. Actuate the valve. If necessary, adjust the actuator position stops.
12. Install the valve in the pipeline as described in the *Installing Valve* section.
13. If the actuator is a powered actuator, reconnect the power to the actuator.
14. Pressurize the valve.
15. If packing leaks, tighten the gland nuts evenly and slowly – just enough to stop the leak.

Table F: Disc Pin Torques

Fastener Type	Fastener Size	Torque	
		ft lbs.	Nm
2–12" (50-300mm) Disc Pin Set Screw (A24)	1/4-20	3±1/2	4±1
	5/16-18	7±1	10±1
	3/8-16	13±2	18±2
	1/2-13	30±4	40±5
	5/8-11	63±8	85±10
14–48" (350-1200mm) Disc Pin (A5)	3/4-10	115±15	160±20
	7/8-9	180±23	245±30
	1-8	270±35	370±50
	1 1/8-7	380±50	520±70
	1 1/4-7	540±70	730±95
	1 3/4-5	1600±200	2200±300
	2-8	2100±300	2900±400

Valve Reassembly (Continued)

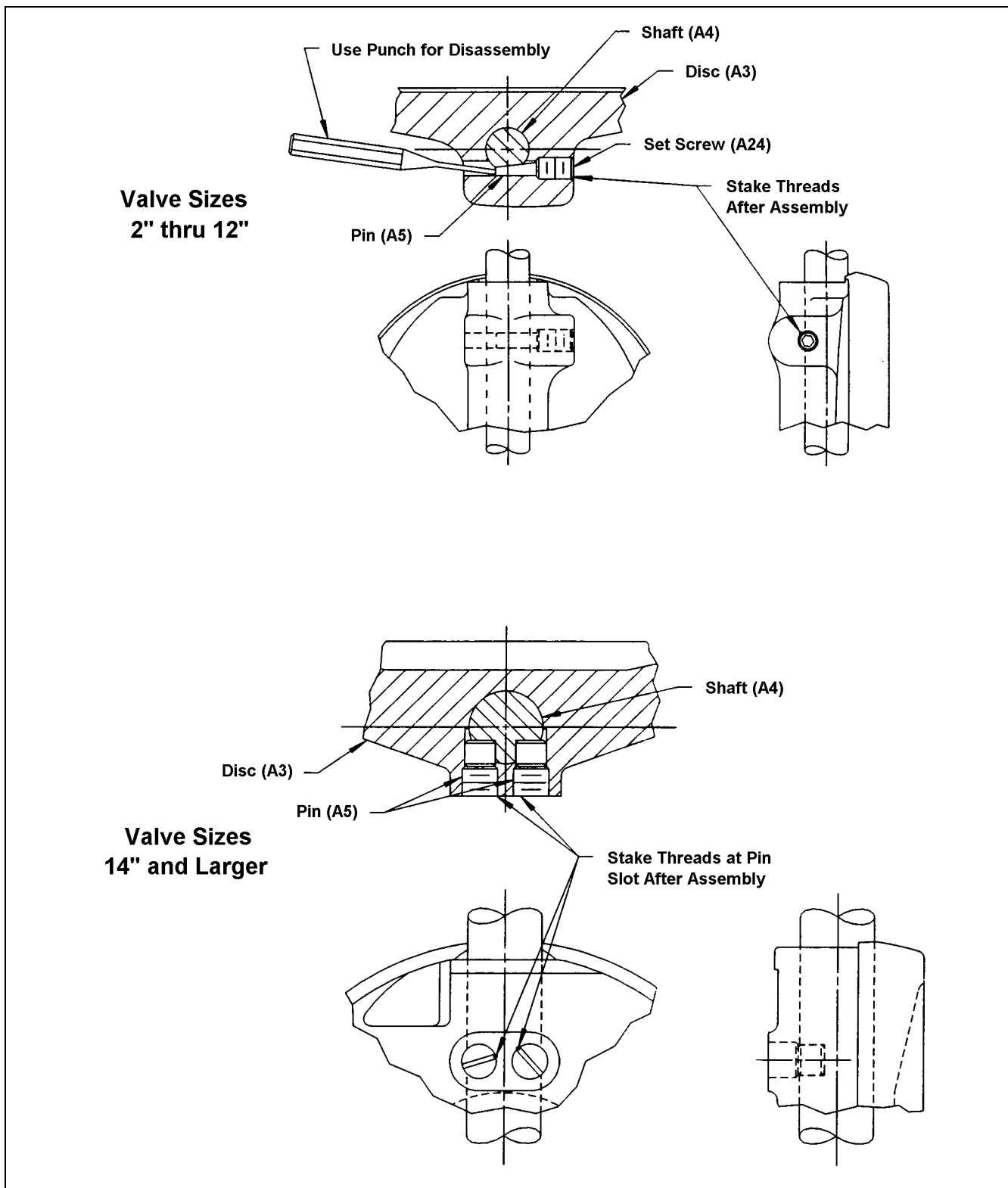

Figure 14 – Disc Pin Assembly

Troubleshooting

Condition	Possible Cause	Corrective Action
Packing Leaks	Packing is loose.	Adjust packing.
	Packing is worn.	Replace packing.
Valve leaks when closed.	Closed position stop is set incorrectly.	Adjust closed stop.
	Seat is worn or damaged.	Replace seat.
	Sealing edge of disc is worn or damaged.	Replace disc.
Valve body leaks from seat retainer area.	Pipeline flange bolting is loose.	Tighten pipeline flange bolts.
	Pipeline flanges are misaligned.	Align pipeline flanges.
	Pipeline flange gasket or seat retainer gasket is worn.	Replace gasket(s).
Valve does not fully close.	Object is wedged between disc and seat.	Open valve and allow flushing action to remove object.
	Closed position stop is not adjusted correctly.	Adjust closed stop.
	Disc-to-shaft connection has failed.	Replace disc pins and/or shaft.
Valve does not fully open.	Open position stop is not adjusted correctly.	Adjust open stop.
	Disc-to-shaft connection has failed.	Replace disc pins and/or shaft.
Opening or closing torque is excessive.	Bearings, shaft, disc and/or seat are dirty or worn.	Clean or replace dirty or worn components.
	Shaft is bent.	Replace shaft.
Seat leakage and/or damage to seat has occurred.	Media is abrasive.	Replace existing seat with a seat that is suitable for abrasive media.
Valve components are eroding.		Replace valve with materials suitable for abrasive media.
Valve leakage and/or damage to valve has occurred.	Valve encountered higher than rated pressure.	Reduce media pressure.
Seat leakage and/or damage to seat has occurred.	Valve encountered higher than rated temperature.	Reduce media temperature.
		Replace existing seat with a seat suitable for the required temperature.
Valve components are corroding.	Media is corrosive and incompatible with valve material.	Replace existing valve with a valve constructed of material compatible with the media.

Guarantee

Products, auxiliaries and parts thereof of DeZURIK, Inc. manufacture are warranted to the original purchaser for a period of twenty-four (24) months from date of shipment from factory, against defective workmanship and material, but only if properly installed, operated and serviced in accordance with DeZURIK, Inc. recommendations. Repair or replacement, at our option, for items of DeZURIK, Inc. manufacture will be made free of charge, (FOB) our facility with removal, transportation and installation at your cost, if proved to be defective within such time, and this is your sole remedy with respect to such products. Equipment or parts manufactured by others but furnished by DeZURIK, Inc. will be repaired or replaced, but only to the extent provided in and honored by the original manufacturers warranty to DeZURIK, Inc., in each case subject to the limitations contained therein. No claim for transportation, labor or special or consequential damages or any other loss, cost or damage shall be allowed. You shall be solely responsible for determining suitability for use and in no event shall DeZURIK, Inc. be liable in this respect. DeZURIK, Inc. does not guarantee resistance to corrosion, erosion, abrasion or other sources of failure, nor does DeZURIK, Inc. guarantee a minimum length of service. Your failure to give written notice to us of any alleged defect under this warranty within twenty (20) days of its discovery, or attempts by someone other than DeZURIK, Inc. or its authorized representatives to remedy the alleged defects therein, or failure to return product or parts for repair or replacement as herein provided, or failure to install and operate said products and parts according to instructions furnished by DeZURIK, Inc., or misuse, modification, abuse or alteration of such product, accident, fire, flood or other Act of God, or failure to pay entire contract price when due shall be a waiver by you of all rights under this warranty.

The foregoing guarantee shall be null and void if, after shipment from our factory, the item is modified in any way or a component of another manufacturer, such as but not limited to, an actuator is attached to the item by anyone other than DeZURIK, Inc. Factory Service personnel. All orders accepted shall be deemed accepted subject to this limited warranty, which shall be exclusive of any other or previous Warranty, and this shall be the only effective guarantee or warranty binding on DeZURIK, Inc., despite anything to the contrary contained in the purchase order or represented by any agent or employee of DeZURIK, Inc., in writing or otherwise, notwithstanding, including but not limited to implied warranties.

THE FOREGOING REPAIR AND REPLACEMENT OBLIGATIONS ARE IN LIEU OF ALL OTHER WARRANTIES, OBLIGATIONS AND LIABILITIES, INCLUDING ALL WARRANTIES OF FITNESS FOR A PARTICULAR PURPOSE OR OF MERCHANTABILITY OR OTHERWISE, EXPRESSED OR IMPLIED IN FACT OR BY LAW, AND STATE DEZURIK, INC.'S ENTIRE AND EXCLUSIVE LIABILITY AND YOUR EXCLUSIVE REMEDY FOR ANY CLAIM IN CONNECTION WITH THE SALE AND FURNISHING OF SERVICES, GOODS OR PARTS, THEIR DESIGN, SUITABILITY FOR USE, INSTALLATION OR OPERATIONS.

Limitation of liability

LIMITATION OF LIABILITY: IN NO EVENT SHALL DEZURIK, INC. BE LIABLE FOR ANY DIRECT, INDIRECT, SPECIAL OR CONSEQUENTIAL DAMAGES WHATSOEVER, AND DEZURIK, INC.'S LIABILITY, UNDER NO CIRCUMSTANCES, WILL EXCEED THE CONTRACT PRICE FOR THE GOODS AND/OR SERVICES FOR WHICH LIABILITY IS CLAIMED. ANY ACTION BY YOU FOR BREACH OF CONTRACT MUST BE COMMENCED WITHIN 12 MONTHS AFTER THE DATE OF SALE.

Sales and Service

For information about our worldwide locations, approvals, certifications and local representative:

Web site: www.dezurik.com E-Mail: info@dezurik.com



250 Riverside Ave. N., Sartell, MN 56377 • Phone: 320-259-2000 • Fax: 320-259-2227

DeZURIK, Inc. reserves the right to incorporate our latest design and material changes without notice or obligation. Design features, materials of construction and dimensional data, as described in this manual, are provided for your information only and should not be relied upon unless confirmed in writing by DeZURIK, Inc. Certified drawings are available upon request.